

AN INCLUSIVE APPROACH FOR **SCHOOL SANITATION & HYGIENE EDUCATION**

Strategy, Norms & Designs



AN INCLUSIVE APPROACH FOR
**SCHOOL SANITATION
& HYGIENE EDUCATION**

Technical Note Series





सत्यमेव जयते

शान्ता शीला नायर
SANTHA SHEELA NAIR



सचिव
भारत सरकार
ग्रामीण विकास मंत्रालय
पेय जल आपूर्ति विभाग
Secretary
Government of India
Ministry of Rural Development
Department of Drinking Water Supply
247, 'A' Wing, Nirman Bhawan, New Delhi-110011
Tel.: 23061207, 23061245 Fax : 23062715
E-mail : secydw@nic.in

Foreword

The Department of Drinking Water Supply has been continuously updating "technical notes" on Rural Water Supply and Sanitation design depending on local conditions and needs. The Department has been particularly sensitive to School Sanitation requirements which have evolved in response to felt needs.

The latest in this series seeks to combine gender sensitivity with actual "toilet" use patterns, and local conditions particularly water/soil properties and orientation suitable for least cost/most effective maintenance systems. The emphasis is to promote toilet system which provide adequate urinals in all schools are constructed in "safe" sites within the School premises.

The School Sanitation Programme is at a "tipping point", and at this stage, it is important to reinforce the quality of interventions. We sincerely hope that this technical document will contribute towards improvement of the quality of water and sanitation facilities in schools in the country.

New Delhi
28th July 2008

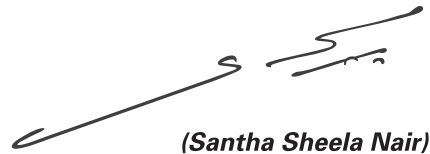
(Santha Sheela Nair)
Secretary to the Government of India

Preface

School Sanitation programme is an important component of the Total Sanitation Campaign (TSC) which aims at providing sanitation facilities for schools and thereby at changing the behaviour of children at a young age. It has gathered momentum in India in the last few years, and the country has made significant progress in terms of providing a toilet and urinal in every school. Functional sanitation and water facilities are now recognised as an integral part of the “quality package” in schools. The Total Sanitation Campaign (TSC) and the Sarva Shiksha Abhiyan (SSA) - the national umbrella programme for school education, are increasingly focussing on improving school environment and influencing hygiene behaviour of students.

The experience from the field with implementation of School Sanitation programme necessitated review of the existing designs of school toilets and urinals to make them more user and maintenance-friendly, inclusive and gender sensitive. Various rounds of consultations took place between the representatives from Government of India (Departments of Elementary Education and Drinking Water Supply), UNICEF’s education and WES sections, and technical experts resulting in a consensus on the norms that ought to guide the development of new designs, and the features of the document in which the designs would be presented, keeping in mind the final users. Consulting architects then worked on the document in close consultation with officials of DDWS and UNICEF.

This document has three parts: the first part discusses the features of the SSHE programme in the national context; the second part describes in detail the key principles which must guide construction of sanitation and drinking water facilities in schools and provides a tool for making decisions; the third part provides detailed engineering drawings (plan, layout and section drawings) and estimates for 16 different basic core designs.

This technical note is intended primarily for programme implementers to help them understand the critical need for proper school water and sanitation facilities and to sensitise them to the guiding principles that should be followed while planning for these facilities. Gender, expandability, inclusiveness, strength of students and space availability are some of the key design parameters used. The scope of this document has been made as comprehensive as possible by including discussion on several aspects of school environment such as solid and liquid waste management, rain water harvesting and availability of running water inside the sanitation complexes.

This is the result of excellent team work and synergy of contributions from different sectors and institutions. However we wish to acknowledge in particular the contribution of our colleagues from UNICEF, Department of Drinking Water Supply, Department of Elementary Education, and VINYAS in developing the norms and design options for this document.

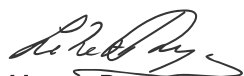

Lizette Burgers
Chief-WES, Unicef Delhi



T. M. Vijay Bhaskar
Joint Secretary (Sanitation)
Department of Drinking Water Supply

Table of Contents

PART I	Basic Concepts.....	1
	Introduction	2
	Section 1 Initiatives on SSHE.....	4
	Section 2 Elements of SSHE	7
	Section 3 Key lessons from programme implementation.....	12
PART II	Norms and Guiding Principles	15
	Section 1 Physical infrastructure under SSHE	17
	Section 2 Norms for basic water and sanitation facilities in schools	19
	Section 3 Guiding Principles of Designing of School Toilets Blocks	22
	Section 4 Key Data Required to Design Toilet Blocks	26
	Section 5 Other Important Interventions for maintaining Clean Environment in schools	54
PART III	Preparatory Planning, Designs and Estimates	63
	Introduction	64
	Section 1 Preparatory planning for sanitation facilities in school	65
	Section 2 Understanding the designs	67
	Section 3 Design Selection Tool	70
	Section 4 Designs	74
	Section 5 Good Designs from States.....	170

Abbreviations and Acronyms

ARWSP	Accelerated Rural Water Supply Programme
ANM	Auxiliary Nursing Midwife
BCD	Basic Core Design
BDO	Block Development Officer
BRC	Block Resource Centre
CRC	Cluster Resource Centre
CWSN	Children with Special Needs
DDWS	Department of Drinking Water Supply
DEEL	Department of Elementary Education and Literacy
DRDA	District Rural Development Authority
ECD	Expandable Core Design
FLHP	Force Lift Hand Pump
GoI	Government of India
ICMR	Indian Council of Medical Research
IEC	Information, Education and Communication
IMR	Infant Mortality Rate
KGBV	Kasturba Gandhi Balika Vidyalaya
MDM	Mid Day Meal
MoHFW	Ministry of Health and Family Welfare
MoHRD	Ministry of Human Resource Development
NBC	National Building Code
NCERT	National Council for Education, Research and Training
NCF	National Curriculum Framework
NFHS	National Family Health Survey
NGP	Nirmal Gram Puraskar
O & M	Operation and Maintenance
PHC	Primary Health Centre
PHED	Public Health Engineering Department
PRI	Panchayati Raj Institution
PTA	Parent Teacher Association
RDD	Rural Development Department
RGNDWM	Rajiv Gandhi National Drinking Water Mission
RSM	Rural Sanitary Mart
RWH	Rain Water Harvesting
SSA	Sarva Shiksha Abhiyan
SSHE	School Sanitation and Hygiene Education
SMC	School Management Committee
SWSM	State Water and Sanitation Mission
TSC	Total Sanitation Campaign
UNICEF	United Nations Children's Fund
VEC	Village Education Committee
WC	Water Closet



PART I

Basic Concepts

Introduction

Programme rationale

Schools, after the family, have a vital role to play for the cognitive and creative development of children. School is a socializing institution and stimulates learning environment and positive changes. They are equally important places to address the health and hygiene issues of children, provided necessary infrastructure is available. Improved health and quality learning are not possible in schools as long as basic hygiene is lacking or sanitary facilities and water supply are missing. And if children do not have the basic knowledge, attitude and habit of good hygiene or cannot practice them, their education is neither complete nor effective. Even worse, an unsafe school environment may damage their health especially in the case of girl children who are more vulnerable to malnutrition often leading to low enrolment and high drop out rates.

The provision of safe water and sanitation facilities in schools is a first step towards a healthy physical learning environment, benefiting both learning and health. However, the mere provision of facilities does not necessarily make them sustainable or produce the desired impact. It is the use of safe water and sanitary toilets and the related appropriate hygiene behaviour of people that provide health benefits. In schools, hygiene education aims to promote those practices that would help to prevent water and sanitation-related diseases as well as encourage healthy behaviour in future generations of adults.

School Sanitation and Hygiene Education, widely known as SSHE, is a comprehensive programme to ensure child-friendly water supply, toilet and hand washing facilities in schools and promote behavioural change by imparting hygiene education. SSHE not only ensures the child's right to have a healthy and clean environment but also leads to effective learning and increased enrolment of girls in particular, and reduces diseases and worm infestation. At present, SSHE is an important component of the Total Sanitation Campaign (TSC) and has been given special thrust by following the proven route of the teacher-children-family-community where the child is a change agent playing an effective role on a sustained basis to spread the message of improved

sanitary and healthy practices. TSC has provisions for toilet facilities and hygiene education in all Government Rural Schools. *School sanitation is also a non-negotiable component for Panchayats to be eligible for the Nirmal Gram Puraskar.*

Our Schools – rural context

India has one of the largest numbers of school-going children, especially in rural areas. There are about 7.6 lakh rural schools, both primary and upper primary with over 8 crore school-going children¹. As per the NFHS 3 - 2006, about 81 percent of the children in the primary age group of 6-10 are attending schools in rural areas. There has been an increase in the number of water and sanitation facilities in schools across the country, but these often face the following drawbacks:

- Insufficient or unsafe water supply and hand washing facilities;
- Children following poor hygiene and hand washing practices;
- Insufficient hygiene education for children;
- Toilets are not adapted to the needs of the children, in particular adolescent girls and the disabled;
- Lack of adequate solid/liquid waste disposal arrangements in schools;
- Unhealthy and dirty class rooms and school compounds;
- Lack of institutional arrangements for operation and maintenance of existing facilities and thus poor maintenance.

- On an average, 30 million people in rural areas suffer from sanitation related diseases.
- Five of the 10 top killer diseases of children aged 1-4 in rural areas are related to water and sanitation (Source: Central Bureau of Health Intelligence-MoHFW).
- About 3 to 4 lakh children die of diarrhoea annually, almost - 1000 every day.
- Typhoid, dysentery, gastroenteritis, jaundice and malaria claim the lives of over a fifth of children aged 1-14 in rural areas.
- India still has a high child mortality rate of 74 (NFHS-3) though improved over NFHS-2 which was as high as 95.
- High drop out rate, particularly among girls. Only 34 percent of the girls and 49 percent of the boys complete school education (Source: NFHS-3).

Under these conditions, schools and the community environment tend to become unsafe places where diseases are transmitted. For example, one of the major problems faced by school-going children is infections caused by a variety of pathogen and parasites, primarily from contaminated water or due to poor sanitation. Parasites consume nutrients from the infected children causing or aggravating malnutrition and retarding their physical development. Repeated diarrhoea and respiratory infections often compound the already poor health of children resulting in frequent absenteeism from school and affect learning achievements. The parasites also destroy tissues and organs on which they live causing pain and various longer-term health problems. Water and sanitation-related diseases that affect children include diarrhoea, dysentery, hepatitis, polio, trachoma and scabies. All of these compromise their attendance and performance at school and, not uncommonly, may also result in death. This is further aggravated by inadequate water and sanitation coverage in our country. According to NFHS-3, about 74 percent of rural households lack basic toilet facilities compared to 17 percent of urban households. Similarly, only 34.2 percent households in rural areas have drainage facilities for waste water disposal.

Some Facts on School Water and Sanitation

- There are 7.66 lakh primary and upper primary rural schools, of which 76.9 percent have water supply facility, 35.5 percent have urinals and 29.5 percent have lavatory facilities.
- Of the 7.55 lakh schools which have girl students as well, only 35 percent have separate urinals and 28.9 percent have lavatory facilities for girls.

(Source: 7th National Education Survey)

Graph 1:1. Water & Sanitation facilities in schools

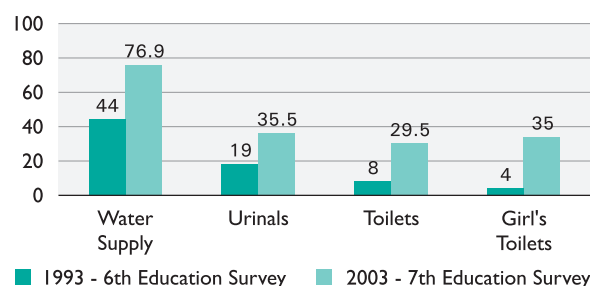

¹ 7th National Education Survey, MoHRD-GOI

Section 1

Initiatives on SSHE

Water supply, sanitation and hygiene education are important concerns in India and find prominent place in various programmes of Government of India. A majority of these programmes are implemented by the Department of Drinking Water Supply of the Ministry of Rural Development, and the Department of Elementary Education and Literacy under the Ministry of Human Resource Development.

Functional water supply is a crucial component of SSHE programming and the primary responsibility of providing drinking water facilities in schools rests with State Governments. The efforts of State Governments are supplemented by Government of India with financial assistance under the centrally-sponsored scheme of Accelerated Rural Water Supply Programme (ARWSP), launched in 1973. The broader objective of the programme is to ensure coverage of all rural habitations and, in particular, to reach the un-reached with access to safe drinking water and sustainable systems and sources. Schools are the key component of the programme and its funds can be mobilized to meet the requirement of drinking water supply. There are many technological options available for regular supply of water, for instance the force lift pump, piped water supply, etc. for which funds can be channelized. The schools can also join hands in the efforts to integrate water conservation through rainwater harvesting schemes with existing drinking water supply schemes for effective, safe and sustainable water supply.

Sarva Shiksha Abhiyan (SSA) is the Government of India's flagship programme for achievement of universalization of elementary education in a time-bound manner as mandated by 86th Amendment to the Constitution of India, making free and compulsory education for children of the age group 6-14 years, a Fundamental Right. SSA is being implemented in partnership with State Governments to cover the entire country and address the needs of 192 million children in 1.1 million habitations. SSA is an effort to universalize elementary education through community-ownership of the school system. It is a response to the demand for quality basic education all over the country. The SSA

Features of Sarva Shiksha Abhiyan (SSA)

- To open new schools in those habitations which do not have schooling facilities and strengthen existing school infrastructure through provision of additional classrooms, toilets, drinking water, maintenance grants and school improvement grants.
- Existing schools with inadequate teacher strength are provided with additional teachers.
- Capacity of existing teachers is strengthened by extensive training grants for developing teaching-learning materials and academic support structure at a cluster, block and district level.
- Provide quality elementary education including life skills.
- Provide computer education to bridge the digital divide.

programme is also an attempt to provide an opportunity for improving life skills of all children through provision of community-owned quality education in a mission

SSHE goals under TSC

- To provide water and sanitation facilities in all rural schools by March 2008.
- All co-education schools to have separate toilet facility for girls.
- Functional facilities in all schools and adequate O&M arrangements.

mode. SSA has a special focus on education of girls and children with special needs.

TSC and SSA are working in convergence to provide water and sanitation facilities to schools.

At all new schools being constructed under SSA, these facilities are being created under the Total Sanitation Campaign. Whereas in existing schools, the gaps in water and sanitation facilities are being met under SSA.

Graph 1:2. Year wise achievement in construction of school toilets

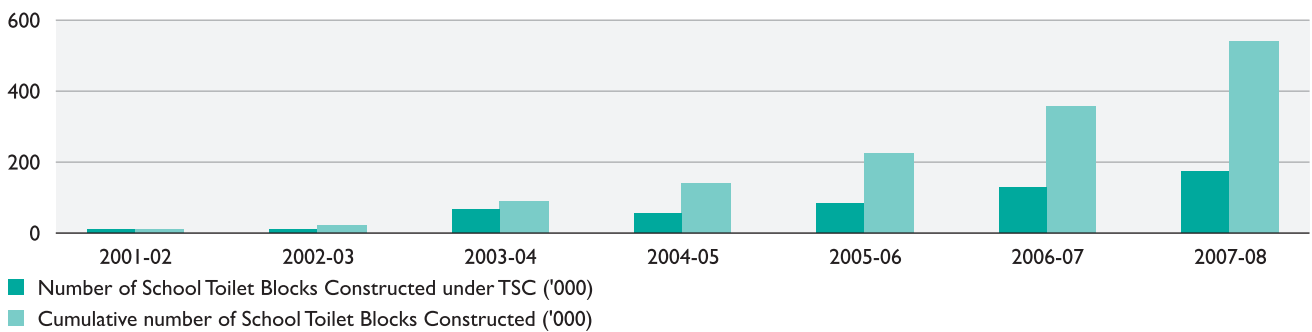

School Sanitation, Hygiene Education and TSC

The government is committed to 100 percent coverage throughout the country by the end of 11th Plan, with special focus on schools. All the government-run rural schools are to be covered under the TSC fund and private schools by their own resources, and separate toilets blocks are to be constructed for girls in all co-educational schools. Rural school sanitation is an entry point for wider acceptance of sanitation by rural people. Keeping this in mind, TSC outlines the following objectives for school sanitation coverage:

- To provide water and sanitation facilities in the schools so that the children from their early childhood can use the facilities and develop consistent habits of using such facilities.

- To promote the usage of toilets/urinals among school students, hand washing at right times (before and after eating, after using toilet) and other hygiene behaviour.
- To promote behavioural change by hygiene education and linking the same to home and community.
- To develop institutional systems within the schools so that the facilities and infrastructure created are maintained by the schools without any external support.
- To build the capacities of all stake holders, especially teachers, PTA, PRI etc. to ensure sustainability of systems.

The graph above depicts the progress and increase in the number of school toilets constructed under TSC over the past seven years.

TSC Provisions

- Separate toilets for girls and boys to be provided which are treated as two separate units with each unit entitled to Rs. 20,000 of grant jointly from Government of India and State Government.
- Funding for school sanitation in the TSC Project is provided by the Gol and State Government in the ratio of 70:30.
- Actual requirement of fund for all uncovered schools will be made available through TSC.
- Funds for hygiene education may be utilized from IEC component of TSC.
- Solid/liquid waste management to be incorporated in schools by utilizing TSC funds.
- Nirmal Gram Puraskar - Gram Panchayats, Blocks and Districts can apply if they have achieved the following conditions (a) 100 percent sanitation coverage of individual households, (b) 100 percent sanitation coverage of schools (c) are free from open defecation and (d) maintain clean environment.

SSHE and Convergence of Government Interventions

To meet the targets set for schools on safe drinking water supply, adequate sanitation facilities and hygiene education with special focus on gender, equity and disability issues, it is imperative that institutional arrangements be clearly defined for effective implementation. This programme involves various departments such as Education, Health, Panchayat and Rural Development, PHED, Women and Child Development, Tribal and Social Welfare, some external support agencies like UNICEF and concerned NGOs, PTA, SMC etc. at State and District level. Taking this into account, the government is trying to integrate the efforts of various departments which have provisions for different elements of SSHE for faster and effective outcomes. Inter-sectoral linkages are being forged on the following basis in most States:

- **State-level Action Plan and Inter-Sectoral Linkages:** In each State, a State Water and Sanitation Mission (SWSM) has been constituted with representation of various departments

such as Education, Health, Panchayat and Rural Development, PHED, Women and Child Development, Tribal and Social Welfare, etc. The SWSM functions as a task force and is involved in the development of State-level Action Plans highlighting vision, goal, target coverage, implementation, time plan, inputs and outputs, monitoring, etc. The action plan is expected to reflect the mode and means for fund mobilization for the water, sanitation and hygiene education programme, which may be pooled from TSC, ARWSP, Prime Minister's Gramodaya Yojana, SSA, Finance Commission awards, State resources and other sources.

- **Setting up District, Block and Village-level Committees:** A decentralized institutional structure

is important for effective decision making, implementation and monitoring for the school water supply and sanitation component. At the district level, District Water and Sanitation Mission or Zila Panchayat, is implementing TSC in a decentralized manner. Formation of Block-level committees comprising Block officials is desirable but is not happening in many states. At the Gram Panchayat level, Village Water and Sanitation Committees are formed where GPs are very large.

- **School Water and Sanitation Committee:** Involves students and teachers for mobilization, implementation, O&M, school-based activities, community linkages, etc. These committees are formed at the school level involving PTAs, SMCs and VECs, whichever exist in that village.

Section 2

Elements of SSHE

The SSHE programme has two major elements:

Hardware Component

The total package of drinking water, hand-washing and sanitary facilities along with arrangements for proper disposal of solid and liquid waste, available in and around the school compound.

- Separate toilet complexes for girls and boys with a minimum of one toilet and two urinals each irrespective of the number of students. The number of toilets and urinals should be increased depending on the strength of students, as per the norms defined in Part 2 of this note.
- This also implies that technologies will be child/gender and disabled-friendly, environmentally appropriate and sustainable.
- For upper primary schools, arrangements for menstrual hygiene management in girl's toilet complex, such as incinerators.
- Separate hand washing facilities for washing hands after using toilets and for washing hands before and after eating/mid-day meal.
- Provision of safe drinking water and adequate water for hygiene throughout the year using low-cost, community-owned solutions such as force lift hand

pump technology, rooftop rainwater harvesting etc. where appropriate.

- Platform around drinking water source along with proper waste water disposal arrangements.
- Proper arrangements for garbage disposal (may be a simple compost pit) and waste water management.

Software Component

This includes health and hygiene activities aiming at promoting conditions in schools and practices by school staff and children that help to prevent water and sanitation-related diseases.

- Hygiene education in the school on key hygiene behaviours.
- Setting up institutional structures for maintenance of watsan infrastructure.
- Food hygiene, especially where schools provide meals.

Other desirable elements of SSHE are:

- Regular health check-ups and de-worming in schools.
- Counselling and facilities for menstrual management.
- Adaptations suited to the disabled in at least one toilet.
- Water quality monitoring.

Table 1:1. Activity Items of Hardware and Software Components of SSHE that may be taken up

Hardware	Software
<ul style="list-style-type: none"> • Construction of toilets in all types of government schools from TSC funds i.e. Primary, Upper Primary, Secondary and Higher Secondary. Emphasis should be given on separate toilets for girls in schools, i.e. one toilet block consisting of one latrine, two or three urinal points (one each for girls and boys) along with a water storage tank and hand washing facilities. • Girl's toilet design inclusive of arrangements for proper menstrual hygiene management in the form of incinerators/covered bins. • Install hand pump in the schools for <i>provision of drinking water</i> where there are no such sources with support of other schemes and agencies such as ARWSP/SRP/SSA/others. • Platform around the drinking water source to ensure proper waste water disposal. • Provisions for <i>hand washing facilities</i> and other materials for example bucket, mugs, soap tray, brush, capacity drum for drinking water etc. • Separate hand washing facility for use before and after mid-day meals. • Construction of <i>drainage system</i> for solid and liquid waste disposal. Construction of garbage pit, soakage pit, place for washing utensils and cooking and storage place for food for the mid-day meal. • Plantations for a neat and clean school compound and lighting, ventilation for a clean classroom environment. • Rainwater harvesting and water conservation may also be taken up. 	<ul style="list-style-type: none"> • Inter-sectoral coordination: pooling of resources/ideas among departments like District Mission, DRDA, PHED, Education, Health, PR & RDD, Social Welfare and Tribal Departments. • Formulation of objectives, outputs/results and an action plan. • School awareness/IEC on school water supply, sanitation and hygiene and active participation of students and teachers. • School committee members, students and the public to be motivated to improve the school environment with fencing, planting of trees and proper maintenance of the sanitary block with their own contribution. • Organize a <i>campaign in the village</i> through the school for adoption of water points, sanitary latrine, garbage pit, soakage pit, smokeless chulla, water storage tank and other sanitary provisions in the household as a package. • Sensitizing and training of engineers/GP/District Panchayat/ RDD and all other key district and block-level functionaries on SSHE and its management. • Training and orientation of community and parent groups such as School Management Committees, VEC, PTA leaders, PRIs and teachers to train other frontline workers/NGOs/ masons/motivators etc. in promoting sanitation and other activities in the community taking the primary school as a focal point. • Formation of school health clubs to discuss, take responsibility and participate in making provisions for water and sanitation facilities in the schools as well as maintaining these facilities. • Health and Hygiene Education Activities among school children on use of safe water and toilets, hand washing at critical times, safe disposal of solid and liquid waste, water and food handling and personal hygiene habits by: <ul style="list-style-type: none"> • School health check-up and de-worming. • Demonstration activity through life skills. • Curriculum development and incorporation. • Daily school themes and exposure visits.
<ul style="list-style-type: none"> • Repair and maintenance of watsan facilities such as toilets, urinals, water points, water storage, hand washing facilities, garbage pit, etc. • Identify leakage, cracks, and breaks and repair them or get repairs done. • Ensure quality in design, and construction. • Quality checking and certification. • Checking of norms, specifications, standards and quality. 	<ul style="list-style-type: none"> • Protection and maintenance of watsan facilities by SMC/ SWSC/PTA which includes resource mobilization and roster of responsibilities (irrespective of caste and class) for making sure all children wash hands with soap after going to the toilet and before eating. Involving children in cleaning the toilets, cleaning water point area and filling water reservoir, checking for leaks, cleaning the compound, etc.
	<ul style="list-style-type: none"> • Monitoring and evaluation of the programme and its impact with a focus on self assessment by regular follow-up and surveillance through weekly visits of the District Implementation Committee, school-based monitoring system, external assessment, review missions, etc.
	<ul style="list-style-type: none"> • Linkage to schools with families and community
	<ul style="list-style-type: none"> • Documentation of the experience and case studies of the school sanitation programme for sharing with others and for further expansion.

SSHE implementation at school: Necessary inputs and efforts

The school water supply, sanitation and hygiene education programme needs to be implemented carefully. In fact, it is necessary that an implementation plan be prepared at school level to cover various components of SSHE such as IEC, physical infrastructure, hygiene education, O&M, monitoring, and so on. The plan should inform how the programme will be carried out at school and who is responsible for what, with a time line at each point with required inputs. For effective implementation of a SSHE plan, the following are essential:

1. Active Children:

In a school sanitation programme, children learn and practice good hygiene habits. Children can also experience working together, being tolerant and building self-esteem. In good programmes, girls and boys are responsible for:

- Their own personal hygiene.
- Regular and correct use of facilities.
- Washing hands after using toilets and before eating.
- Keeping the environment clean.
- Participating in hygiene education activities, both inside and outside classrooms.

2. Trained and active teachers:

One or two teachers should be in charge of the programme. They are usually responsible for:

- Working with community groups.
- Helping to plan the location and design of facilities.
- Educating children.
- Organizing children for the activities.
- Organizing and managing school watsan/health committees.
- Monitoring the programme in the school.
- Attending meetings and conferences.
- Educating children outside the school, visiting communities, organizing programmes by the children in the community.

3. Availability of Facilities:

School water and sanitation facilities need to be adapted to the needs of children in different age groups and must be appealing for them to want to use these facilities. The programme should ensure that engineers and construction agencies install facilities that are locally appropriate to ensure proper use and operation and maintenance of the facilities. The following facilities need to be constructed:

- Separate toilets and urinals for girls and boys.
- Separate hand washing facilities for use after visiting the toilet and before the mid-day meal.
- Water supply for drinking and hand washing.

- Healthy class rooms and play grounds (greenery, cleanliness of surroundings, lighting, chalk boards, desks and benches etc.).
- Garbage pit and soakage pit.
- Arrangements for menstrual hygiene management in girls toilet, especially in upper primary schools.

4. Health and Education through better hygiene habits:

The objective of school water supply, sanitation and hygiene education is to ensure that the health and education of school children improve through better hygiene behaviour. SSHE should aim to promote hygiene practices among school children by use of safe water, use of toilets, hand washing at critical times, safe disposal of waste, use of footwear and proper food handling. For example, the following activities can be incorporated :

- *School health check up and de-worming activity:* For instance, six-monthly or yearly de-worming activities may be planned with the provision of regular visits by PHC doctors/ANMs for school health check ups. Coordination with the Health Department may be established.
- *Demonstration activity* using a life skills approach for imparting health and hygiene education on the issues of hand washing – both after defecation and before and after eating – water and food handling, use of footwear, toilet use, personal hygiene, cleaning the toilets, cleaning of the school campus and plantations in the compound, disposal of solid and liquid waste, home and village sanitation, etc.
- *Curriculum development* and incorporation of hygiene education in the curriculum. Coordination with Education Department may be established. It should be based on child-friendly learning and innovative teaching mode.
- *Competitions* among children to encourage learning through quiz, painting, debates, games, songs, wall painting, slogan writing, etc.
- *Daily school themes* on water and sanitation, for e.g. on Monday handling of drinking water, Tuesday personal hygiene and so on. Observance of a Sanitation Day once a week along with a sanitation drive in the village and around water sources involving school and community.
- Message at school assemblies on health and hygiene.
- Exposure visit to schools which have better facilities and practice good hygiene behaviour.
- Linkages between school, family and community.

5. School Child Cabinets/Health Clubs:

These are the institutional arrangements for children to carry out water and sanitation programmes in schools. Their size varies from about 10 children to 30 children.

Besides these, class-based watsan/health clubs can also be formed. These cabinets/committees would perform various functions:

- *Decision making* - Identify hygiene problems in the school and community and make plans for solving these problems. They can also decide the location of the facilities.
- *To make a roster of duties, apportion responsibilities* and ensure children fill the water reservoir, clean around the tank and hand washing facility, check for leaks, maintain water pots in class rooms and children check other children for cleanliness at the beginning of the day. The watsan club members make sure that all children wash hands before and after eating and after going to toilet, help to organize children for cleaning the compound, make sure the classrooms are neat and remove the trash. In the morning, children clean the classroom by turn. They also ensure that children and teachers clean the latrines by rotation.
- *Child-to-Child, Child-to-Home and Community links* - Members of the committee may ensure that older children help to teach younger children. Children can monitor the use of facilities by other children. They can persuade parents to construct toilets and also teach them good hygiene habits. They can participate in village cleaning programmes, visit other schools, organize sanitation demonstrations and undertake games and competitions to promote hygiene and sanitation.

6. Operation & Maintenance of Facilities:

Maintaining cleanliness in and around water point areas and toilets is essential for the success of the school water, sanitation and hygiene education drive.

Drawing 1:1.

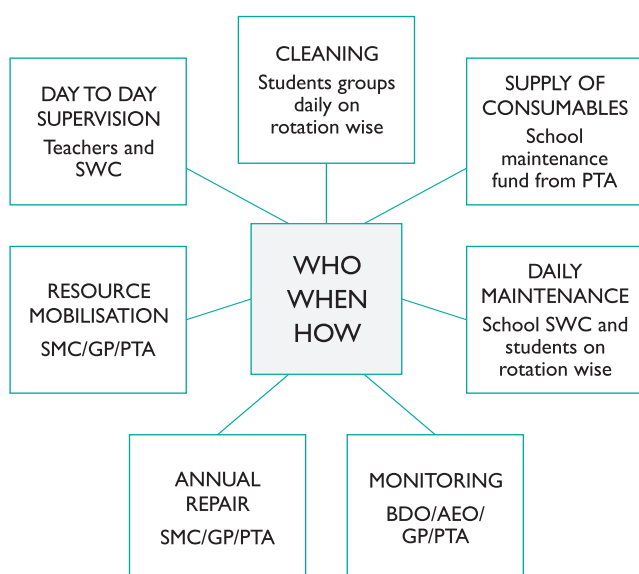

The O&M responsibilities may be handled by child cabinets/health clubs under the overall supervision of teachers/head teachers. The students should be assigned tasks by rotation. The role of school watsan committee/school management committee and PTA, etc. should be well coordinated which in turn ensures the following:

- Resource mobilization for O&M funds, i.e. for soap, brush, bucket from PTA, SMC, VEC, etc. (may be on an annual basis).
- Roster of responsibilities (irrespective of caste and class) to make sure all children wash hands with soap before and after eating and after going to the toilet, and to involve children in cleaning the latrines, water point area and fill the water reservoir, check for leaks, cleaning the compound, etc.
- Creative use of IEC and training to ensure school-led O&M.
- Drawing up of maintenance schedules and allocation of responsibility such as who will clean and who will monitor on a rotation basis among students. State/Districts may issue suitable official directions on this issue of student's involvement.
- Manage stock of parts, tools and supplies.
- Conduct survey on O&M improvement, meetings and respond with solution against user complaints.

7. Supervision and Monitoring:

Monitoring should be an ongoing activity in school sanitation and hygiene programmes. Monitoring is far more than collecting information to 'see how things are going'. It is meant to improve programmes and activities over the short term. Monitoring involves checking, analyzing and making mid-term correction to improve a situation. Thus, SSHE monitoring is not merely the upward flow of information about implementation and finance. Monitoring indicators should be kept simple, short and comprehensive.

Conventional monitoring and review through functionaries may be followed. In addition, independent monitoring and concurrent evaluations should also be planned to generate timely, reliable and usable information. These may be:

- Regular school visits by Panchayat members, BDOs, officials of Health and Education departments, PTA and SMC members.
- Regular review meetings at different levels.
- School-based participatory monitoring using techniques such as monitoring charts, mapping, physicals checks, etc. by students and teachers (checklist to be prepared by the students and teachers and school-based indicator to be developed).
- Community visits to schools.
- Quality inspection/review teams.

- Conventional report system (formats and progress reports – monthly and online reporting).
- Periodic evaluation and assessments for course correction.
- Impact surveys by independent agency such as mid-line survey and end-line survey.
- Documentation such as case studies and success stories.

8. Linking school to parents, homes and community:

It is very important to have active participation of the community in the entire programme for its sustenance

and for proper maintenance of facilities. Various activities and ways in which parents/communities can be involved in the process are:

- Have strong trainees and local groups in the community to support the programme.
- Ensure parents and the community understand the purpose of the programme.
- Participate in deciding the design option and location of the facility.
- Take part in the hygiene education programmes.
- Contribute for the O&M of the facilities either financially or supervisory.

Section 3

Key lessons from programme implementation

SSHE programme as a part of the Total Sanitation Campaign is being implemented since 1999. In the process, there have been a number of learning points from various States. Some of these are mentioned below:

1. Institutionalized system a must for O&M of facilities:

It has been widely accepted that when students play an active role in the O&M of school infrastructure, they not only learn more by doing things themselves but also gradually adopt the desired behavioural habits of using the facilities provided in the schools. Also, lack of coordinated efforts to have institutionalized arrangements for O&M by students may lead to these facilities not being maintained and sustained in the longer term.

Behaviour patterns are very quickly transmitted between children at school as well as the outside community.

The case study from Jharkhand narrates one such successful example.

2. Running water is absolutely essential for inculcating hygiene practices among children and also for proper maintenance of the toilets:

Experience over the years has shown that wherever running water is made available inside the toilets and at hand washing points, promotion of hygiene behavior especially cleaning the toilets by pouring water after use and washing hands, has had a positive impact. Running water makes it easy for the teachers to ensure that students practice these

Case Study: Child Cabinets in Jharkhand

Bankati Middle School of Ghatsila, East Singhbhum district, in Jharkhand has become a role model for the district. The well-managed, dirt free surroundings of the school with decorated gardens, cleanliness in all classrooms and toilets and accessible provision of water for drinking and hand washing, has turned out to be the identity for the school. The management of hygiene and sanitation facilities is done by the school children and is linked to their curriculum. The cleanliness and hygiene behaviour of the children is reflected in every corner of the school. The transformation in the school happened with the active role of the child cabinet and the support of the teachers.

On a typical day, school begins with a cleanliness drive including the cleaning of toilets. Regular checking of nails during prayers by the child cabinet inculcates hygiene behaviour among students. Storing water in the toilet's overhead tank is fun for the children as they exercise with the force and lift pump before starting their prayers and their mid-day meal. The children have made a provision for handwashing at the corner of the handpump platform where soap water is kept for cleaning hands before the meal. The same arrangement is there in the toilet for washing hands after defecation. The cabinet contributes a tiny amount for soap, broom, long-handle ladle and other items for watsan management and hygiene promotion. During the lunch break, the children first move to the hand pump and wash their hands with soap before they take their mid-day meal. After lunch, they wash their hands and drink water drawn with the long-handle ladle. At the end of the day, the watsan management concludes with the cleaning of the school.

The management by children is facilitated by provision for improved basic facilities like water supply, an exclusive toilet for girls, gardening facilities, provision of the force and lift pump and other child-friendly elements. The joint efforts of the district administration, Jharkhand Education Project, Drinking Water and Sanitation Department and UNICEF contributed to setting up the child-friendly environment that has reduced the drop-out of children. The role of the child cabinet is crucial for the sustainability of hygiene practices among students. The dissemination of hygiene practices are facilitated through child-to-child, child-to-parent and parent-to-community links and this has helped the Panchayat get the prestigious Nirmal Gram Puraskar in 2007.

Case Study: Force Lift Pumps dovetailing 12th FC grants in Uttar Pradesh

SSHE refers to a complete package of infrastructural facilities for water and complete sanitation and their effective use and maintenance leading to improved learning and healthy environment. Experience over the years has shown that one key intervention critical for proper use and maintenance of the provided facilities and promotion of hygiene behaviors is availability of running water. Manual filling of water to tanks for cleaning up toilets and washing hands do work initially but gradually the enthusiasm for this routine task fizzles out. Having piped/running water availability at all times has been an expensive alternative and funds have been a constraint for this component.

Uttar Pradesh in one of their studies in 2005 found that the acceptance of hygiene behaviors in schools was abysmal for which shortage of running water came out as one of the major impeding factor. In order to address this problem, UNICEF introduced the technology of Force Lift Hand Pump (FLHP), in around 500 schools of the state. With this low cost technology, water from an India Mark II Hand Pump could be raised to 12' height, from where, through piped distribution system, running water could be made available to the toilets and also to the wash basins. State government took a positive cognizance of this technological breakthrough and issued directives for the large scale replication of the technology. While directives were issued for its replication, there was no regular program or scheme to provide financial resources. It was agreed at the policy level that state has to use the funds available in 12th Finance Commission, which is meant to undertake miscellaneous infrastructural development works in a village. Every year, USD 146 million is being allocated under this fund to Gram Panchayats, and Gram Pradhan is given powers to make use of the fund, as per the local requirements. In 2006 U.P government issued a Government Order (GO), wherein it advised all the Panchayats to make use of financial resources from 12th Finance Commission for the conversion of normal HP to FLHP. This GO gave a boost to the conversion and now all hand pumps in the government rural schools are being converted to FLHP and running water facility is being ensured in schools, inside the toilets. Even Education department has taken initiative and has allocated resources for the conversion of 13,000 more schools, till March 2008. With the regular running water there has been marked improvement in the hygiene behavior not only at the school level but also at the community level.

FLHP is a simple manually operated technology, and does not require any electricity / diesel / petrol for its operation. Any functional IM-II/III can easily be converted into Force Lift Hand pump by introducing a Non Return Valve, Flange Gaskets and Overhead Tank along with a tap near the spout to store the spill over water to the tank. The water fills up to the over head tank in the normal process of fetching water from the hand pump and such a simple technique ensures adoption of hygiene behaviors to a large extent. The success of this initiative is now taken up by many other states and FLHP can now be seen in West Bengal, Madhya Pradesh, Assam, Bihar, Jharkhand, Chattisgarh etc. All the states are trying to scale up this initiative in all schools of the states.

behaviors without spending extra time and effort on fetching water from other sources.

3. Leveraging funds from other programmes for water and sanitation facilities in schools is possible: There are a number of other programmes that have provision for water and sanitation facilities in schools such as Sarva Shiksha Abhiyan, ARWSP for the water component, 12th Finance Commission, other funds available at the Panchayat level. To have a complete package of school sanitation, funds for certain components that are not being completely met out of TSC /SSHE component, can be leveraged from these programmes. Many states have successfully experimented with this convergence of funding for school water and sanitation provisions.

4. Simple Technologies work: As already mentioned, one key intervention critical for proper use and maintenance of the provided facilities and promotion of

hygiene behaviors is availability of running water. Manual filling of water tanks for cleaning toilets and washing hands do work initially but gradually the enthusiasm for this routine task fizzles out. Having piped/running water availability at all times has been an expensive alternative and funds have been a constraint for this component. States have experimented with the Force Lift Hand Pump (FLHP) technology which is very simple and effective in providing running water through overhead tanks where there is no electricity or regular power supply is not assured. This proves that there is scope to try out less expensive and simple methodologies in this programme.

The above case study narrates the above three learnings in one example of Uttar Pradesh.

5. Role of Teachers in SSHE -- Towards a safe future: Teachers play the most crucial role in this programme with the responsibility of day-to-day supervision of various

Graph 1.3. Trends of Enrollment

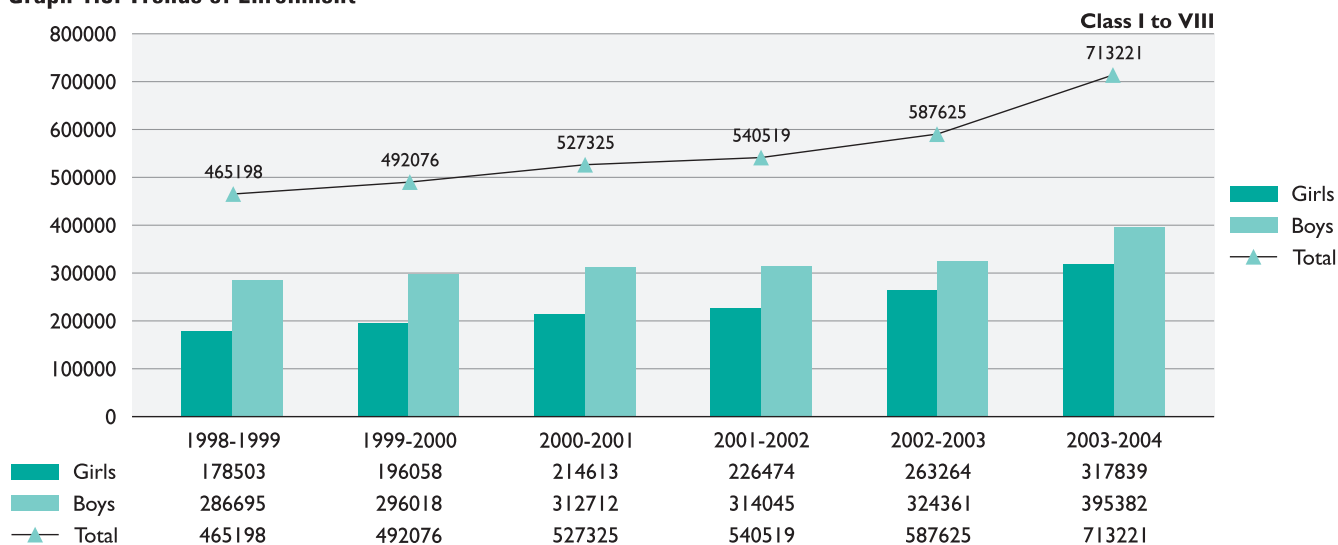

activities. The impact and the difference that a school-based programme is making can be best judged by the teachers of the school. Thus, their positive involvement is of utmost importance. There is evidence that the teachers of a school in Alwar district of Rajasthan successfully implemented the school sanitation programme and tracked the improving trends of student enrolment and attendance over the years with better sanitation facilities. Data on enrolment over five years showed 78% increase in girls and 38% in boys' enrolment. The involvement of teachers here is not limited to supervision of various hygiene practices but hygiene education plays an equally important role which leads to adoption of these hygiene practices. To achieve this, adequate Teaching Learning Material and proper capacity building of teachers is equally important.

6. Menstrual Hygiene Management – A realized need:

During the course of the programme, it was strongly felt that the sanitation agenda remains incomplete if the issue of menstrual hygiene including disposal of sanitary napkins at the school level is not dealt with, especially when gender-friendly approaches are planned. A few experiments were tried in a limited number of schools in Tamil Nadu and a low-cost incinerator was designed to be a part of the girl's toilet complex. These experiments have been hugely successful and have solved problems faced by adolescent girls who earlier preferred to stay home rather than attend school during menstruation.

There have been successful innovative experiments such as installation of sanitary napkin vending machines in schools which enables the adolescent girls to be better prepared to deal with menstruation if they are unprepared during school hours. These vending machines dispense single napkins when a two rupee coin is inserted and are easy to install in schools and other public places.

Incinerator for sanitary napkin disposal in Tamil Nadu

Both biodegradable and non-biodegradable waste can prove hazardous for health if proper and complete disposal is not done. Sanitary waste, especially solid and semi-solid waste, is more dangerous as it spreads infection rapidly and on large scale. In schools especially, disposal of sanitary napkins in girl's toilets is big problem from the health aspect.

In Tamil Nadu, low-cost incinerators for waste disposal have already been put to use in many rural schools, particularly in girls toilets and it costs about Rs 1500. The incinerator comprises a primary and secondary chamber and emission control systems with exit doors for ash removal – one in each chamber. Each chamber has a spout in its wall for disposal of soiled napkins and the wire gauze chambers on the other side of the toilet wall is used for collection of the soiled napkins. These dropped napkins and other waste are disposed weekly or as required by firing from the outside chamber, turning all the waste into ash.

Use of the incinerator has removed the inhibitions of the girl child and has made her more comfortable about attending school during menstrual days. Such technology should be installed in all toilets to ensure a clean and healthy environment for children, especially girls.

PART II

Norms and Guiding Principles



PART II and III of this technical note provide in detail the suggested norms for school sanitation, the principles around which school toilet complex designs should be framed ensuring proper use and maintenance, and points to be kept in mind while selecting a site for sanitation complex.

These two part and have been developed with technical input from VINYAS, Centre for Architectural Research and Design. We sincerely acknowledge and thank its Principal Architect Mr. Kabir Vajpeyi and his team for working in this project alongwith UNICEF and Government officials to develop the norms, principles and thereafter the inclusive design options. VINYAS has also reviewed the designs developed by few states that were already being used, and provided with modifications in these designs to meet the revised inclusive norms.

Section 1

Physical infrastructure under SSHE

In order to ensure an inclusive sanitation environment in schools with all the norms covered, a need was felt to develop a new and complete set of norms and options in the form of a fresh technical note with more designs addressing and incorporating the revised norms. As every state moves towards providing sanitation facilities to all schools, it was evident that a lot of necessary details were being missed out during the process of designing and construction. These details include proper hand washing areas, special gender, disabled and child friendly designs, low maintenance finish and similar concerns.

To come up with a list of complete, essential and desirable components and norms for school sanitation, a series of consultations was held with experts from the Sanitation and Education sectors. Based on these consultations, experience from the field and guidelines of the National Building Code, a comprehensive list has been drawn up. Although the essential items are non-negotiable for an effective inclusive learning environment, the desirable ones can be adapted depending on local availability of resources, cultural and social trends, etc.

TSC has a target of covering all rural schools with water and sanitation facilities and these guidelines will enable effective and inclusive implementation of the SSHE programme with a certain degree of uniformity of designs and essential components which are incorporated according to suggested norms.

I. Essential and desirable components of physical infrastructure under SSHE

1. Essential components

i. Specially designed girl's toilet with following:

1. Squatting area - rural pan.
2. Adequate availability of running water for washing.²

3. Hooks for hanging clothes.
4. Niche to keep sanitary napkins.
5. Opening for natural light and ventilation.
6. Door with latch.
7. Floor with adequate slope and maintainable durable finish.³
8. Dado with neatly maintainable durable finish.
9. Lightweight ⁴ roof cover.
10. At least one toilet for girls in the category of Children with Special Needs (CWSN) with the necessary provisions.
11. At least one incinerator in girl's toilet block.

ii. Girl's urinals with following:

1. Partition between urinals.
2. Screen door in at least one urinal up to 1500mm height.
3. Opening for natural light and ventilation.
4. Floor made of ceramic tiles for easy maintenance with adequate slope and easy to maintain durable finish.
5. Dado with neatly maintainable durable finish.
6. Lightweight roof cover.

iii. Boy's toilet with following:

1. Squatting area - rural pan.
2. Adequate availability of running water for washing.
3. Hooks for hanging clothes.
4. Opening for natural light and ventilation.
5. Door with latch.
6. Floor with adequate slope and neatly maintainable durable finish like good cement flooring/ceramic tile flooring.
7. Dado with neatly maintainable durable finish.
8. Lightweight roof cover.
9. At least one toilet for boys in the category of Children with Special Needs (CWSN) [Boys] with necessary provisions.

² There can be various options for this depending upon types of water arrangement in school. If there is bore-well/hand-pump supply, the water can be lifted to fill an overhead water tank which can be connected to taps to provide running water in toilets. If there is no borewell/hand pump, then alternative arrangements for manually filling water to a raised tank connected to taps in toilets can be considered. If this is not possible, a small bucket can be provided in the toilet that can be filled with water outside and taken inside by a user child.

³ There can be good cement flooring or glazed ceramic tile flooring, depending on availability of material and skill in the area. In either case, use of lighter shades of colours is desirable.

⁴ The roof cover can be lightweight only if there are no plans for having a water tank on top or there is no possibility of making the toilet double storey in future.

iv. Boy's urinals with following:

1. Partition between urinals.
2. Opening for natural light and ventilation.
3. Floor made of ceramic tiles for easy maintenance with adequate slope and neatly maintainable durable finish.
4. Dado with neatly maintainable durable finish.
5. Lightweight roof cover.

v. Hand wash facility for toilets and urinals with following:

1. Separate hand wash facilities for boys and girls within respective toilet blocks.
2. Taps at child-accessible height.
3. Place to keep soap at child-accessible height.

vi. Hand wash-cum-safe drinking water⁵ facility for mid-day meal kitchen area with the following:

1. This will be an additional facility to wash hands before and after the mid-day meal outside or away from toilet blocks (depending on space) because it is unlikely that children would go inside the toilets to wash hands before eating.
2. Taps at child-accessible height.
3. Place to keep soap at child accessible height.
4. Waste water kitchen garden/herbal garden.

vii. Adequate solid and liquid waste disposal system.

It is important that all existing and new schools provide the above-mentioned components.

2. Desirable components

The resources available for SSHE may not be uniform across schools. It is important that certain minimum essential items of SSHE (all those mentioned above) are provided in each school, while leaving scope to improve the facilities if there are resources. All the optional components will add to the aim and objectives of SSHE in a qualitative manner. It would be a good practice for schools to keep the following optional components for future planning, even if they are initially able to provide only the essential components:

1. Flushing system (recycled water from wash area) for toilets and urinals.
2. At least one mirror in a toilet block.
3. Graphics and visuals depicting hygiene issues related to use of toilets.
4. Graphics and signage in school for locating the following facilities:
 - a) Toilets and urinals.
 - b) Hand wash facilities.
 - c) Drinking water (along with capacity of water tank, pot if any).
 - d) Solid and liquid waste disposal system.
 - e) Hand pump with force lift.
 - f) Rain water harvesting (RWH) system (along with a graphical diagram of the system near the RWH system to help children understand it).

⁵ It is assumed that the school authorities will ensure that drinking water is potable and if the water is being drawn from an underground source, it is at a safe distance of at least 10 meters from the leach/soak pits attached to school toilets or nearby toilets or from the community sewage water drain.

Section 2

Norms for water and sanitation facilities in schools

Determining the need:

a. School toilets:

To begin any School toilet design exercise, it is first important to establish the need and then follow the norms for provision of facilities. The norms for school toilets, urinals and other wash facilities have been defined in the National Building Code (NBC). However, it may be noted that the norms must be simple, pragmatic and based on:

- Field experience of the ground situation(s).
- Observed pattern of usage of these facilities.
- Methods that connect directly with planning of school classrooms and other infrastructure provisions (planned for multiples of 40 children).

For example, in most day-schools the frequency of use of urinals is much higher than toilets as compared to residential schools. Most norm-based calculations are envisaged for 'peak' load situations of usage. If such peak times can be offset by creative planning of the time table, the provision of infrastructure

may be optimised without compromising on quality. For example, if in larger schools, the lunch break is staggered for primary and middle schools, the number of urinals and toilets to be provided may be reduced without causing any inconvenience and ensuring better utilization of available resources. Hence, one toilet for every 80 children has been suggested.

It is also noticed that school toilets are being constructed across the country without following any clearly defined norms. Certain criteria need to be kept in mind while deciding on the number of and provisions provided to a structure. There are studies on queuing time for toilets in schools and how many toilets and urinals should be made available according to the number of students (both boys and girls). The following norms have been developed for school sanitation keeping the above criteria in mind. Separate tables have been prepared for non-residential schools (table 2.1) and residential schools (table 2.2) since the pattern of usage differ in either case.

Table 2:1. Norms for provisioning of SSHE facilities (for day schools without residential facility)

S.no	Provision head*	Numbers to be provided	Remarks
Girl's toilet			
1.	Girl's toilet squatting pan*	1 unit for every 40 girls + lady teacher	Day school, without residential facility.
2.	Girl's toilet for CWSN	At least 1 unit in a girl's toilet block	In case only 1 girl's toilet is needed in a school, this single toilet must be designed for CWSN. In case more toilets are needed, the others need not cater to CWSN.
3.	Wash tap in girl's toilet*	1 tap in each toilet	Located conveniently for use by the child as well as adult.
4.	Clothes-hanging hook*	Hooks in each toilet	At least 2 hooks at different child accessible heights – suitable for a 5-year-child to an adult.
5.	Niche in wall*	1 niche in each toilet	Recessed in the wall to keep sanitary napkins.
6.	Ventilation arrangement*	1 opening for ventilation in each toilet	Size 450x450mm at a height and location that allows sunlight to penetrate for few hours in a day for self drying.
7.	Door*	1 door in each WC	Door to be 2100mm high with child accessible latching arrangement.

contd....

S.no	Provision head*	Numbers to be provided	Remarks
Girl's urinal			
8.	Girl's urinal*	1 urinal for every 20 girls	With partitions. Two minutes waiting/queuing time for using the facility at peak hours.
9.	Self cleaning system	1 flushing system in each urinal	Any flushing system that washes the soiled surface with minimal water is acceptable. Use of recycled water is desirable. Use of standard urinal or toilet flush is not compulsory.
10.	Ventilation arrangement*	1 opening for ventilation in each urinal	Height and location that allows sunlight to reach the floor for few hours in a day for self drying.
11.	Screen door	1 door for each urinal	Screen door to be 1500mm high with child-accessible latching arrangement.
Boy's toilet			
12.	Boy's toilet squatting pan*	1 unit for every 80 boys + male teacher	Day school, without residential facility.
13.	Boy's toilet for CWSN	At least 1 unit in a boy's toilet block	In case only 1 boy's toilet is needed in a school, this single toilet must be designed for CWSN. In case more toilets are needed, the others need not cater to CWSN.
14.	Wash tap in boy's WC*	1 tap in each WC	Located conveniently for child as well as adult use.
15.	Clothes-hanging hook*	2 hooks in each WC	Hooks at different child-accessible heights – from 5-year-child to adult.
16.	Ventilation arrangement*	1 opening for ventilation in each toilet	Size 450x450mm at a height and location that allows sunlight to penetrate for few hours in a day for self drying.
17.	Door*	1 door in each WC	Door to be 2100mm high with child accessible latching arrangement.
Boy's urinal			
18.	Boy's urinal*	1 urinal for every 20 boys + gent teacher	With partitions.
19.	Self cleaning system	1 flushing system in each urinal	Any flushing system that washes the soiled surface and works with minimal water is acceptable. Use of recycled water is desirable. Use of standard urinal or toilet flush is not compulsory.
20.	Ventilation arrangement*	1 opening for ventilation in each urinal	Height and location that allows sunlight to penetrate to the wet wall/urinal pan and floor for a few hours a day for self drying.
Hand wash			
21.	Hand wash (toilet/urinal)*	Minimum of 2. One wash tap for every 20 children	Can be provided as common/ separate for girl's and boy's toilet blocks.
22.	Hand wash – MDM kitchen*	Minimum of three. One wash tap for every 20 children thereafter.	To be provided near MDM kitchen. Preferably, should be segregated and separate from toilet hand wash for hygiene purposes.
23.	Soap tray with soap*	1 with every two wash taps	Soap type can be according to feasibility.
24.	Mirror	1 in each hand wash unit	
25.	Wash water storage tank*	Minimum 500 litres for a school of up to 100 children. Subsequent calculation @ 5 litres per child.	The tank capacity does not include a buffer storage reserve in case of emergency.

Table 2:2. Norms for provisioning of SSHE facilities (for residential schools with boarding facility)

S.no	Provision Head*	Numbers to be provided	Remarks
Girl's toilet			
26.	Girl's toilet squatting pan*	1 unit for every 20 girls + lady teacher/supervisor	Residential school with boarding facility.
Boy's toilet			
27.	Boy's toilet squatting pan*	1 unit for every 20 boys + gent teacher /supervisor	Residential school with boarding facility.
<i>It may be noted that provisions mentioned in 26 and 27 will replace provisions mentioned in 1 and 12, respectively in day schools table 1.1. All other provisions in table 1.1 will also apply for residential/boarding schools.</i>			

• All marked with '*' are essential and mandatory.

• For details of sizes and anthropometrics, refer to Section 4 on Key Data Required to Design Toilet Blocks (part II).

The following must be noted:

- It is mandatory to make separate toilets for girls in the school. Special and exclusive provisions for girls and ladies must be made in these toilets.
- Exclusive toilets must be avoided altogether for teachers or head masters/mistresses. Toilets should have an universal design approach for use by children, CWSN as well as adults.
- In the spirit of inclusive education, toilet designs must be developed with the assumption that CWSN are attending and will attend the schools in larger numbers in times to come. Under the act "Persons with Disabilities" (Equal Opportunities, Protection of Rights and Full Participation) at 1996 enacted by the Government of India in January 1996 and passed by the Indian Parliament, it is mandatory that amenities in school are accessible to each CWSN. The design must address the needs of the types of CWSN attending school and at least one toilet + urinal in the boy's and one in the girl's toilet block must be accessible to CWSN.

Drinking water provision

In a school, provision of drinking water must be made as per the following norms. The actual requirement may vary according to the climatic conditions, physiological needs and other factors.

Table 2:3. Norms for Drinking Water

Drinking water			
1.	Safe drinking water source	At least 1 source inside the school premises, irrespective of whether there is another one outside or near the school campus.	A dedicated safe drinking water source for a school is a must. Hand pump with force lift is desirable for lifting water. Potability of water to be tested for safety as per prescribed schedule. Source to be located atleast 10 m away from toilet soak pit.
2.	Water storage tank	Minimum 500-litre tank for every 100 children including buffer reserve. At least 5 litres per child to be provided.	The tank capacity assumes a buffer storage reserve in case of emergency or maintenance work, etc. for two days.

• All marked with '*' are essential and mandatory.

• For details of sizes and anthropometrics, refer Section 4 on Key Data Required to Design Toilet Blocks (part II).

Drinking water may be provided through any of the following modes:

1. Tested hand pump, bore well or any other traditional water structure.
2. Piped drinking water supply based on ground or surface water.
3. Rain harvested water (after it has been treated or found safe for drinking).

Section 3

Guiding Principles for Designing of School Toilets Blocks

Facilities designed for School Sanitary Complexes have somehow never followed a uniform pattern and mostly have not been provided equal importance as other infrastructure in the schools, even though they form an important component of school education. Good design of sanitation facilities in schools can have a cascading effect in popularising the concept of sanitation and developing young ambassadors (school children) of good hygiene. Since India has great diversity of geography, culture, social systems, needs, a design will have to sensitively respond to specific local conditions. Sites for toilets are varied and different in shape, size, clearance, orientation, soil conditions, climatic conditions, user requirements, resource availability, etc. A single uniform design cannot meet all the differing requirements. In other words, there is a great need for flexibility to suit a particular situation. At the same time, there are certain basic principles that are generic and encompass the larger national vision of SSHE in totality and will govern the design framework. These principles are common and provide enough guidance to allow designs to be evolved at the local level. Following are the basic guiding principles to be kept in mind while designing School Sanitation facilities.

- 1. Match the function and investment.** There are cases when schools with less number of students have bigger than needed, over-designed sanitation complexes. Also there are schools which do not have adequate number of facilities. Provision of amenities must be based on actual need in a school since the investment made should be optimally utilized and not go waste.
- 2. Integral to overall school plan.** Very often, school sanitation facilities are developed as an add-on to the school with little linkage to the overall school development plan. This kind of piece-meal approach does not contribute to improving the overall school environment. Design provision must be made integral to the overall school plan, match with the school ambience and not be isolated from its present and future needs. It should be such that any new provision or enhancement of an existing provision merges seamlessly and makes the school activities function more efficiently.

- 3. Child-friendliness.** Most planning-related decisions are taken by adults, with the underlying assumption that they know what children want. However, it has been found that very often this is not true. Visit a school and it is very likely that a mason has made a chalkboard at a height comfortable only for an adult; the carpenter has fitted the hardware at heights not considering children's reach or the plumber has fitted taps and urinals at a height suited to adults. Obviously such design decisions are not child-friendly, even though the facilities are supposed to be used by children. Child-friendliness is a basic guiding principle to make every small provision useful for all children attending the school. It is important to design keeping the child in mind as the prime user and beneficiary of the facilities created. This implies addressing needs of smaller

Drawing 2:1. Hardware fittings at child accessible heights

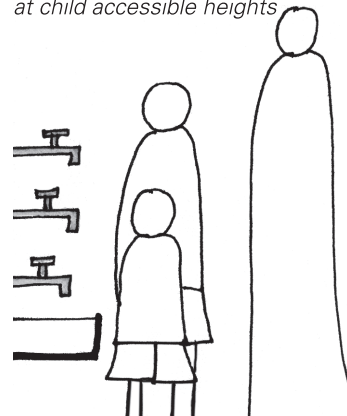

children, girls and boys in a way that ensures they can independently use the facility once they are trained to do so by adults. A child-friendly environment will, perhaps, also invite children to use the facilities that they may not have at home or have no prior experience in using.

- 4. Modular in nature for flexibility.** To be flexible and yet address all design concerns involves some basic components that can be arranged in different ways. This calls for a 'modular' approach, where each of the components like WC, urinals, wash, storage, can be in modular sizes so that they can be interchanged to suit a particular requirement. Hence, the urinals can be interchanged with WCs or vice versa or a wash facility can be interchanged with storage facility, etc. to suit a particular site situation. They can also be 'mirror-imaged' if required. The modular nature of design will also help in module-based expansion of

Drawing 2:2. Modules can be combined in different ways

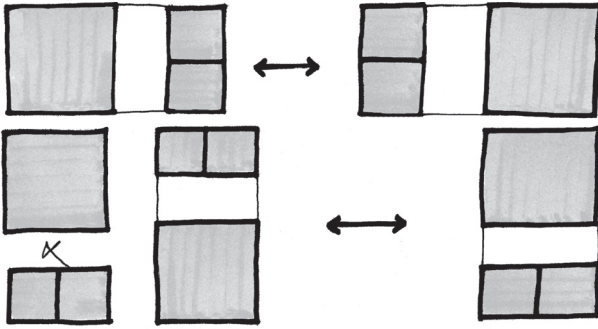

facilities created. This will enable flexibility to make site-specific adaptations. It will also help in estimating and costing based on modules.

5. Expandable core. Schools, today, are undergoing a transformation. Enrolment and retention rates are increasing as SSA is reaching so far un-reached children across the country. According to the latest figures made available by the Department of Elementary Education and Literacy (DoEEL) under the Ministry of Human Resource Development (MHRD) of Government of India (GoI) in October 2007, there was a gap of about 6.97 lakh classrooms across the country by the end of the 10th Plan (as on 31st March 2007). If the future requirement of the 11th plan period is also included, this gap is 9.45 lakh classrooms. This has a direct bearing on the number of children currently attending schools and those who will attend in the near future. It is clearly evident from the above that:

1. There already exists a huge demand for new toilets and drinking water facilities in schools across the country.
2. While the above mentioned data does reflect that the provision of toilets and drinking water supply is present in several lakh schools, it does not clearly indicate if these provisions are as per norms. Many schools may have the provision, but still fall short of actual need based on the number of children and teachers attending the school. Hence, the numbers mentioned above, may be an underestimate of the actual requirement.

As there is more infrastructural provisioning (new schools, additional classrooms, etc.), larger numbers of children are expected to attend schools. Hence the toilets and drinking water facilities may need further augmentation or expansion soon or in the near future. While the design must cover all the children currently enrolled in the school as per norms, they must also be expandable in different ways (as per space availability and future requirements), towards future needs, based on the norms. This must happen without duplicating resources and without affecting the core. The core design must include all essential and basic facilities. It must have the inclusive

toilet, urinal, hand wash, storage space for cleaning, water storage, leaching and soak pit etc. Any expansion required, can happen as an add-on on this core, thereby optimising and saving resources. Supervision at the time of developing the core may be intensive, but the same may not be required for the expansion. The design must be expandable in the front, the side, the rear or on all

Drawing 2:3. Toilets/Urinals expandable at different directions

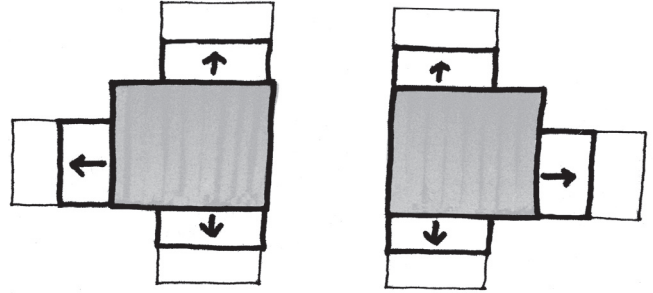

sides, as the case may be. Further, this expansion need not be done in one go and can be of incremental nature with modules of either or all sides. It is thus important to keep sufficient provision of space and clearance from existing buildings/boundary walls/trees or other site features while laying out the core design to allow it to effectively expand without problems in future. Location of the leaching or soak pit will also have to address this concern. During expansion, it must be ensured that the light and ventilation of the core is least affected.

6. Address typologies of site shapes and form: A prescribed toilet design, if blindly followed, may not be suitable for all schools. In most cases there is lack of proper site selection leading to many problems later. Two typologies of space are typically available for toilets at most school sites – linear and 'L' shaped

Drawing 2:4. Site planning of toilet blocks in different directions

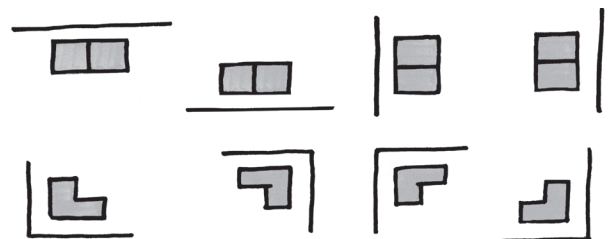

(corner type). The core design and its expansion must address these typologies for practical implementation on sites. The same design may not be able to cater to the two different typologies and separate sets of designs must be developed. In hilly regions there may be more typologies of different slopes that need to be addressed.

7. Universal and inclusive: There has been a growing recognition of the fact that Children with Special Needs do not and cannot attend school due to lack of proper

Drawing 2:5
Stool over Indian WC

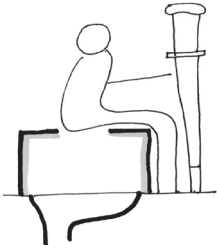

Drawing 2:6
Design for CWSN

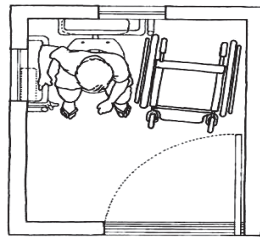

facilities in schools in general and toilets in particular. Thus the design at the core must be universal and inclusive so that it can be used by all – children, CWSN, teachers and other adults. It must be ensured that the WC can be used by all. One of the urinals should be large enough for an adult, the wash taps and hardware have to be designed and located in a way that they can be used by all. For inclusiveness, grab bars are to be provided that can be used by children as well as adults. For users with physical or other impairments, a stool type commode can be used over the Indian WC. This has also been done as the Indian WC is more commonly used in rural areas. For wheelchair-driven users, there should be a minimum of turnings and paths should be as direct as possible. The wash area should also be universal and accessible to all and be located along the natural path of movement. All unnecessary level differences should be eliminated. All necessary level differences (e.g. in the WC area) should have a slight slope for ease in negotiating it. Needs of girls and lady teachers must be addressed, including provision for an incinerator for safe disposal of sanitary napkins. All the provisions for inclusiveness are to be based on recommendations made by institutions recognised for the purpose by the Government of India.

8. Address the user tendencies and behaviour: Spaces where an user may be changing clothes or tidying oneself must be adequately screened for privacy. These spaces must not be located near the doorway or be visible from outside. The design may have common walls between the girls and boys toilets, but it must be ensured that the most private spaces are not along the common wall so that even if small punctures are made on them, they do not affect the privacy of these spaces. Urinals for girls must be screened with a door.

Drawing 2:7. Avoid common wall between girls & boys block

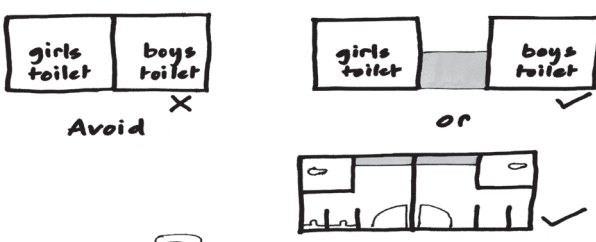

Drawing 2:8. Ensure privacy through location of entrance doors

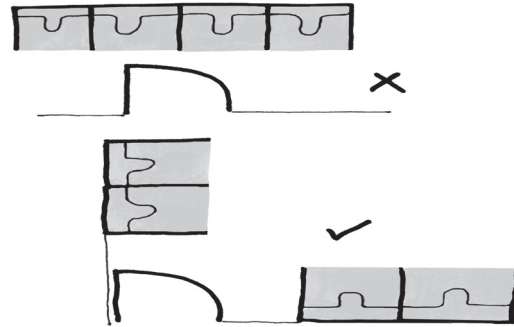

9. Conserve water and its use: All designs use Indian squatting type WC with higher slope (rural pan) that uses less water for flushing. The waste water from hand wash is to be re-circulated in the urinals to wash them and conserve additional water for washing and cleaning.

Drawing 2:9. Recycling of hand wash water

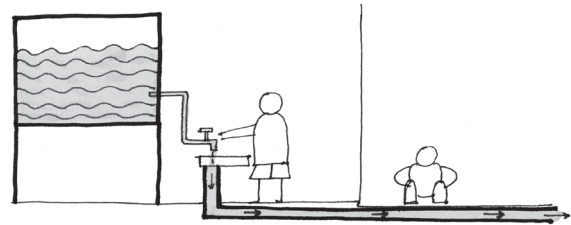

10. Designed and located for low maintenance: Very often the design may seem to be good, but may require high maintenance. This may lead to a high life-cycle cost over a period of time. Hence, the core design, its finish and specifications, must be such that it requires low maintenance. The facilities must be located in a way to make sure they do not stink and remain dry. In case of toilets, adequate slope and its direction must be ensured so that water does not stagnate and floors remain dry.

Drawing 2:10. Small details like slopes in WC area



11. Maximize natural light and ventilation in design for effective hygiene: In an energy-scarce country, it is important that we use naturally available renewable sources of energy to the fullest. It is possible to ensure better hygiene through good natural ventilation and sunlight. The design must ensure adequate natural light and ventilation for proper drying of wet cores (especially the WC and the urinal) and other provisions through the day. This will also minimise the stink and the amount of water used for maintenance. While for each site, the most

Drawing 2:11. Allowing natural sunlight inside

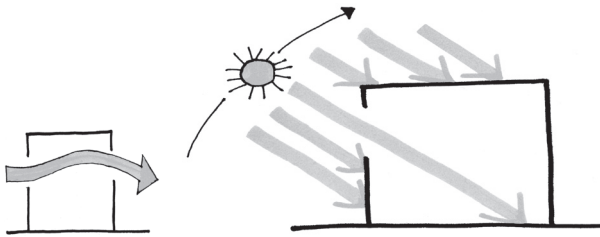

ideal orientation may not be available, the design must provide guidelines for the most satisfactory and acceptable orientation for effective solar passive performance to the supervising engineer.

12. Segregated solid and grey/waste water: The design enables natural segregation of excreta / urine and grey/waste water so that if any recycling technology is available it can be easily integrated in the existing design.

Drawing 2:12. Separate excreta and urine disposal

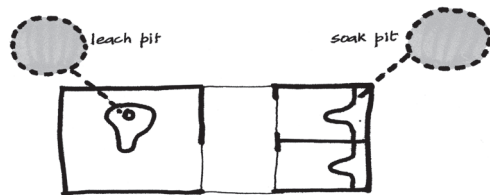

13. Accessible storage: Maintenance of facilities is often an issue due to non-availability of cleaning materials. If space is created for necessary items such as brooms, cleaning reagents, wipers etc. to be stored inside the toilet block and easy access is ensured, toilets will be cleaned and maintained to a great extent.

Drawing 2:13. Provisions kept at child accessible height

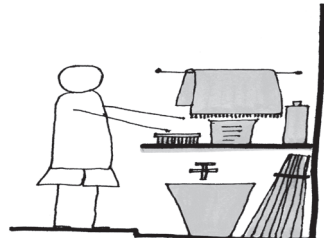

14. Overlap and facilitate multiple use of facilities created: For optimization of resources, the design must attempt to multiply and overlap the uses to the extent possible. Thus, water tank, plumbing pipes, ramps, circulation spaces, must be designed so that they optimize resources. Thus there may be a common ramp, common wash area, common water supply, etc.

Drawing 2:14. Combining provisions to optimize facilities

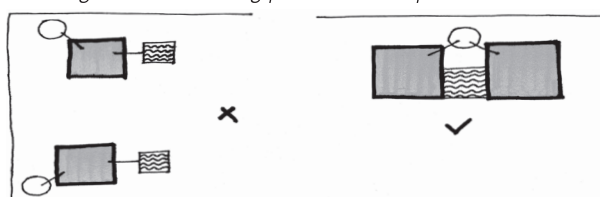

15. Water storage at comfortable height: All designs must have low height water storage for washing and cleaning (base level of water tank to be 1250mm from average ground level if the plinth is 300mm high). This must be done so that simple non-electrical force-lifting methods can be used to fill water in the tanks, even by children.

Drawing 2:15. Force lift pump for easy lifting of water

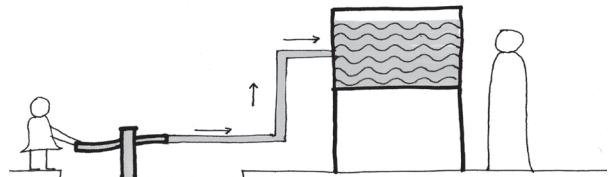

16. Linkage of School Sanitation with Mid Day Meal (MDM) facilities: Today, most schools across the country have MDM facilities. Total sanitation can be achieved only where the mid-day meal is integrated in all daily activities. Thus hygiene during MDM, which includes sanitation of the kitchen or the area where the meal is cooked, hygiene during cooking, cleanliness of the eating area and utensils, washing of hands before and after eating and proper disposal of left-over food and waste water, are of utmost importance. It is important that the facilities are integral to and linked with such facilities for effective overall hygiene as well as optimizing cost of creating amenities in an integral manner. While hand and dish washing facilities for MDM shall be separate, the disposal or recycling of water may be combined with other School Sanitation facilities.

17. Adaptable to different geo-climatic conditions: The design must be flexible to suit different roof types, building materials and different geo-climatic situations. Many areas may be rich in stone, others may be rich in bricks, still others in bamboo, and so on. Climate could vary from warm-humid to hot-dry, or composite. The design layout can also be seen as a generic design which can then be adapted to suit the requirements, potential and limitations of a certain geo-climatic zone.

Drawing 2:16. Plinth wall and roof design as per local geo-climatic conditions

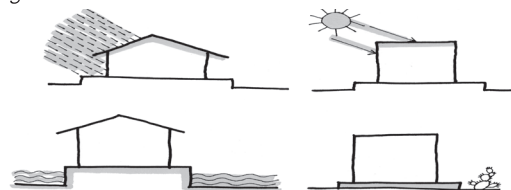

All the new designs developed should be based on these guiding principles. The degree to which they address these principles may vary with each design type.

Section 4

Key Data Required to Design Toilet Blocks

To develop good designs, certain essential data that will help achieve the guiding principles will be needed. This information and data will help in generating good sensitive designs. Following illustrations / data / tables have been especially developed for this document since it presently does not exist in a ready-to-use form elsewhere.

1. *Anthropometric data for design of SSHE facilities:* for developing child accessible provisions in the design.
2. *Different latrine types for typologies of soil conditions and technology choices:* to help determine suitability of latrine type for a given location.
3. *Zone-wise typologies of geo-climatic conditions:* This is a general guideline for responding to diverse geo-climatic situations.
4. *Site layout guidelines of Toilet Block* from climatic considerations
5. Determining the *safe distance of ground water source from leaching/soak pit* of toilet waste disposal.

Anthropometric data for design of SSHE facilities

Very often, the facilities provided in schools are not completely based on the anthropometric data for children and thus the usage by children becomes practically difficult. This data is very useful for a designer/architect/engineer in ensuring that the provisions being proposed in a design are sensitive to the needs of children including those with special needs. Small details like heights of taps or placement of hooks and knobs inside the toilet, grab bars for Children with Special Needs and similar components should be placed after considering the average heights of girls and boys in that age group.

The following illustrations depict dimensions of the facilities and placement of various provisions in various school sanitation designs. These are based on the Indian Council for Medical Research (ICMR) data, UNESCO anthropometrics data for the South-East Asia region and Central Building Research Institute (CBRI), Indian Standard code on human dimensions and guidelines provided by the Ministry of Social Justice and Empowerment under Gol with necessary adaptations made at VINYAS. All dimensions given are in millimetre (mm).

Entrance ramp for CWSN toilet

Drawing 2:17. Section

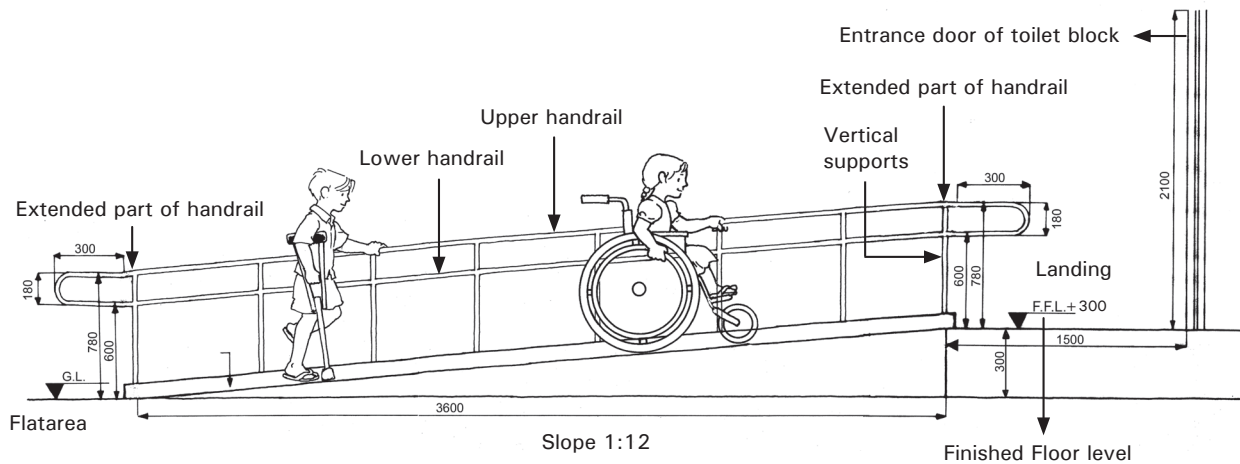

- Accessibility of toilets for all children is critical. Provide a ramp with hand rails and floor skirting with slope and height as shown for comfortable use by children.
- The *heights shown are common for girls as well as boys* hence will be same for girl's / boy's or common toilet blocks. Note that length of ramp is dependent on height of plinth.
- The *ideal recommended slope is 1:18*. However, if the space available is less, then slope of 1:12 (implying that for a plinth height of 300 mm from the ground, the length of the sloping ramp will be = $300 \times 12 = 3600\text{mm}$, as shown) can be taken.
- This slope is provided so that a child can independently propel the wheel chair up without any external help, so the *slope should not be steeper than 1:12*.
- Hence the ramp floor must have *antiskid tiles*.
- The rails must extend horizontally for 300 mm on both sides beyond the sloped area, as also the floor.

Location of the ramp is suggested in some of the designs given in this document. However its location may need site-specific adaptation or modification such that CWSN are required to take the shortest and the simplest route to the facility. Many times CWSN are not able to reach the toilet block itself since the toilet is located such that the approach to the block has inherent obstacles. Hence, accessibility of the toilet from the rest of the school complex should also be ensured.

Entrance door to CWSN toilet block

Drawing 2:18a. Provisions with wheelchair - Elevation

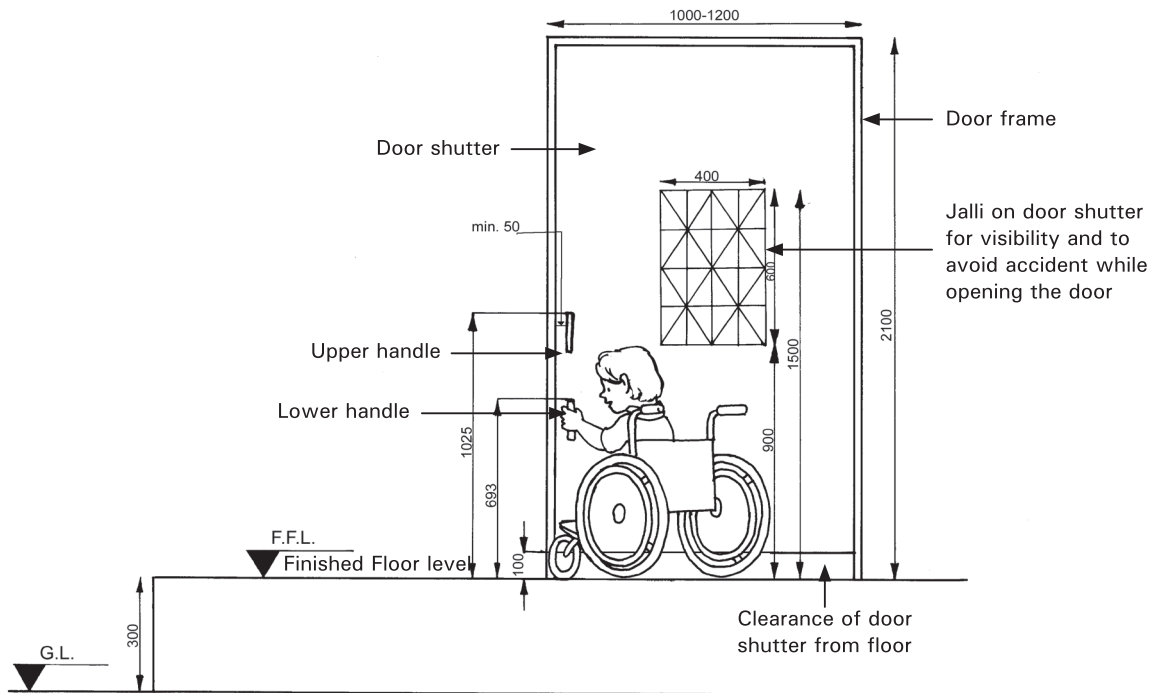

Drawing 2:18b. Provisions with crutches - Elevation

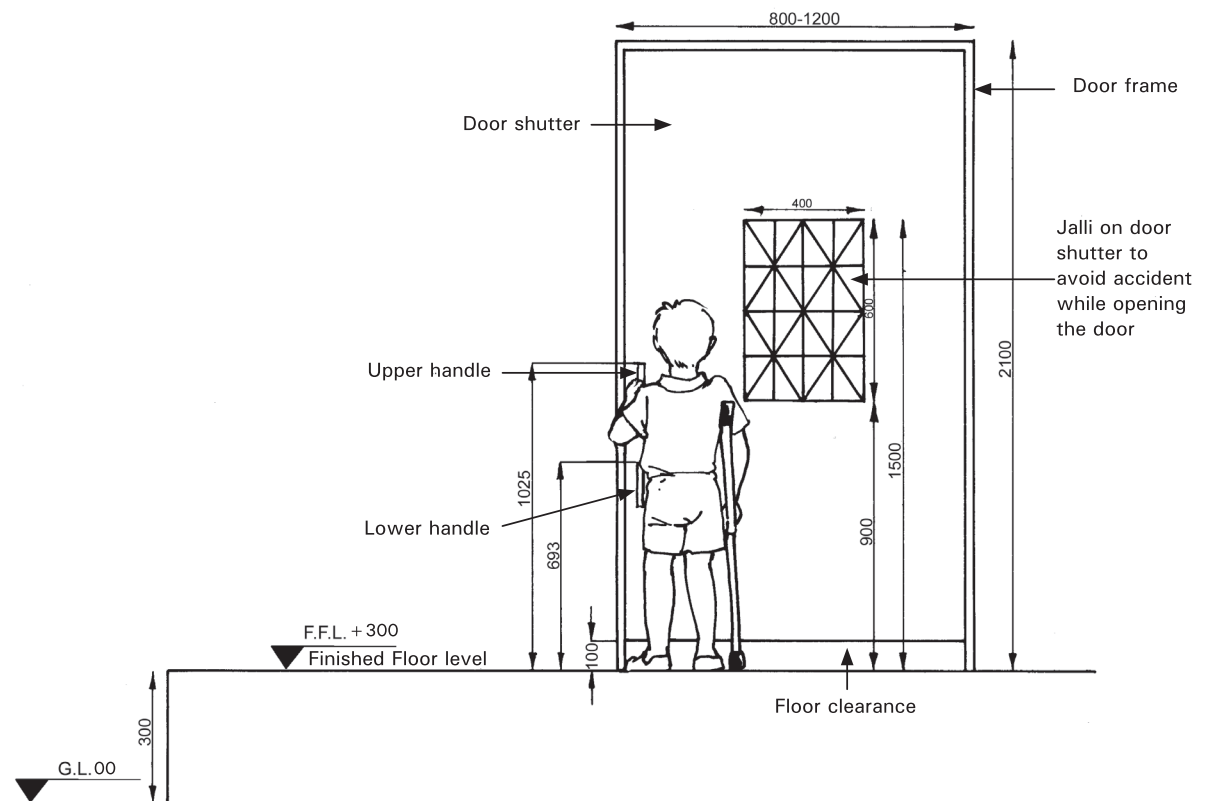

- Door width, opening swing of the door, height, location and design of hardware fittings is also crucial for use by all children (including Children with Special Needs). Some children may be wheelchair users, others may be using crutches. The dimensions shown here take into account these issues of inclusive toilet.
- *The door width is wider for wheelchair to enter.*
- *The average height of hardware provisions like handle, latch, etc. are nearly same for boys and girls. However, two sets of handles are shown so that it is comfortable for all users (including adults) in wheelchair or upright positions.*
- *Door edges may be highlighted with contrasting colour for children with low vision (see colored visuals and drawings of toilet designs given later in this document).*

Provisions in non-inclusive Girl's / Boys' toilet block entrance door

Drawing 2:18c. Elevation

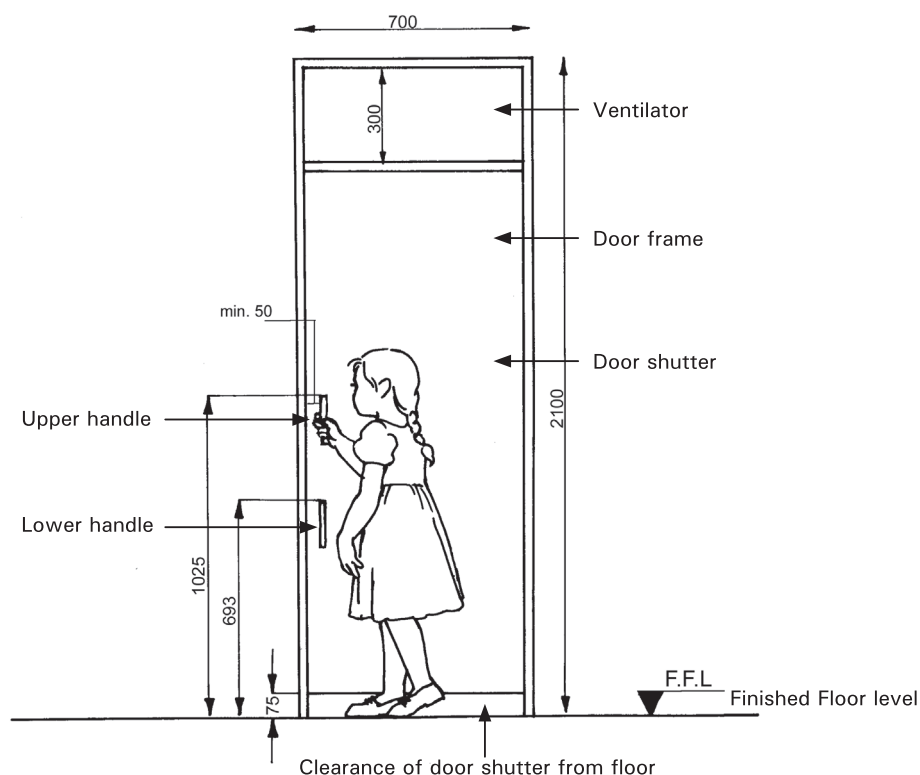

- *In case of non-inclusive toilets (toilets which are not specifically meant for CWSN), the door width may be lesser, as shown, while the hardware and other provisions may be similar to those provided for CWSN.*
- *The average height of hardware provisions like handle, latch, etc. are nearly same for boys and girls. However, two sets of handles are shown so that it is comfortable for all users (including adults).*
- *If available, a single longer handle or a vertical grab bar may also be provided, instead of two handles.*

Girl's Urinal: Provision of door & location of hardware fittings

Drawing 2:19a. Plan

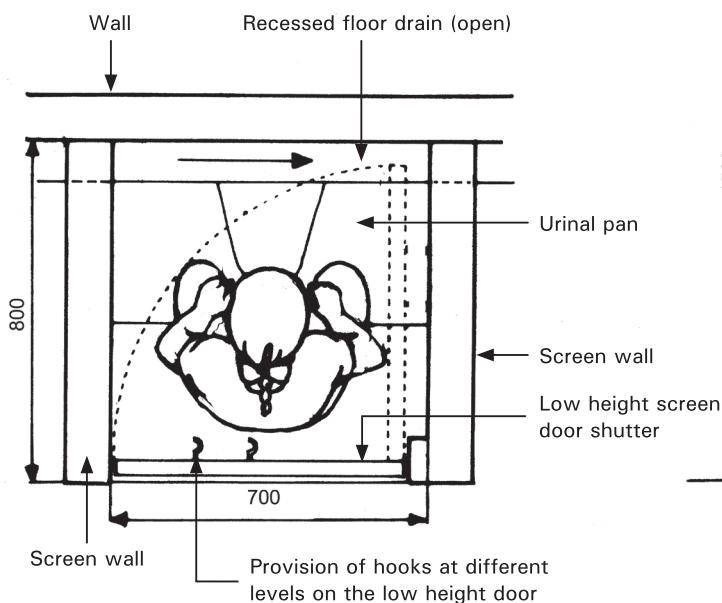

Drawing 2:19b. Section

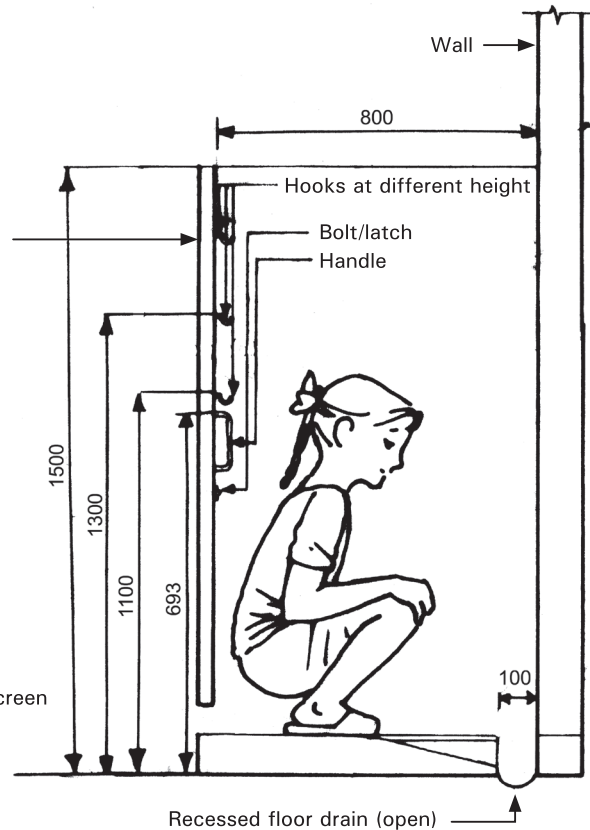

- Urinal design for girls needs a urinal on the floor with *properly sloped impervious floor* towards the drain that carries the urine, and wall with impervious surface like ceramic tiles.
- For privacy, it also needs a *low height door* (1500mm height, as shown) with provisions of hooks to hang any loose clothing if needed to prevent it from soiling on the wet floor.
- The width of 700mm shown in the plan takes into account the clothing that girls usually wear across the country.
- The depth of 800mm takes into account the seating posture and the desired clearance, while economizing the space to the extent possible. It is assumed that adult lady teachers will be using the toilet for urinal purpose.
- The *open drain to be 100mm wide* so that it can be cleaned periodically. *The slope of the floor towards this drain to be ensured.*

Boy's Urinal

Drawing 2:19c. Plan

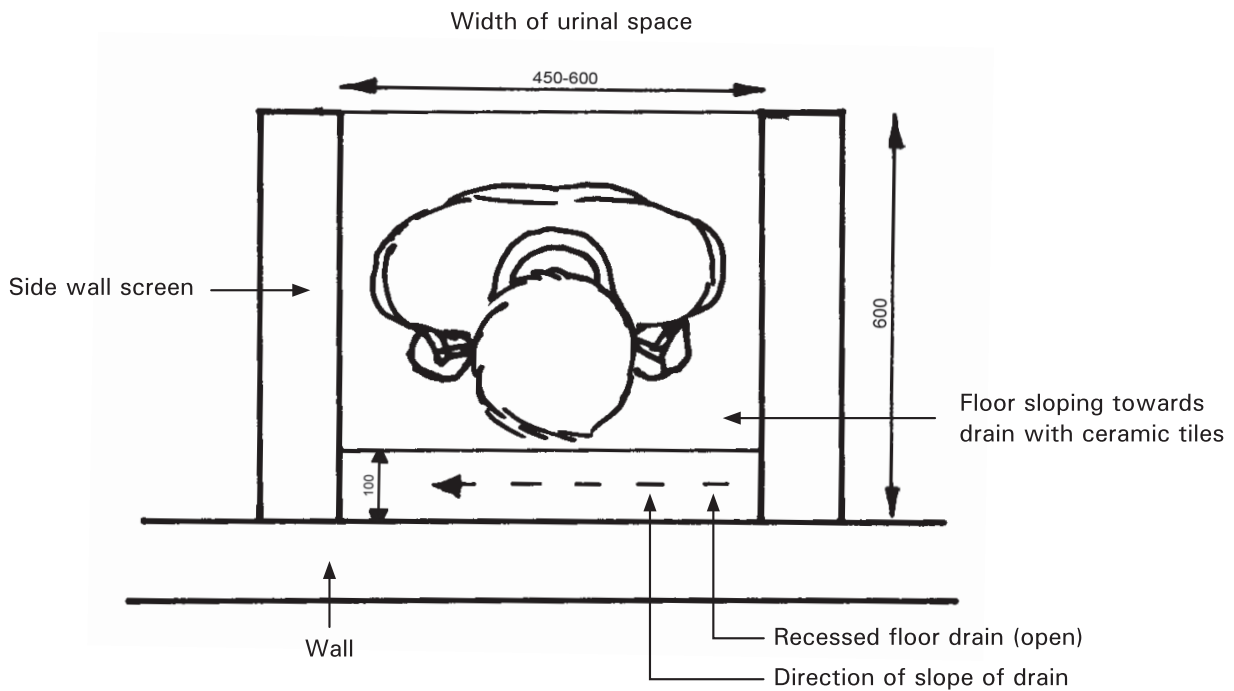

- Urinal design for boys needs a wall with *impervious surface like ceramic tiles* for urinating while standing and a properly sloped impervious floor towards the drain that carries the urine.
- The width shown here (450 to 600mm) is for children (450mm) and adult teachers (600mm). Hence while providing urinals, to economize, while most urinals may be 450mm wide, at least one urinal to be 600mm wide.
- The depth of 600mm shown is applicable for all urinals.
- The open drain to be 100mm wide so that it can be cleaned periodically.

CWSN toilet with stool over Indian squatting pan

Drawing 2:20a. Plan

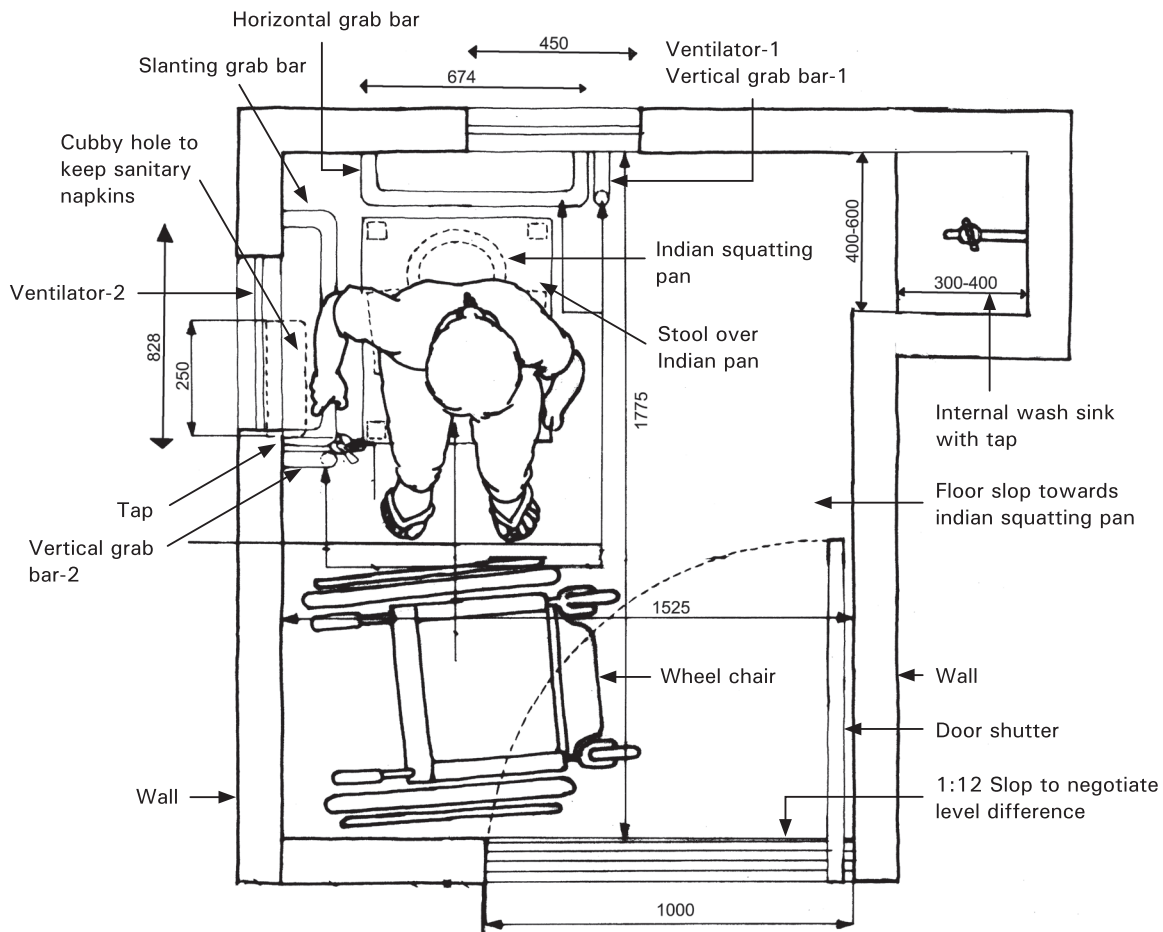

- The toilet has *stool provided over Indian squatting pan* for CWSN. The width of the door (1000mm) takes into account the clearance required for wheelchair, the slope to negotiate the level difference between the inside and outside toilet.
- The internal size of 1525x1775mm takes into account the *space required for turning and transferring* from the wheelchair to the stool.
- Location of internal horizontal and vertical grab bars is shown (with horizontal lengths 828 and 674 mm) to assist the users while using and transferring from the wheelchair to the stool and vice versa.
- The internal *wash sink at appropriate height* is provided for hygiene purposes.

Drawing 2:20b. Section

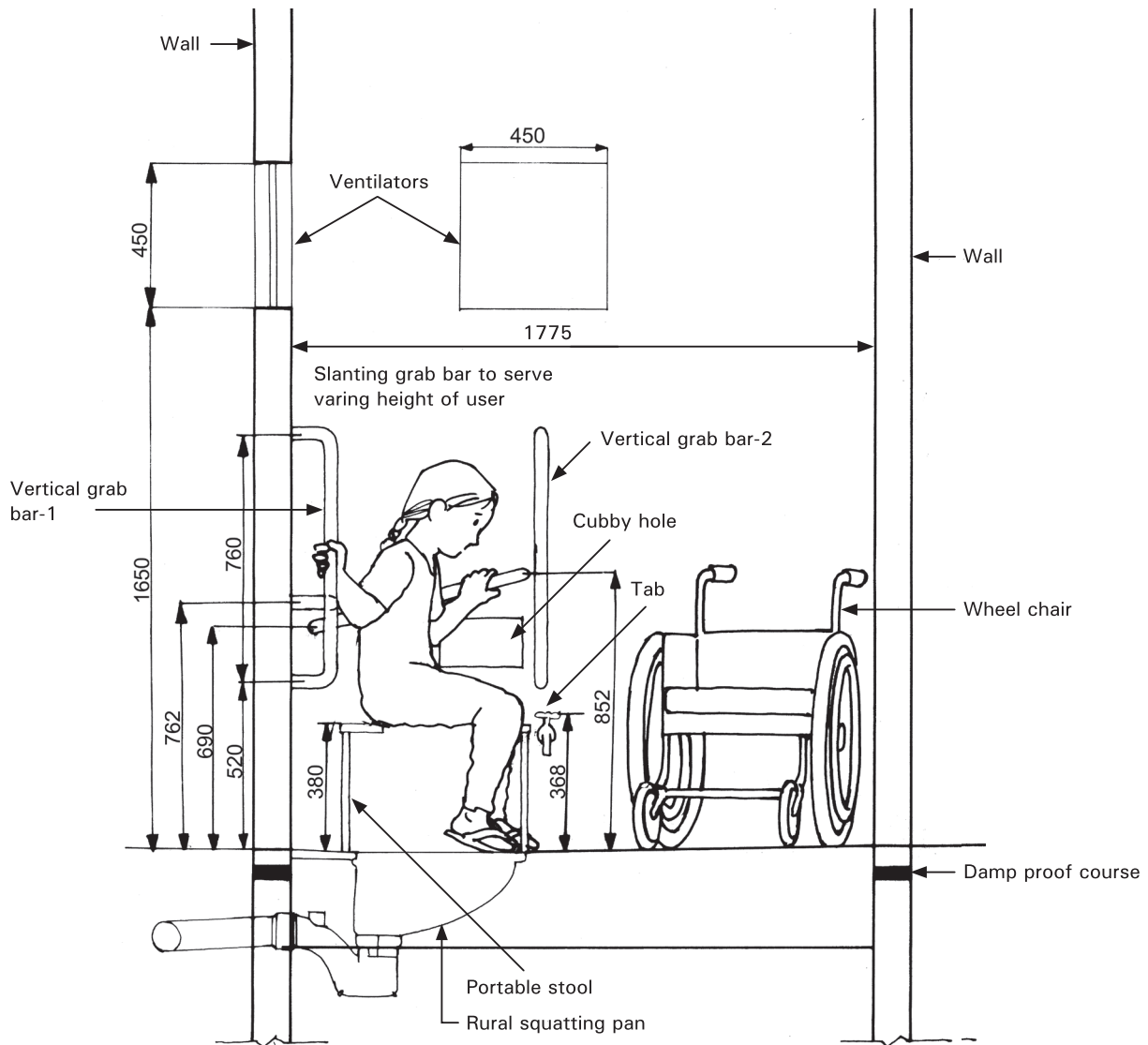

- For girl's toilet, an *incinerator* (not shown) may also be connected through a chute.
- Ventilators must be located such that *natural light and ventilation naturally keeps the space dry*.
- This design is *applicable for girls as well as boys CWSN toilet*. For other details see section Drawing 2:20b.
- The toilet has stool provided over Indian squatting pan for CWSN. Its height 380mm is shown.
- Notice that internal floor slope must be ensured to drain any excess water out from the floor so that there is no accidental slippage.
- The tap must be accessible as shown.

CWSN toilet with Western WC

Drawing 2:21a. Plan

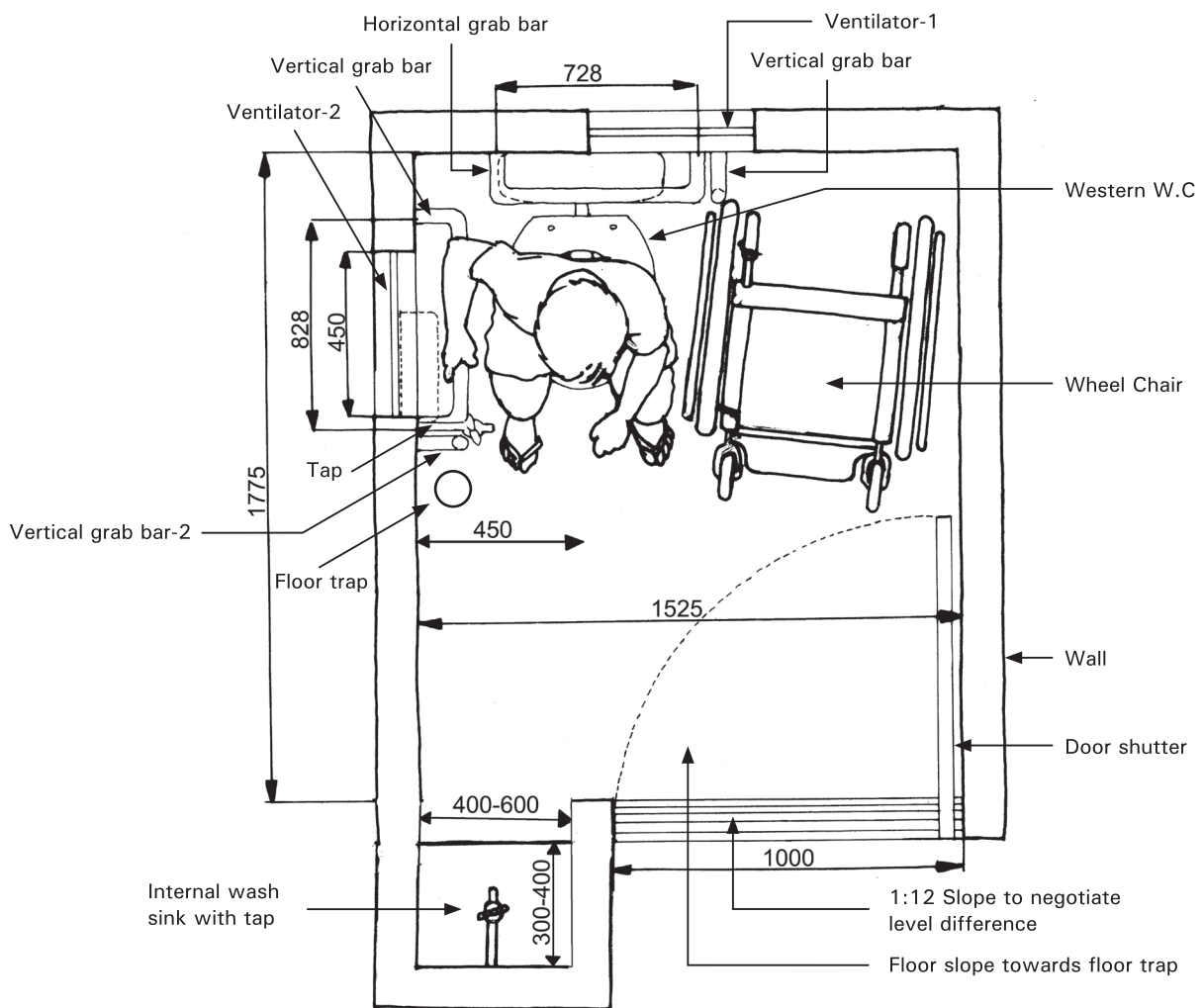

- The toilet has *Western WC for CWSN*. The width of the door (1000mm) takes into account the clearance required for wheelchair, the slope to negotiate the level difference between the inside and outside toilet.
- The internal size of 1525x1775mm takes into account the space required for turning and transferring from the wheelchair to the stool.
- Location of internal horizontal and vertical grab bars is shown (with horizontal lengths 828 and 728 mm) to assist the users while using and transferring from the wheelchair to the seat and vice versa.
- The internal wash sink at appropriate height is provided for hygiene purposes. For girl's toilet, an incinerator (not shown) may also be connected through a chute.

Drawing 2:21b. Section

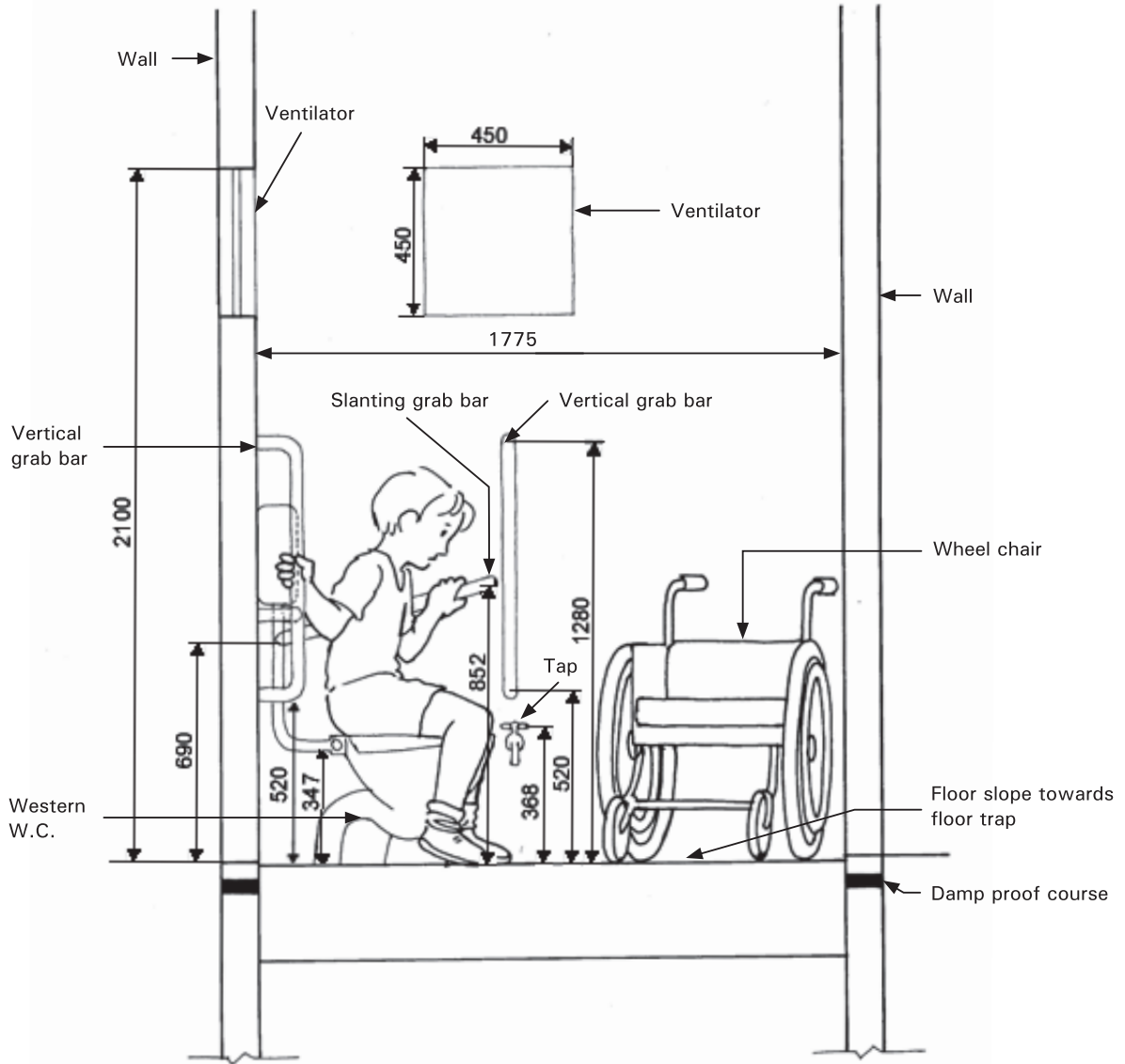

- Ventilators must be located such that natural light and ventilation naturally keeps the space dry.
- This design is applicable for girls as well as boys CWSN toilet. For other details see section Drawing 2:21b.
- Notice that in case of western WC, internal floor slope must be ensured towards a floor trap to drain any excess water out from the floor so that there is no accidental slippage.
- The tap must be accessible as shown. Location of internal horizontal, vertical and slanting grab bars are shown to assist the users while using and transferring from the wheelchair to the seat and vice versa.

Girl's toilet with Indian squatting pan and provision of incinerator

Drawing 2:22a. Plan

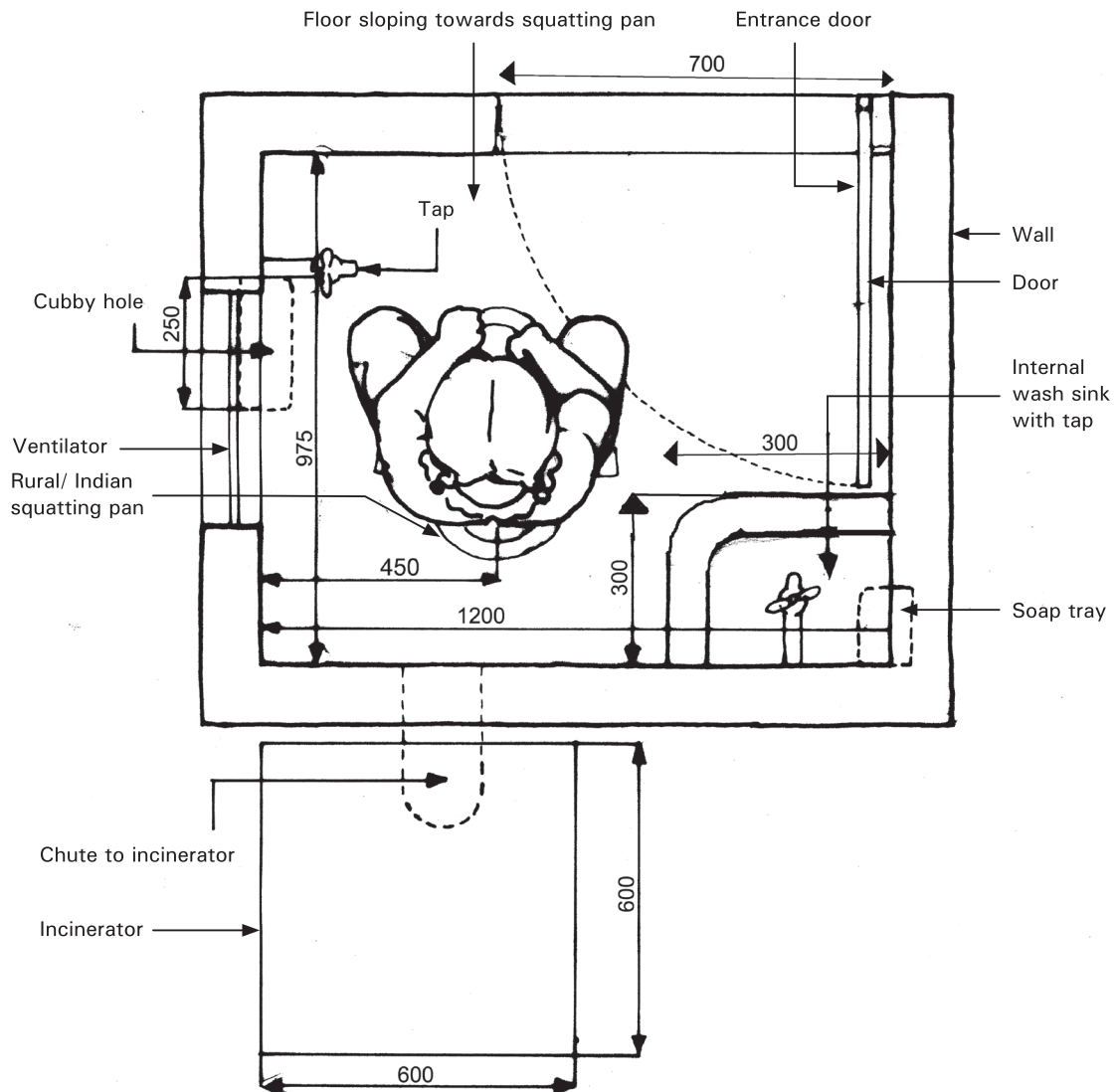

- Toilet designs for girls need special attention. Internal clear size of 1200 x 975mm takes into account the specific needs of the girls.
- There must be a small child accessible *niche* to keep new sanitary napkins.
- There must be a *connection to an external incinerator* through a child accessible chute to later incinerate the sanitary napkins.
- The location of incinerator is suggestive and can be adapted to suit different site situations.
- It must be ensured that it is directly accessible through a chute from at least one of the girl's toilets.
- Provision of an internal hand wash is desirable from hygiene perspective. This must be separate from the tap located near the toilet seat.

Drawing 2:22b. Section

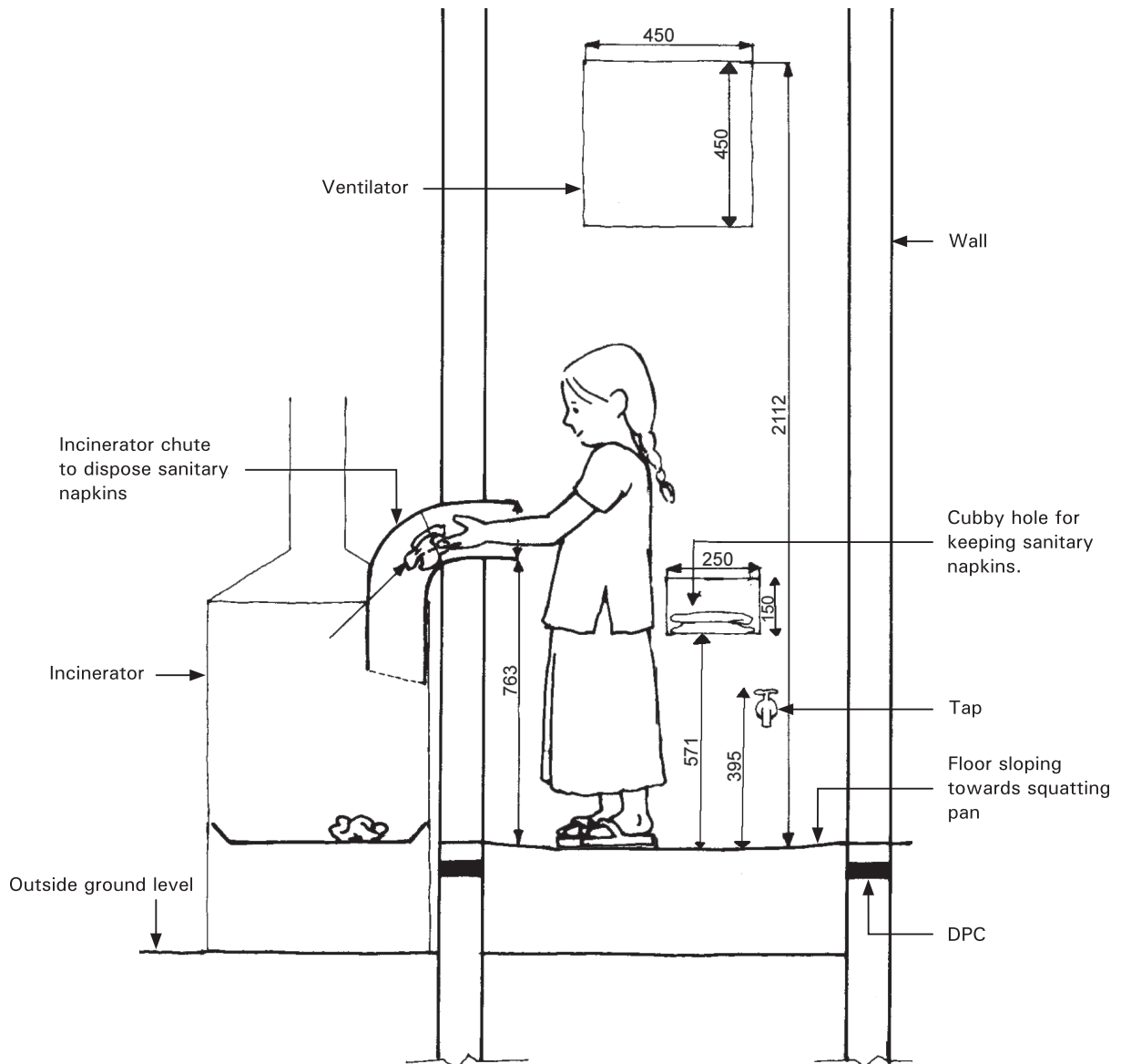

- Ventilators must be located such that natural light and ventilation naturally keeps the space dry. See Drawing 2:22b for more details.
- Toilet designs for girls need special attention. There must be a small child accessible niche to keep new sanitary napkins.
- Also the floor slope must be ensured such that there is no stagnated water or dampness. See Drawing 2:22a for more details.

Boy's toilet with Indian squatting pan

Drawing 2:23. Plan

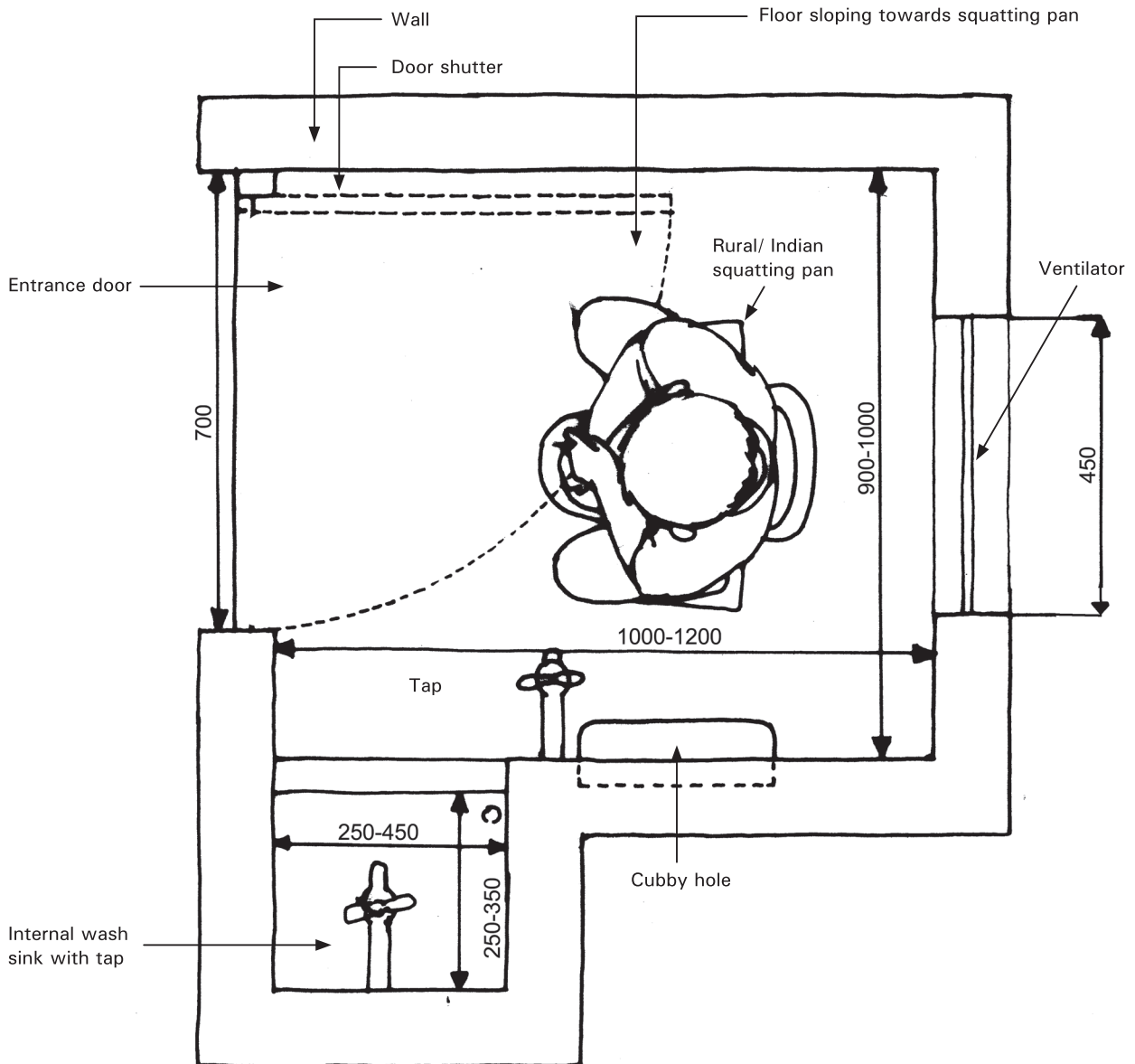

- Internal clear size of 1000mm minimum to 1200mm maximum in depth and 900mm to 1000mm is suggested.
- Provision of an *internal hand wash* is desirable from hygiene perspective. This must be separate from the tap located near the toilet seat.
- Ventilators must be located such that natural light and ventilation naturally keeps the space dry.

Door in boy's & girl's toilet

Drawing 2:24a. Section

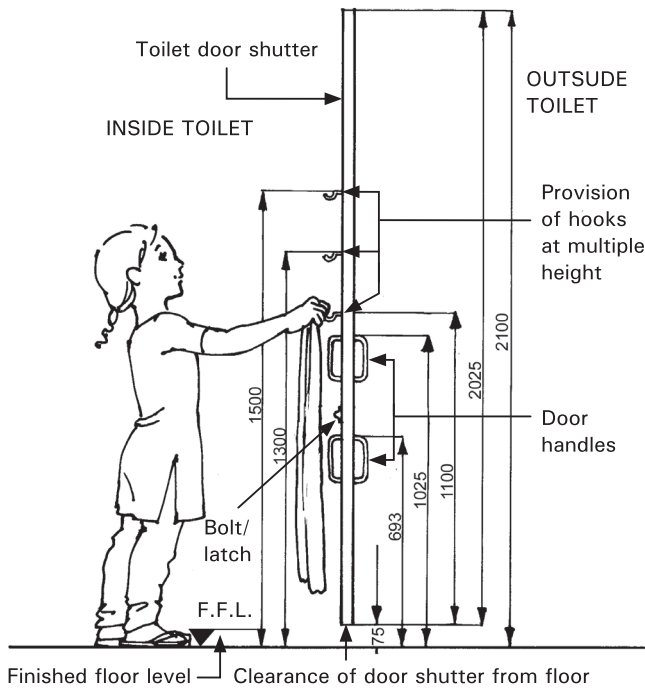

Drawing 2:24b. Section

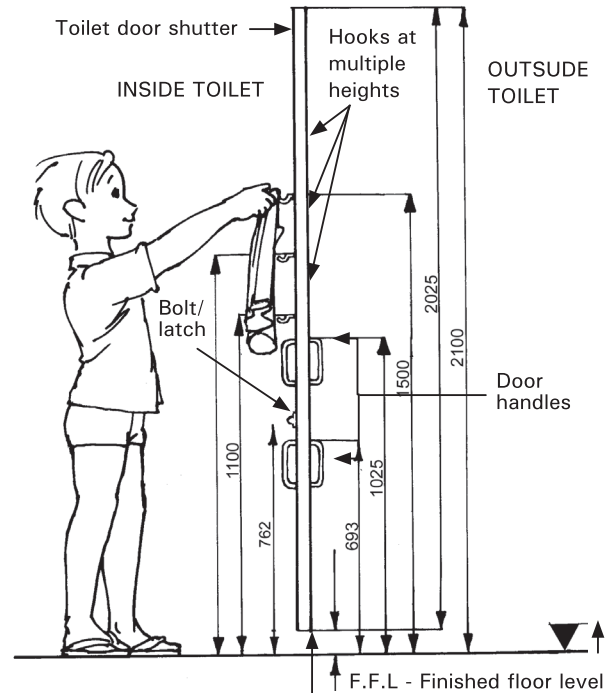

- The doors for urinals and toilets for boys and girls must have *hooks at different heights to hang loose clothes / undergarments* for different heights of children (given at heights 1100, 1300 and 1500mm from the floor).
- The handles and securing bolt must also be at *child accessible height*.
- The *door to have clearance of at least 75mm from floor* for longer life as shown. Typically door bottoms get damaged due to continuous dampness / splash of water. This clearance will avoid the damage.
- *Two sets of handles* are shown (at 693 and 1025mm height from the floor) so that it is comfortable for all users (including adults).
- If available, a single longer handle or a vertical garb bar may also be provided, instead of two handles.

Child using washbasin for washing hands

Drawing 2:25a. Plan

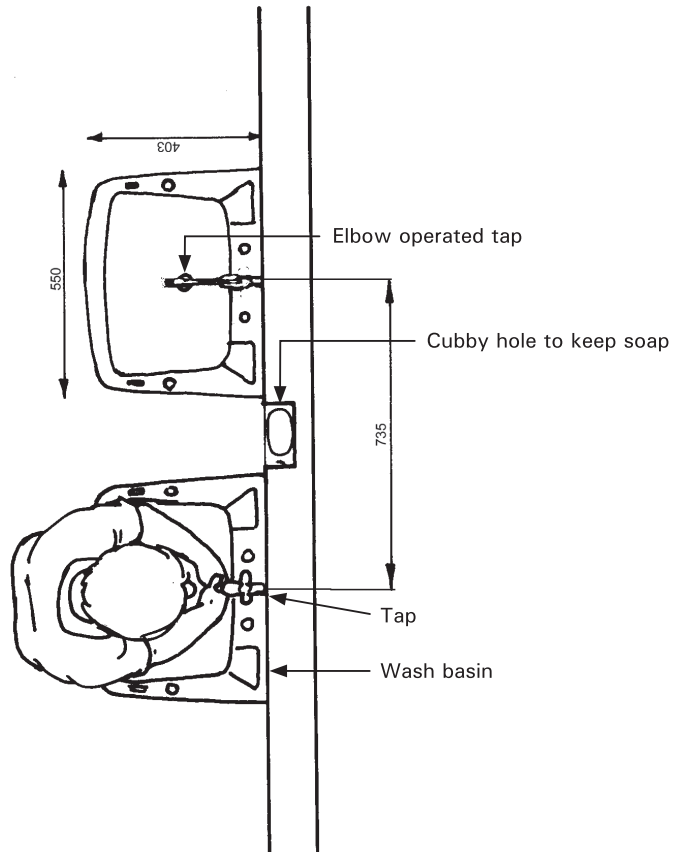

Drawing 2:25b. Section

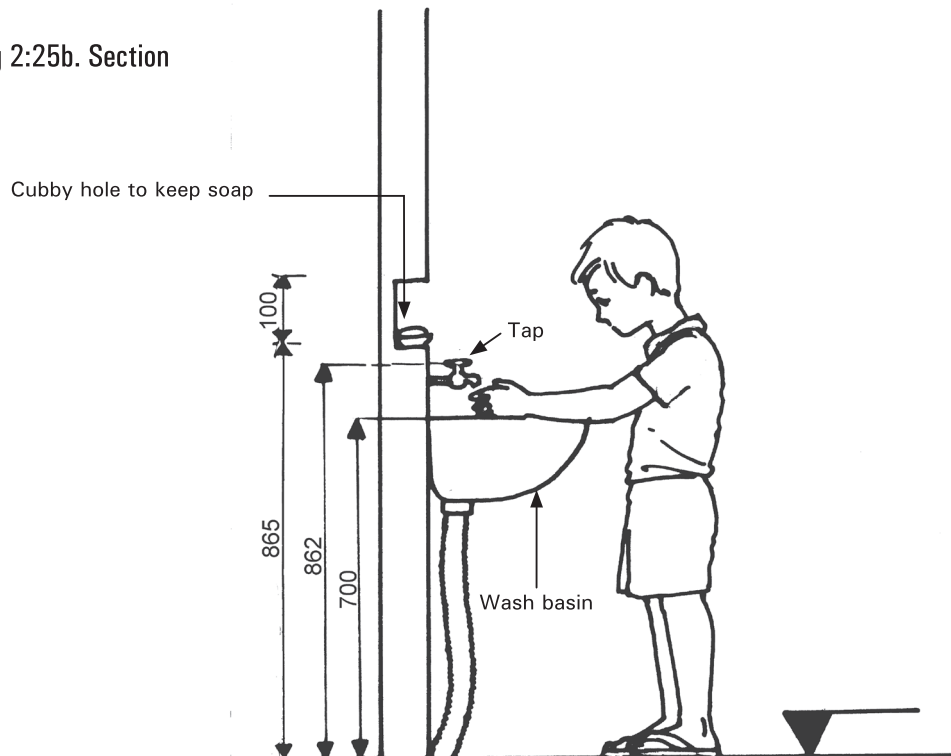

Drawing 2:25c. Elevation

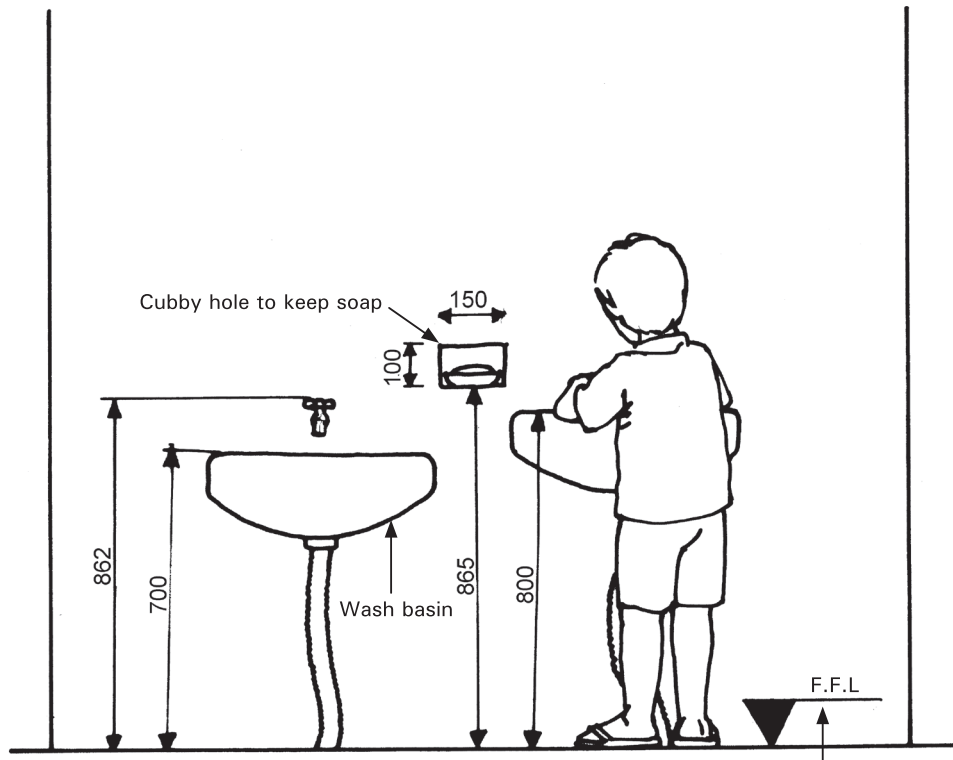

- Hand washing facility must be placed at *child accessible height*. This will also avoid wastage of precious water.
- Since children of different age group in the school may have different heights, the washbasin and taps may not be at the same height uniformly. Hence variable heights may be provided.
- Provision to keep *accessible soap nearby* is essential for hygiene purposes, as shown. This is applicable for wash basins, which can be located at different heights.
- The three drawings shown here clearly illustrate the horizontal spacing between taps (see plan) and the location of soap tray, the vertical heights for individual washbasins, taps and soap tray (see section and elevation).
- This helps in adequately planning and detailing the facility.

Wall integrated sink for washing hands

Drawing 2:26a. Plan

Typically, the sinks integrated with wall may be more compact and economical in the long run as compared to wash basins. The spacing between the taps (450mm) is less here and the depth (300-375mm) is also less as compared to wash basins.

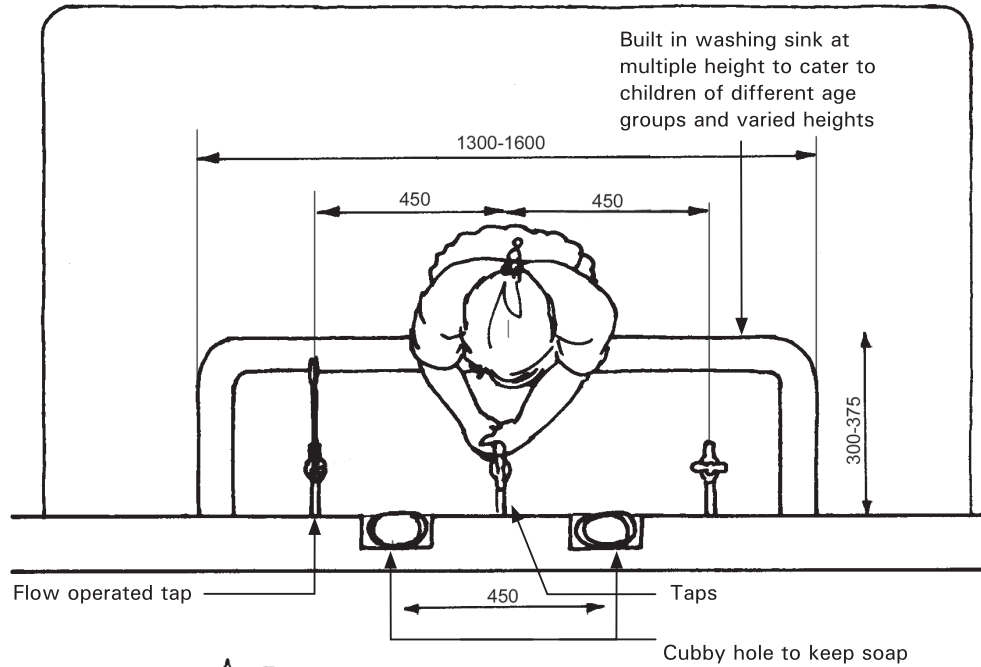

Drawing 2:26b. Section

Taps at multiple height shown here (700, 785, 870mm from the floor where children stand) make the facility accessible and usable to more children and also helps in avoiding wastage of water.

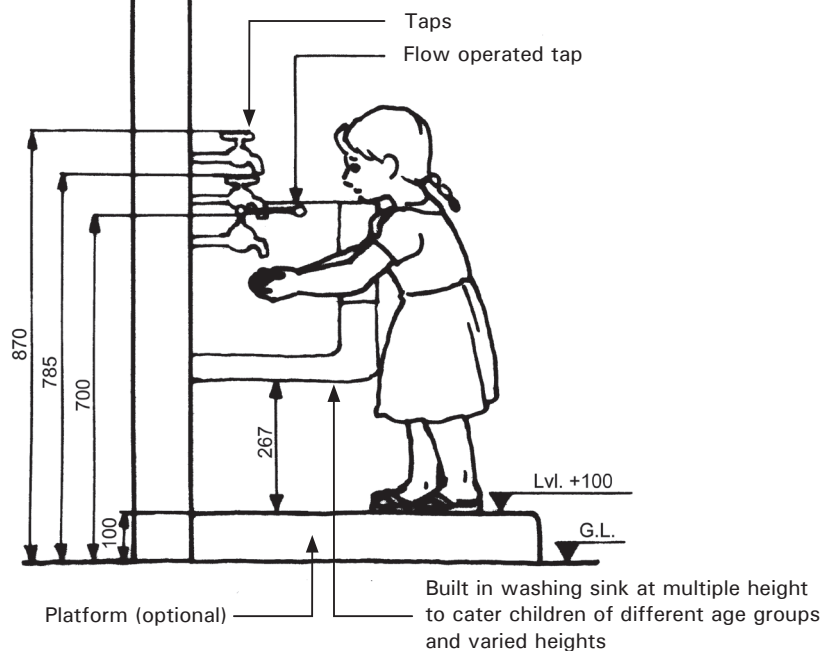

Wall integrated sloping sink for washing hands

Drawing 2:26c. Elevation

It is not just the taps, but also the water that can conveniently drain off the sloping sink. The lower height of the sink should not be less than 267mm for the lower tap and about 467mm for the higher tap.

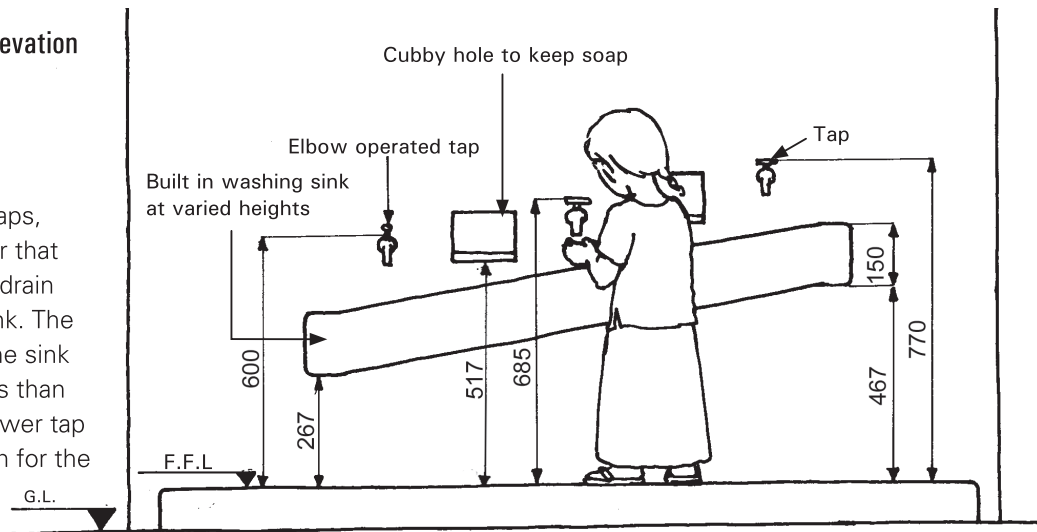

Wall integrated stepped sink for washing hands

Drawing 2:26d. Elevation

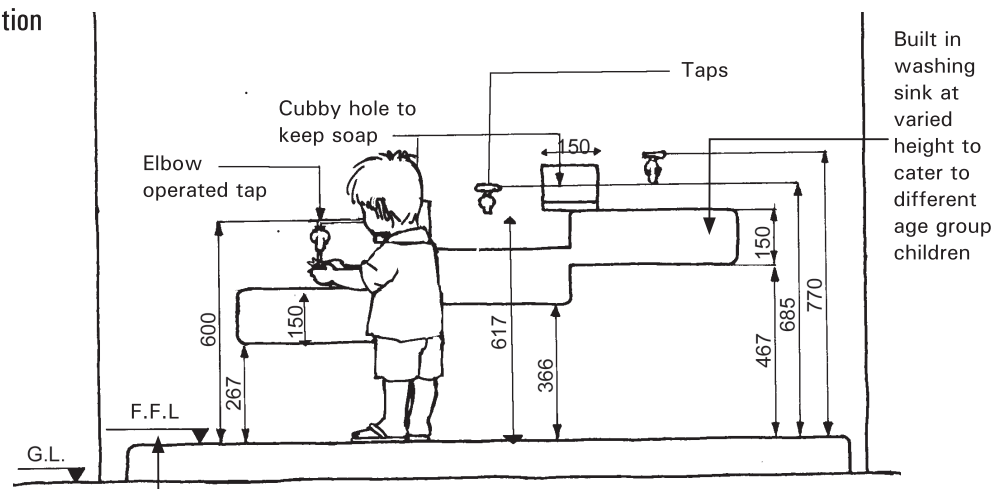

It is not just the taps, but also the water that can conveniently drain off the stepped sink. The lower height of the sink should not be less than 267mm for the lower tap and about 467mm for the higher tap.

- Hand washing facility must be placed at child accessible height. This will also avoid wastage of precious water.
- Since children of different age group in the school may have different heights, the sink and taps may not be at the same height uniformly. Hence variable heights may be provided.
- Provision to keep accessible soap nearby is essential for hygiene purposes, as shown. This is applicable for long sinks integrated with the walls which can be designed with variable heights (sloping as well as stepped).
- The three drawings shown here clearly illustrate the horizontal spacing between taps (see plan) and the location of soap tray, the vertical heights for sinks, taps and soap tray (see section and elevation). This helps in adequately planning and detailing the facility.

Provision for using earthen pots for drinking water

Drawing 2:27a. Elevation

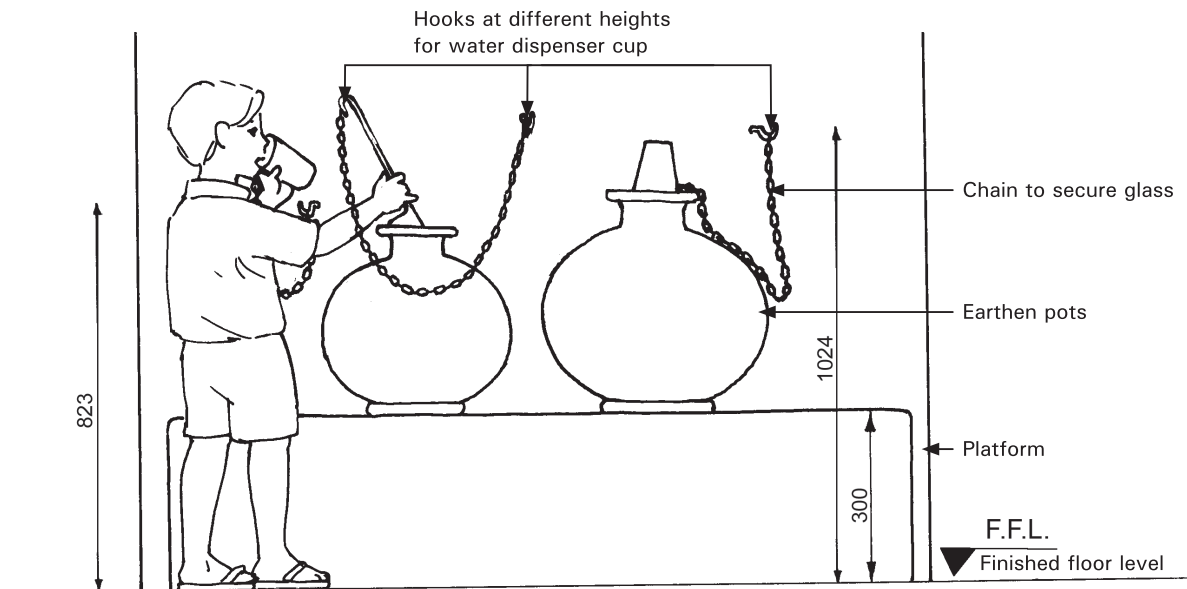

- Earthen pots for drinking water to be placed at comfortable height for children to use as well as to keep them clean.
- The surface on which pots are kept must be sloping such that any spillover water does not fall on the users.
- The scoop and the glass may be secured with a chord from the point of inclusiveness, so that in case these provisions fall, they do not hurt and can be pulled back with the securing chord by a child, especially CWSN, without bending.

Drawing 2:27b. Section

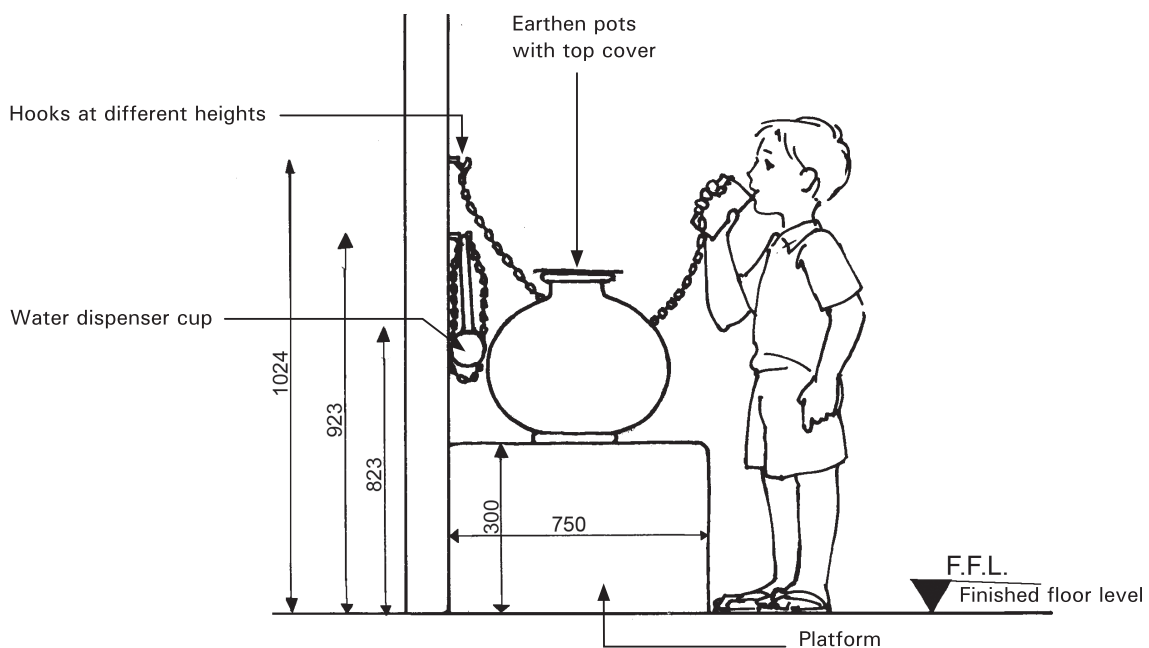

Provision for drinking water using filter / tank / tap

Drawing 2:28. Section & Elevation

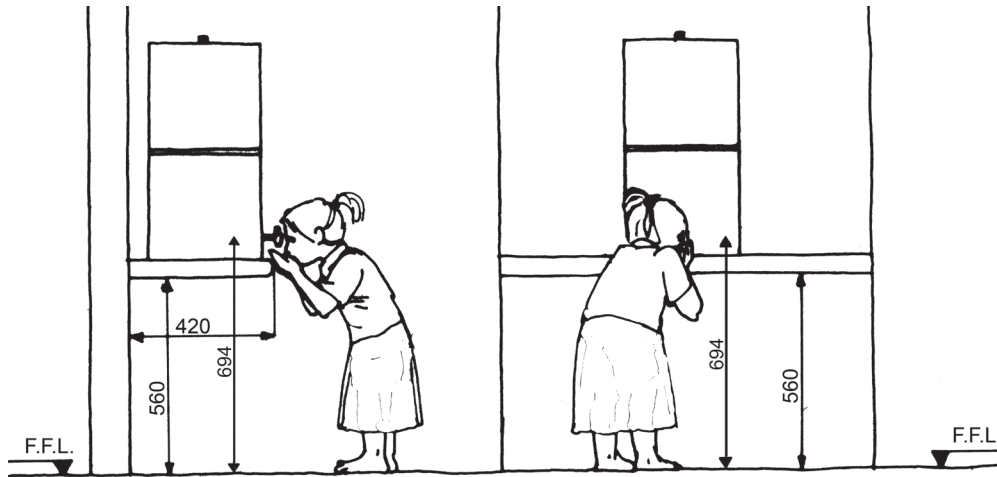

If the water filter or any other such provision with tap (other than fixed tank) is given, this detail may be used. It must allow the place to keep the glass for drinking water. The filter may be kept on platform at a height 560mm, and its minimum safe width will be 420mm.

Storage to be provided in the toilet blocks

Drawing 2:29a. Section

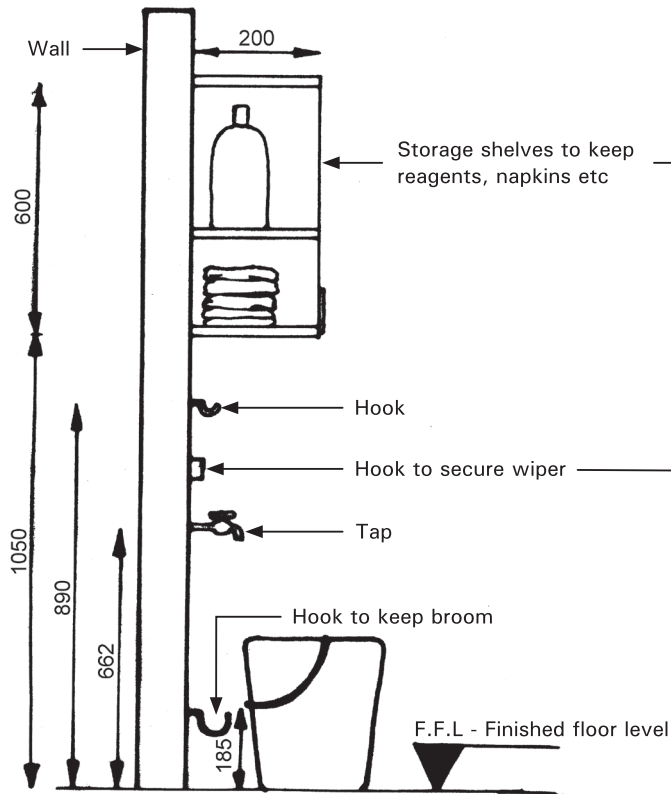

Drawing 2:29b. Elevation

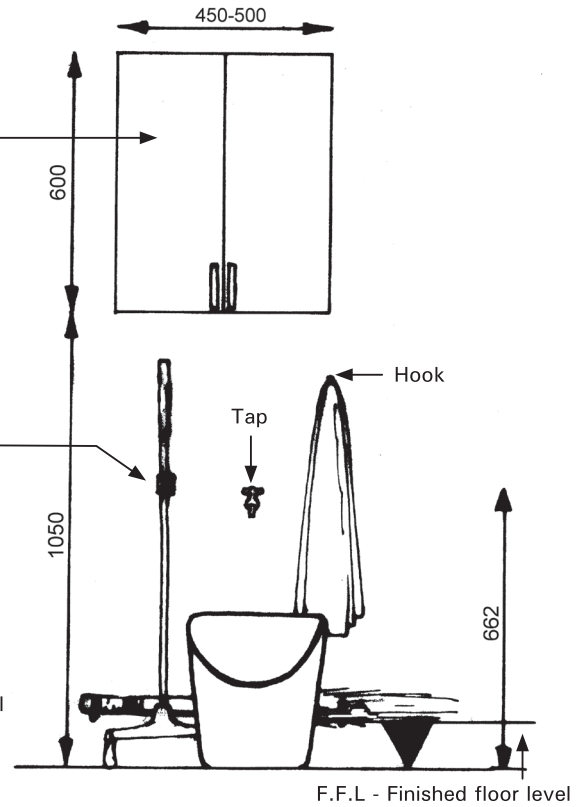

- For effective and timely cleaning of toilets, it is important to keep the *cleaning reagents, broom, wiper, bucket, etc. ready and accessible for the cleaner*, within the vicinity of the toilet block itself.
- Appropriate hooks, storage shelves, tap etc. to be provided for this purpose. These are shown here.

1. Different latrine types for typologies of soil conditions and technology choices

The selection of toilet technology will depend upon the soil condition. This table is useful to identify the possible technology options for toilets for different types of soils.

Table 2.4

Latrine type	Direct single pit latrine without pour-flush	Direct double pit latrine without pour-flush	Offset single pit latrine with pour-flush	Offset double pit latrine with pour-flush	Solar heated single-vault ecological latrine with urine separation	Double-vault ecological latrine with urine separation	Urinal
Suitable for high ground water table	Yes, if raised	Yes, if raised	Yes, if raised and with soak away	Yes, if raised and with soak away	Yes	Yes	Yes
Suitable for areas prone to floods, tidal floods, or flushes	Yes, if raised	Yes, if raised	Yes, if raised	Yes, if raised	Yes	Yes	Yes, if raised
Suitable for loose soils	Yes, if fully lined	Yes, if fully lined	Yes, if fully lined	Yes, if fully lined	Yes	Yes	Yes
Suitable for soils of low permeability	Not for clay soils	Not for clay soils	Yes, with soak away	Yes, with soak away	Yes	Yes	Yes
Water requirement	No	No	Yes	Yes	No	No	Yes, a bit
Ease of construction	Easy	Easy	Easy	Fairly easy	Easy	Easy	Easy
Ease of maintenance	Easy	Easy	Easy	Easy	Difficult	Difficult	Easy
Remarks	Sludge unsafe	Sludge unsafe	Safe sludge	Safe sludge	Safe dehydrated material	Safe dehydrated material	

Source: IRC Technical Paper Series 39 [School Sanitation and Hygiene Education – India]

2. Climatic zones in India and design parameters for toilets

India is a diverse country with diverse climatic zones (shown as zone I to VI here). Based on peculiarities of geo-climatic aspects in each zone, certain suggestions are made in this table for making provisions in the buildings and toilets. This will help in making buildings that are sensitive to the climate and geology of a particular zone.

Table 2:5

S.No.	Parameters	Zone I West Coastal Tropical	Zone II East Coastal Tropical	Zone III Peninsular Plains	Zone IV Gangetic Plains	Zone V Desert Areas	Zone VI Eastern Hill Areas
1	Site	Good rain water drainage essential	Good rain water drainage essential	Good rain water drainage essential	Good rain water drainage very essential in view of the flat terrain and possibility of water stagnation.	Nothing specially required.	Good rain water drainage essential
2	Layout	Building to be on the E-W to NE-SW axis to reduce solar heat gains and improve wind movements.	Building to be on E-W axis to reduce solar heat gains.	Building on E-W axis to reduce solar heat gains in summer and most part of winter.	Building axis to be East-West to avoid heat gains in summer and receive the same in winter. Location of rooms to be judiciously determined.	Building axis East-West to avoid solar heat gain in summer and receive it in winter. Compact planning to avoid exposure to sun.	Building axis to be East-West to avoid heat gains in summer and receive the same in winter.
3	Air-movement	Good arrangements for cross ventilation.	Single banked modules with good arrangement for cross ventilation.	Single banked modules for good cross ventilation.	Open spacing desirable to take advantage of external air motion for cross ventilation just to fit. Excessive air changes in summer or winter brings in heat or cold respectively from outside.	Not critical but desirable and hence compact planning needed.	Open spacing desirable to take advantage of external air motion for cross ventilation just to fit.
4	Opening	25% of floor area and up to a maximum of 30% for ventilation, air movement and daylighting, low sill heights, windows/ventilators horizontal.	Upto 25% of floor area and upto 30% for ventilation and daylighting.	Upto 25% of floor area for ventilation, air motion and daylighting. Winter sunshine may be desirable.	Minimum 25% and upto 30% of floor area for ventilation and daylighting.	Minimum 12% of floor area	Upto 25% of floor area and upto 30% for ventilation and daylighting.

Contd....

S.No.	Parameters	Zone I West Coastal Tropical	Zone II East Coastal Tropical	Zone III Peninsular Plains	Zone IV Gangetic Plains	Zone V Desert Areas	Zone VI Eastern Hill Areas
5	Roofs	May be light weight but should be insulative. Protection against heavy rainfall necessary.	Light weight with short time lags may be sufficient. Design for moderate rains.	Light weight insulative or medium heavy with short time lags may be sufficient. Design for moderate rains. False ceiling and attic ventilation may be useful. Northern positions may need heavy roofs also.	Roofs should be designed for moderate rains. May be white washed for additional comfort, just before onset of summer, to reduce heat gains.	Roofs can be flat. May be white washed for additional comfort, just before onset of summer, to reduce heat gains.	May be light weight but should be insulative. Protection against heavy rainfall necessary.
6	External walls	Light weight, and thin, if possible, short time lag for heat transfer. Light external colours. Wall rain protected.	Light weight and thin, if possible with short time lags for heat insulation. Light external colours, damp proofed.	Light weight with short time lags will suffice. Local conditions may dictate heavy walls. Light colour on walls.	Careful consideration should be given to plan internal occupancy during hot summer months.	May be thick with long heat transfer lag time.	Light weight if possible with short time lags for heat insulation. Light external colours, damp proofed.

Source : Based on CBRI data; adapted for use on toilet designs by VINYAS.

3. Site layout guidelines of Toilet Block from climatic considerations

a) Wind penetration for natural ventilation

For toilets to function efficiently without consuming any electrical or mechanical energy, they should be naturally ventilated and have solar passive designs to naturally disinfect and dry the spaces. Very often, the design itself may be good, but its location and orientation on a site may not be appropriate to obtain its maximum potential.

To have the best natural ventilation and penetration of sunlight, the following information will be useful for site planning, orientation and in laying out the toilet block. For effective natural ventilation, the toilet block should be at a distance of five times the height of the building that blocks the wind from the windward side. This will be useful for the toilet designs given at the end of this document.

It may also be noted that this distance of 5X is the minimum and can be more, if required for the penetration of sunlight (see table 1 with Sun penetration for natural light and hygiene)

Drawing 2:30.

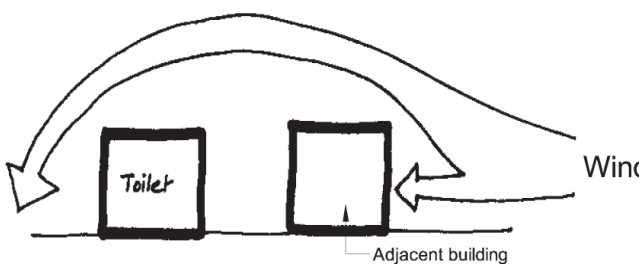

Toilet block should not fall in the wind shadow zone of adjacent block.

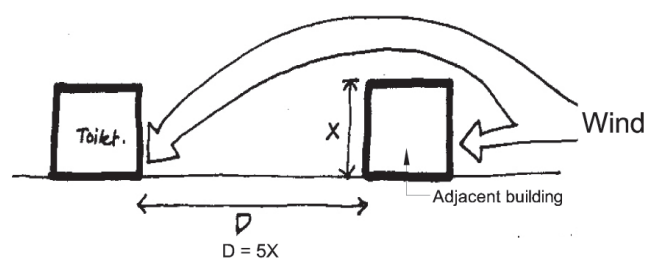

If the toilet block is at a distance 'D' from the adjacent building (which lies in path of prevalent wind direction) then it can avoid falling in the wind shadow zone of the adjacent building.

Drawing 2:31. Placement of building for Wind penetration

1. Height of the surrounding building is assumed as 'X'. This height is inclusive of plinth, building and parapet.
2. The distances are from toilet block and not from ramp / landing areas.

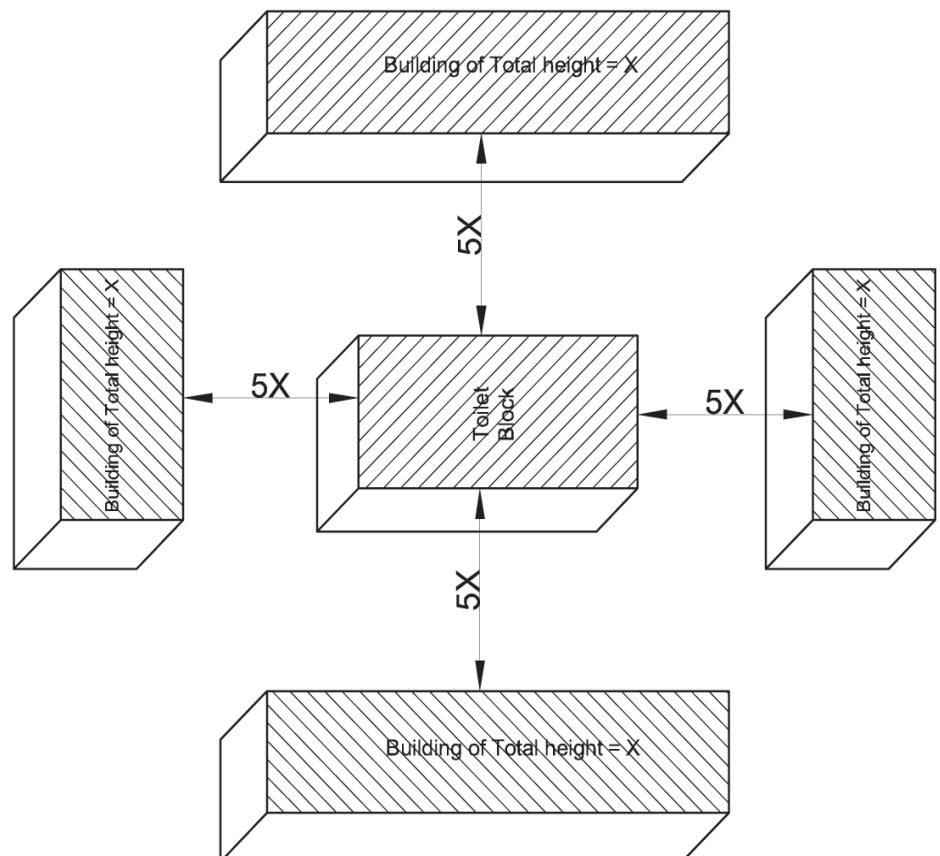

b) Sun penetration for natural light and hygiene

To ensure the penetration of direct sunlight in the toilets, the best, satisfactory and acceptable orientations for each design option suggested in this document has been given. However, this penetration is also governed by the buildings that surround the toilets – existing classrooms, toilets, their effective height, etc. The penetration of the sun is also governed by the geographical location and the corresponding angle of the sun (which is different at different latitudes across the country). To understand this, first locate your site on the map of India and find the nearest latitude (the horizontal lines, of 12° north, 20° north, 24° north, 28°

north or 36° north). It may be noted that all locations along latitude will have similar penetration of sunlight. Then, using the data on latitude see the table on the next page to determine the minimum distance/clearance needed from the toilet of a nearby building on the site for effective sun penetration. Use this distance data to plan the toilet location and orientation.

For effective sunlight penetration, refer table 1 in the next page on Sun penetration for natural light and hygiene. Here determining and maintaining the clearances A, B, C is important. Let us understand these clearances. Clearance A is to be left between the toilet block and the nearby building on the eastern

side. Suppose, the site is located in southern India, refer the suggestions made for 12° north column. Here clearance A=8.7meters will ensure penetration of sun from 7.30am if the ventilator is on eastern side in the toilet. If A=2.1meters, it will penetrate from 10.30am onwards. Similarly, clearance B is to be left between the toilet block and the building on the southern side. On the same site if clearance B=1.56meters, the sun will penetrate from 12.00pm onwards if the ventilator is on the southern side. This will also depend on the location and size of the sunshade / roof overhang if provided over the ventilator. Clearance C is to be left between the toilet block and the nearby building on the western side. For the above site, if clearance C=3.69meters, the sun will penetrate from 3.00pm onwards if there is a ventilator opening on the western side. In a particular site only one or two such clearances may be needed depending upon the location of the existing building and the proposed toilet block.



Drawing 2:32. Sun penetration of natural light

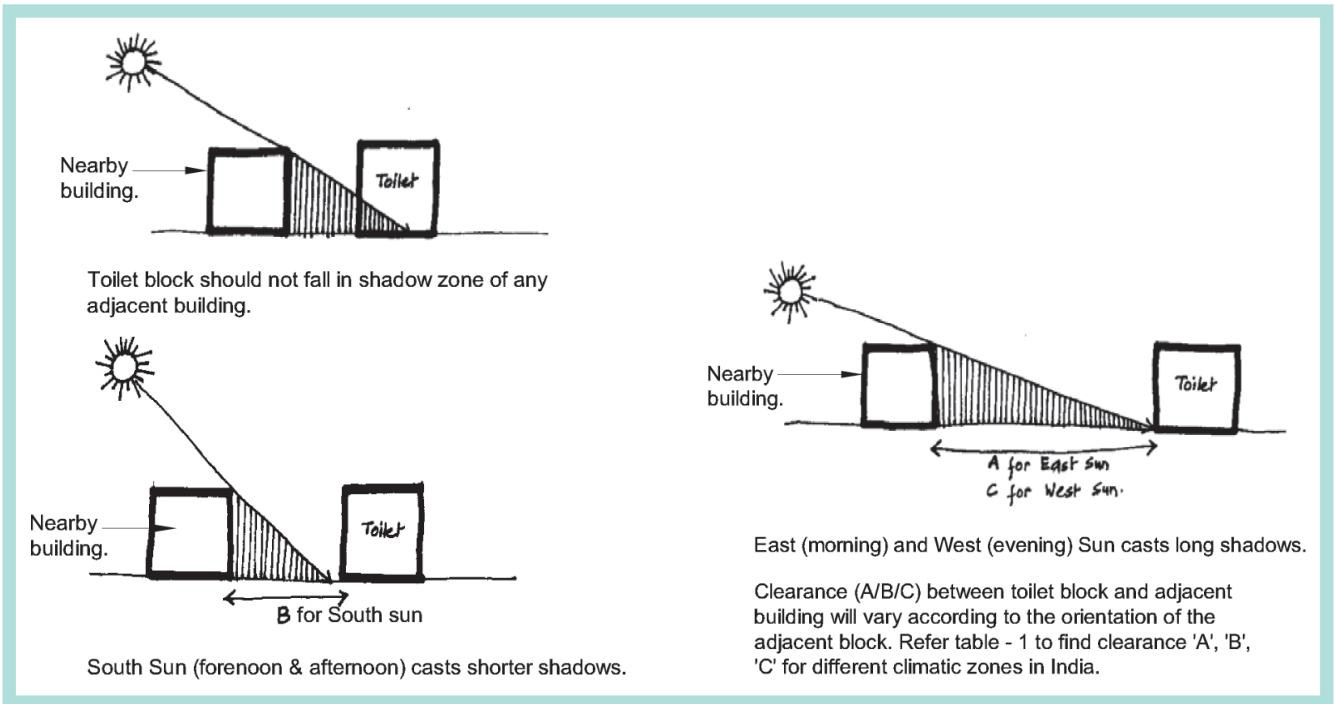

Drawing 2:33. Placement of Toilet Block for Sunlight Penetration

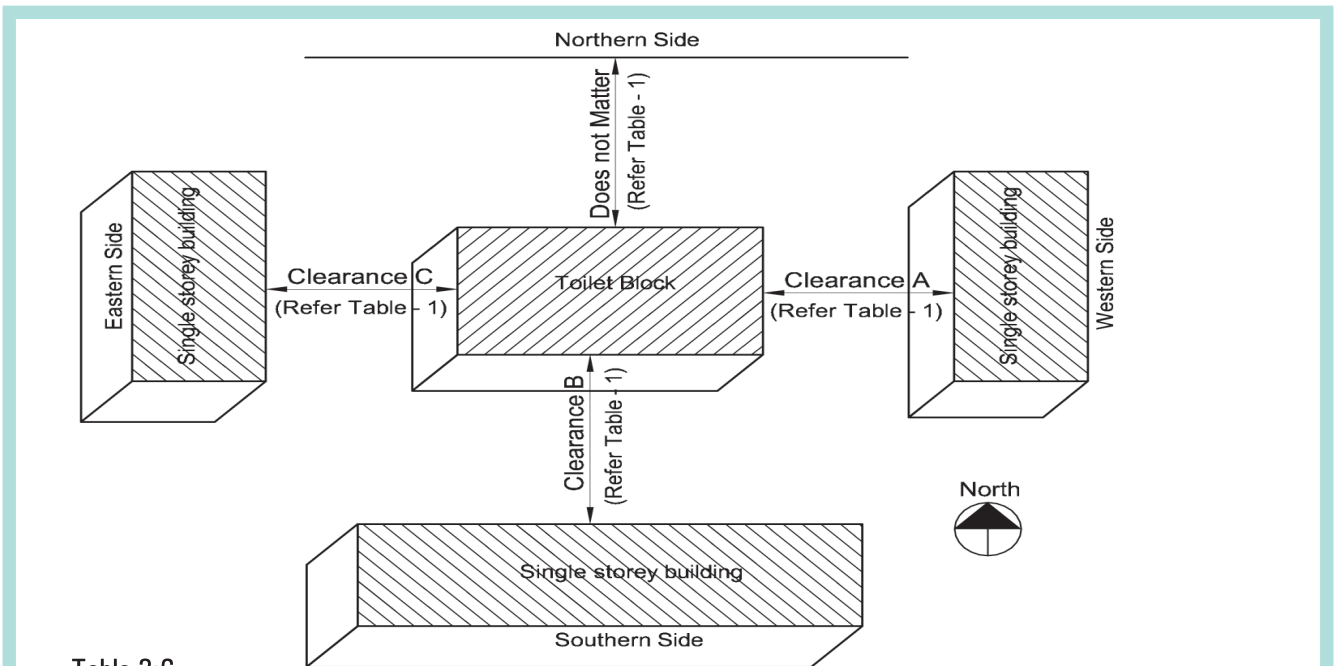

Table 2:6.

Zone		Coastal	Peninsular	East, Central, West	Gangetic Plains	Northern Hilly Zone
Latitude		12° North	20° North	24° North	28° North	36° North
Time	Clearances					
7:30 AM	Clearance A	8.7m	11.76m	14.23m	17.91m	
10:30 AM	Clearance A	2.1m	2.6m	3.03m	3.28m	5.23m
12'o clock	Clearance B	1.56m	2.23m	2.49m	3.3m	4.57m
3:00 PM	Clearance C	3.69m	4.56m	5.23m	5.77m	9.28m
4:30 PM	Clearance C	8.7m	11.76m	14.23m	17.91m	

1. These clearance dimensions are suggested for natural solar passive heating / drying of wet areas i.e. toilets / urinals through ventilators / openings during day time (School hours).
2. With these clearances, sunlight will penetrate the toilets between 7:30am to 4:30pm / 10:30am to 3:00pm as the case may be. If these clearances are reduced, the duration of penetration of sunlight will be reduced accordingly.
3. It is assumed that the toilet is surrounded by single storey building(s) on respective sides.
4. The clearances are from toilet block buildings and not from ramp / landing areas.

4. Determining the safe distance of ground water source from leaching/soak pit of toilet waste disposal

The microbiological contamination of drinking water results in diarrhoeal diseases. Infants and children under five years of age are very susceptible to diarrhoeal diseases and in India they are the second most important health concern contributing to the high incidence of mortality and morbidity among infants and children. Households with latrines close to drinking water sources have higher likelihood of incidence of diseases like hepatitis (jaundice), gastroenteritis,

typhoid and other water-borne diseases like helminthic infestations (worms). This is due to the pathogenic bacteria, virus and protozoa present in defecated material that percolates from the soil and seeps into aquifers in close proximity.

According to a rapid assessment of drinking water quality by WEDC (Water, Engineering and Development Centre) in 2003, it was advised that latrines should be installed 10 meters away from a drinking water source to minimise the risk of pathogens. Another important aspect is that latrines should not be installed uphill of the drinking water source.

Section 5

Other Important Interventions for maintaining Clean Environment in schools

School Sanitation is not limited to School toilets and hand washing facilities; there are a number of other interventions required to keep the environment neat and clean, free from water logging and other solid waste, greenery in the campus and wisely planned water systems.

Experiences so far in SSHE implementation and the project findings of SWASTHH (School Water and Sanitation towards Health and Hygiene) which has successfully been implemented in the states of Jharkhand and Karnataka have shown a positive relationship between school water-sanitation-security infrastructure and pupil access and learning. Results have indicated that children enroll in greater numbers, attend more regularly, remain in school for more years, and learn more effectively when their schools offer clean surroundings, water, toilets and a secure environment. Girls are adversely affected when there are no separate toilets in the schools as it affords them no privacy and also makes them physically vulnerable. Where sanitation facilities exist, members of communities view the schools more positively and parents are also more willing to send children to school. Moreover a clean surrounding has a positive impact on the capabilities of teachers also.

This section outlines some interventions that will enable schools to keep their environment hygienic and thus facilitate proper learning atmosphere.

1. Solid & Liquid waste management for schools
2. Rain water harvesting system in a school
3. Incinerator for girl's toilets in schools
4. Force lift system to pump water from hand pumps

Solid and Liquid Waste Management for Schools

The success of the SSHE programme to a large extent depends on the approach and strategies designed for sustaining the interest of teachers and students in the programme in the post-construction phase. The concept of solid and liquid waste management, in this context, offers an opportunity for adding value to the SSHE

as well as sustaining its programme inputs in a more effective way. Even in rural areas, approximately 15,000 to 18,000 million litres of liquid waste (grey water) and 3 to 4 lakh metric tons of solid waste (organic/recyclable) are being generated each day that are either dumped in landfill sites or remain unattended without proper disposal. This uncollected waste usually finds its way into sewers, is eaten by animals or is left to rot in the open or burnt on roadsides. This waste, if managed and recycled properly, can make the environment cleaner and generate income as well. The schools also generate sizeable amount of waste every day and can provide an excellent platform not only for creating awareness about waste management but to initiate action by involving students and teachers on an institutional basis.

At the level of school, the concept of solid and liquid waste management should be introduced to understand about the collection and disposal system of waste, the technology of solid and liquid waste management, how to operate and maintain the system; and eventually making the school a 'Zero Waste' premise. Waste which can be decomposed by biological processes is known as "biodegradable waste" (e.g. kitchen waste, animal dung, farm waste etc). Organic waste is biodegradable and recyclable. Biodegradable waste gets decomposed in any one of the two ways viz. (a) aerobic (with oxygen), and (b) anaerobic (without oxygen). Waste which cannot be decomposed by a biological process is known as "non-biodegradable waste". Most inorganic waste is non-biodegradable. Non-biodegradable waste which can be recycled (e.g. plastic, paper, old cloth etc.) is known as "recyclable waste" and those which cannot be recycled are known as "non-recyclable waste" (e.g. tetra packs, carbon paper, thermo coal etc.). The principal classification is based on types of solid waste. As far as liquid waste is concerned, it has mainly two forms i.e. black water, a type of waste water generated in the toilet that contains harmful pathogens, and grey water which is waste water generated in the kitchen, bathroom and laundry that may also contain pathogens.

Approaches for waste management at school

School authorities need to take steps for effective management of solid and liquid waste for hygienic environment and surroundings in the school. There are different ways of treating solid and liquid waste.

Solid Waste

- a. Sorting or segregation of waste at source level by keeping biodegradable and non-biodegradable waste in separate colour bins of 5-10 litres capacity each (e.g. green-coloured bin for biodegradable waste and blue bin for non-biodegradable waste).
- b. Treatment/management of biodegradable waste by adopting any one of the following technologies and reuse of treated products:
 - Composting
 - Vermi-composting
- c. Treatment/management of non-biodegradable waste: Some of the sorted out non-biodegradable waste will be of recyclable type. Schools may be encouraged to keep such waste separately and sell it to rag pickers and kabadiwalas and keep the non-recyclable products separately for transportation for community-level waste management.

Liquid Waste

The grey water, in particular, can be recycled by using the technologies of piped root zone system, leach pit and soakage pit. Maintaining a herbal garden by using waste water is a good option if space is available.

Technologies for solid waste management in schools

- **Composting:** Composting is carried out in a simple manure pit or garbage pit (lined or unlined). In this process, aerobic micro-organisms oxidize organic compounds to carbon dioxide and oxides of nitrogen and carbon from organic compounds is used as a source of energy while nitrogen is recycled. As discussed above, in the composting process, due to exothermic reactions, temperature of mass rises. In areas/regions with higher rainfall, composting in over-ground heaps is advisable. The factors affecting the composting process are: (a) Micro-organisms; (b) Moisture, (c) Temperature and (d) Carbon/Nitrogen (C/N) ratio.

For school-level composting, a suitable site should be selected as compost yard for the school taking into consideration wind flow direction so that the inhabited areas do not get any foul odour. The site

should be easily accessible for transportation of waste and manure. It should not be a low-lying area to avoid water logging. Once the site is chosen, the construction of a composting pit or heap should be initiated. The depth of the pit should not be more than 1 meter and its width should not exceed 1.5 meters. The length of the pit may go up to 3 meters. In the pit, waste takes about 4-6 months to compost. Hence, adequate number of pits will be required. Distance between two pits should be more than 1.5 meter. While digging pits, adequate care should be taken to ensure that there is adequate facility to transport the garbage and store the manure.

- **Vermi-composting:** This involves the stabilization of organic solid waste by earthworms which convert the material into worm castings. Vermi-composting is the result of combined activity of micro-organisms and earthworms. Therefore, its technology is a tripartite system which involves biomass, microbes and earthworms and is influenced by the abiotic factors such as temperature, moisture, aeration etc. Microbial ecology changes according to change of abiotic factors in the biomass but decomposition never ceases. Conditions unfavourable to aerobic decomposition result in mortality of earthworms and subsequently no vermi-composting occurs. **Hence, pre-processing of the waste as well as providing favourable environmental condition is necessary for vermi-composting.** Vermitank, used for vermi-composting, is a specialized unit constructed in brick masonry, capable of converting biodegradable solid waste into high quality organic manure in a short period. Operation and maintenance of vermitanks is a simple process.

Technologies for Liquid Waste Management in Schools:

The analysis of the sources of waste water and its types has revealed that more than 90 percent of waste water generated is grey water. Therefore, grey water management is a major challenge in rural areas. In the schools also, enough grey water is generated which if managed properly can be used for kitchen / herbal garden or be diverted to a soakage pit or channel to avoid water logging.

There are a number of simple technologies which may be used at school level for this purpose. The details of some of them are given below.

1. Kitchen / Herbal Garden with piped root zone system
2. Kitchen / Herbal Garden without piped root zone system
3. Leach pit
4. Soakage pit
5. Soakaway Channel

Kitchen / Herbal garden with piped root zone system

With this methodology, treated grey water can be utilized to grow vegetables, flowers or fruits in the premises of the school. This is a simple drip irrigation kind of technology where the grey water will be routed through a pipe with perforations to enable watering of plants. The system has following components:

1. Digging of trench (150 mm to 200 mm depth and 200 mm width)
2. Filling of trench with gravel of size (20 to 25 mm size)
3. A grease trap to collect silt (450mm x 350 mm x 300 mm)
4. Laying of perforated pipe.
5. Perforated non pressure PVC pipe (50 mm diameter and length as per requirement)
6. Covering the trench with polythene sheet.
7. Putting the soil layer (50 mm thickness over the polythene sheet)
8. Construct a leach pit (900 mm diameter with honey comb masonry and water tight cover).
9. Put a layer of earth over (25 mm thickness) over the pit cover.
10. Plant suitable vegetable or flowers at both the side of the trench.

Operation and maintenance (O&M)

1. Periodical cleaning of the grease trap (every week)
2. Cleaning of perforated pipes (once in a year)

Materials required

1. Bricks (150 bricks)
2. Fine Sand (15 gamlas)
3. Cement (1/3 bag)
4. 50 mm non-pressure PVC pipe and length as per requirement
5. Pit cover (1000 mm diameter and 50mm thickness 3 to 4 kg. in height)
6. Polythene sheet

Advantages

1. Simple and cost effective technology
2. Cent percent utilization of water to produce vegetables and fruits
3. Prevention of stagnation of water and
4. Prevention of vector breeding.

Kitchen / Herbal garden without piped root zone system

This is simply canalizing of grey water without any piped system. It is simply routing the grey water through channels by maintaining proper slope to facilitate even watering. The system has following component:

1. A grease trap to collect silt (450mm x 350 mm x 300 mm)
2. A simple bed of appropriate size to absorb the available water;
3. Let the grey water flow into the bed;
4. Plant suitable vegetable or flowers at both the side of the trench.

Operation and maintenance (O&M)

Periodical cleaning of the grease trap (every week)

Materials Required

1. Bricks (50 bricks)
2. Fine Sand (5 gamlas)
3. Cement (1/2 gamlas)

Leach Pit

Leach Pit is a brick lined pit constructed in honeycomb masonry, the size of which can be made as per requirement. They are very useful where waste water discharge is relatively more, these prevent stagnation.

Description

1. Selection of site - the leach pit can be located at any convenient space near the house, keeping a safe distance between the wall and the pit as 1 m.
2. Digging of the pit
3. Construct the pit in circular fashion with honey combing in alternate layers. The pit can be constructed with single brick with a mortar in the ratio of 1: 6.
4. Connect the drain pipe coming from the house to the leach pit via a grease trap.
5. A silt chamber is necessary between the pit and the outlet from the waste water source to avoid entrance of mosquito vectors into the leach pit.
6. The pit should be covered with RCC cover or flag stone slab. The diameter of the cover should be 100 mm more than that of the pit.

Operation and maintenance (O&M)

1. Periodical cleaning of the silt chamber
2. Periodical removal of the sludge from the pit.

Advantages

1. It can handle large volume of water during peak period of water generation and is better suited than soak pits
2. Prevention of stagnation of grey water
3. Prevention of vector breeding

Limitations

Not suitable for rocky terrain.

Soak Pit

Soak pit is a dug out pit filled with stones or preferably over burnt bricks. The large numbers of stones or bricks increase the surface area over which biological and chemical action takes place. The water seeps into the ground and reduces danger of polluting the ground water sources.

Description

An example of making a small soak pit is given below. This can be modified as per the requirements of the school.

Step No.1: Excavation of 1m x1m x 1m pit;

Step No.2: Filling of 1mx1mx1m pit by boulders from bottom 250 mm by 125 mm to 150 mm boulders; 2nd 250 mm layer by 100 mm to 125 mm size boulders; 3rd 250 mm layer by 50 to 75 mm size boulders;

Step 3: Place the 225 mm earthen pot (or plastic container) over the last layer of the boulders;

Step 4: a). Lay twigs (25 mm thick) over the top 250 mm boulders of size 50 to 75 mm size. b). Take a gunny bag, tear it out to make it a bigger piece and lay over the twig (25 mm thick)(Remember to make a hole in the gunny bag appropriately to place the earthen pot.) c). Give one more layer of twig (25mm thick) over the torn portion of the gunny bag;

Step 5: Put a layer of mud over the top twig layer;

Step 6: Put some dry soil over the layer of mud; 225 mm to 250 mm;

Step 7: Make chamber of size 200 mm x 200 mm around the 225 mm earthen pot and plaster at the inner part of the chamber, 20 mm thickness (1:4) and finish it with cement;

Step 8: Connect the bathroom (water) chamber with a 50 mm size diameter non- pressure PVC pipe;

Step 9: Cover the chamber with suitable lid (e.g. wooden plank or a tile).

Advantages

1. This is the cheapest technology for management of water at household level
2. Prevention of stagnation of grey water
3. Prevention of vector breeding

Soakaway Channel

Soak pits can be built in every house for wastewater disposal. But such small pits cannot be of much use near public wells where a large quantity of wastewater flows. In such places pits have to be built like big channels, which are called soakaway channels. Soakaway channel is built where more than 50-60 buckets of water is used. Sludge tanks have to be made to clean and filter the water before entering

such channels. In soak pits a pot with holes is used for filtration of water. As large quantity of water flows into soakaway channels, a sludge tank is provided instead of a pot. Such an arrangement is called soakaway channel with sludge tank.

Advantage

1. Large quantities of community grey water can be absorbed without any open stagnation of grey water;
2. Vector breeding will be prevented;
3. Main water source will not be contaminated;

Description

The system has two major components: Sludge Tank and Soakaway Channel

Sludge Tank

Function of a sullage tank is the same as that of the filter pot in household level soak pit on a big scale. The sullage tank intercepts ash, mud and oily substances in the water and allows the cleaned water to flow to the soakaway channel. Soakaway channel is built near the well and the water allowed to flow into it through the sullage tank.

A sludge tank is generally constructed at a distance of 1.2 to 1.5m away from the well and waste water is taken to it by a drain. First a 93 x 53 x 45cm (deep) pit is excavated. A 15cm thick layer of cement concrete 1:4:8 is laid on the bottom of the pit. A 11.5cm thick and 30cm high brick wall is constructed on the foundation at four sides of the pit. The height of the wall at the point where the drain meets the sullage tank is kept 22.5cm so that a notch is formed, from where wastewater enters the sullage tank. The height of this wall should be 15cm towards the inlet of water and 12.5cm towards the outlet. This wall will divide the tank into two portions each measuring by 30cm x 29.25cm. The first chamber is called grit chamber and second is called grease chamber.

In the tank, other than the one in which water falls, leave a space of 6.25 to 7.5 from the bottom and make a groove of 2.5cm wide in both the walls at center up to the top. Fit in a 25mm thick stone slab in this groove. Fix a pipe 7.5 to 10cm above the bottom in the last chamber for the outlet of water into the soakaway channel. Before using the sludge tank a 10 to 12.5cm thick layer of grass and leaves should be placed in the grease chamber.

Water from the drain first enters the grit chamber of the sludge tank where ashes, mud and other grit materials settle in this chamber and the water flows over the wall in the middle and goes to the other tank. Floating substances like charcoal, oil etc. are intercepted by grass and leaves at this place. Because of the stone slab, the

Drawing 2:34. Sketch of Sullage Tank

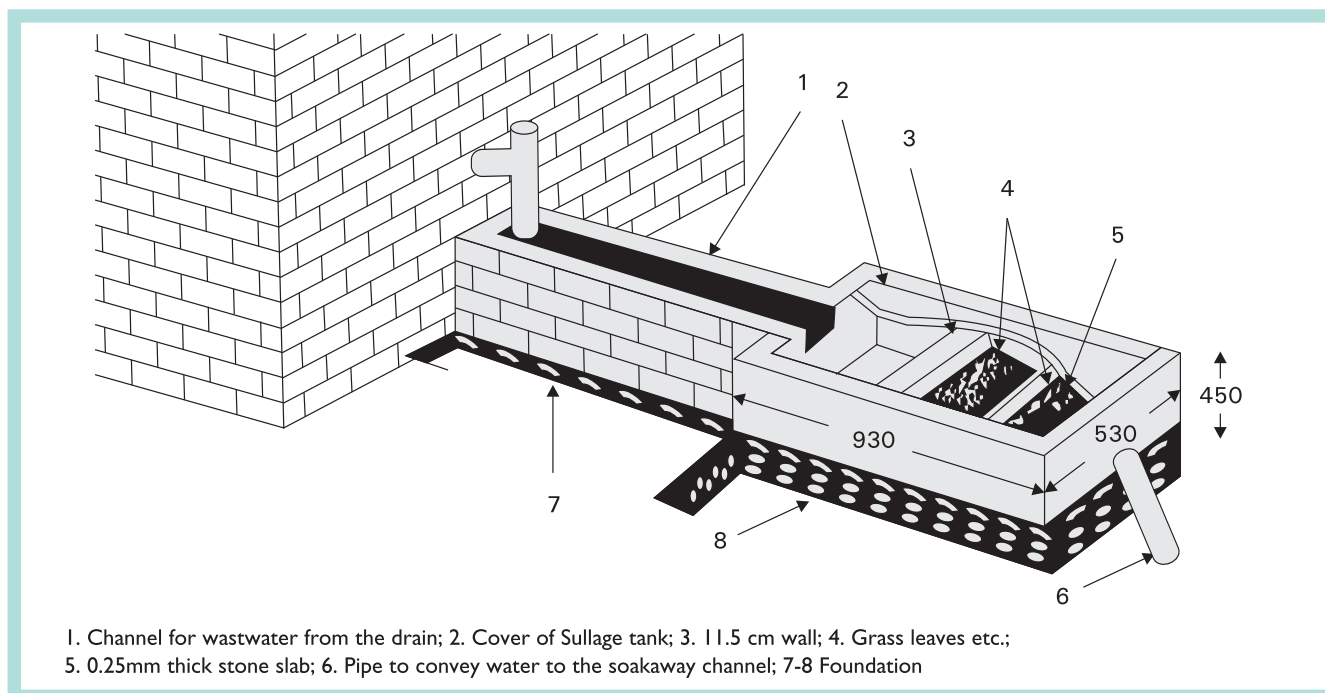

water flows through the grass and leaves etc. and goes into the soakaway channel through the pipe provided at the end of this chamber. This water is well cleaned.

The mud, ash and gritty material collected in grit chamber should be taken out by a spade. Grass and leaves, etc. should also occasionally be removed and fresh ones placed. Some times lime and hypochlorite should be sprinkled in the grit tanks so that insects do not breed. Do not use phenyl, dettol or D.D.T. A container with holes in the bottom can also be used in the grit chamber so that if necessary it can be taken out, cleaned and replaced in the tank.

If large quantity of wastewater is coming, then an extra grease chamber should be built with a slab in it as described above for further cleaning of wastewater. The grit chamber can be built big or small according to the quantity of water used.

If drainage channel is long, smaller tanks may be constructed or colored containers be kept in the passage to intercept the sullage, mud etc. If the soakaway channel is far from the sullage tank then also a tank should be built in between.

Soakaway Channel

Dig a channel 4.5m long and 0.6m broad. It should be 0.6m deep in the beginning and 0.75m in the end. It should be divided into three portions of 1.5m each. The first portion should be filled with round pebbles of 7.5

to 10cm diameter leaving a space of 12.5cm at the top. In the second portion round pebbles of 10cm to 12.5 cm diameter and in the last those of 12.5cm to 15cm diameter should be placed. After this a 7.5cm thick layer of pebbles of 7.5cm to 10cm diameter should be laid on the top throughout. The outlet pipe from the sullage tank should be fixed into the first portion of the channel.

The soakaway channel is covered from above in the same ways as the soak away pit. A 2.5cm layer of non-decaying vegetable matter should be laid over the stones in the channel. Gunny cloth or plastic sheet should be used to cover it so that mud and refuse etc. may not get in. Again a similar layer of non decaying vegetation should be laid and coated with 2.5cm thick layer of mud. Then put dry earth over it, so that its level may be 15cm above ground level. Gradually this earth will get pressed and be level with the ground. Carts and trucks can pass over the soakaway channel without causing any damage to it.

Rain water harvesting system in a school

It is very important today to conserve water especially in a rain dependent country like India. The rain water during monsoons if collected and system is developed to store it, this water can be used during the lean / dry months. The technology by which rain water is collected, stored and then re-used after treatment is called rain water harvesting. This is being successfully implemented in different parts of the country at the household as well as community levels.

Drawing 2:35. Channelising roof top run off rainwater

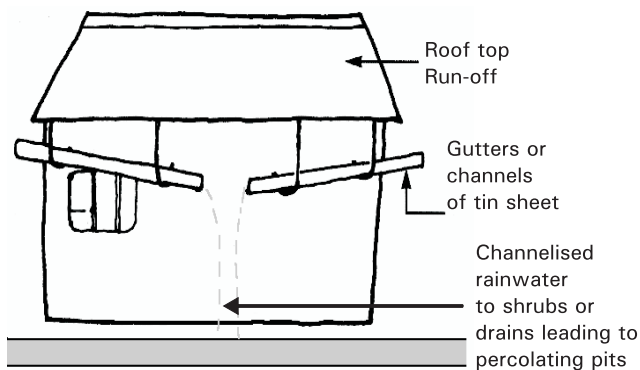

Rainwater falling on the roof can be directed to fall at a few chosen spots, through open pipes of simple tin sheets placed at the edges of the roof. These chosen spots can be near the vines planted adjacent to the buildings (for example, along pillars/poles). Rooftop water can also be directed to rows of shrubs, small trees or trees in the vicinity of buildings. This is very exciting, for a large part of the water requirements of planted trees can be met in this way. Other than what the trees draw, the rest of the water gradually percolates into the ground. If the roof sheets are coated on the top exterior surface with good quality turpentine-based enamel paint (of light reflective colour like white or yellow), simple water harvesting structures will enable water to percolate and replenish ground water.

With innovative (and not very elaborate) landscaping, it is possible that all the rainwater that falls in the school area (and not just roof water), percolates into the earth and does not run-off to drains. This water would make living greens like the ones that are planted and many self-occurring one's spring forth. This is very exciting for a school and it also drastically reduces the need for watering plants. It is like setting up (or rather helping nature evolve) a self-sufficient natural system. The rest of the rainwater will recharge the plummeting groundwater table. Interaction and adjustments of the landscape (contours and gradient) of the open spaces in the school area is required to help rainwater travel towards the existing and planned green spaces. Small trenching etc. in these spaces and improvement of soil conditions towards increasing percolation potential will ensure that the rainwater falling in the school area zone is utilised to the maximum. Another design (especially when all water cannot percolate in a spread out way as above, usually due to lack of soft soil space) is to make strategically placed rainwater harvesting or recharge structures. Other than the direct benefits, children will get a first hand experience of how water can be harvested and utilised.

Incinerator for girl's toilets in schools

Both biodegradable and non-biodegradable waste can prove hazardous for health, if proper and complete disposal is not done. In schools especially, disposal of sanitary cloth and sanitary napkins in girl's toilets is a big problem. The napkins affect the proper functioning of toilets when disposed in the toilet and serious health problems if thrown out in garbage dumps or in the open. There is, thus an imminent need to address this sanitary waste disposal effectively, especially in terms of developing cost-effective and simple technology for composite waste disposal for schools.

An innovative low-cost technology incinerator has been developed for proper disposal of sanitary waste. This design is simple, safe and cost effective. It has already been installed in many rural schools and women's sanitary complexes.

The incinerator comprises of two chambers, an emission control system along with a door for firing and removal of ash. In each incinerator, there is a spout/opening in the toilet wall for disposal of soiled napkins into the chamber. The soiled napkin drops on the wire gauze in the chamber on the other side of the toilet wall. This dropped napkin and other waste are fired on weekly basis through the door/firing inlet in the lower chamber. The entire incinerator is attached to the outer wall of the toilet. A smoke vent is provided for the disposal of gaseous substances while firing the sanitary wastes.

This simple addition to the toilets is highly appreciated by girls and teachers. The use of the incinerator has removed inhibitions among girls on attending schools during menstruation and has made them comfortable attending school during those days. There are also no

Drawing 2:36. Masonry incinerator outside girl's toilet

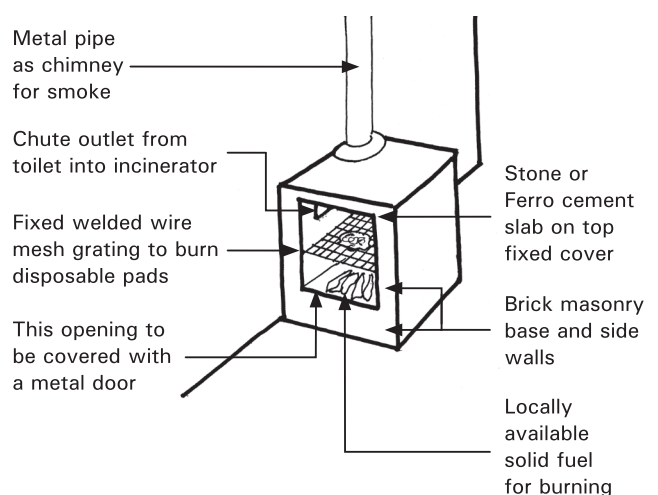

Drawing 2:37. Chute for Incinerator from Girl's Toilet

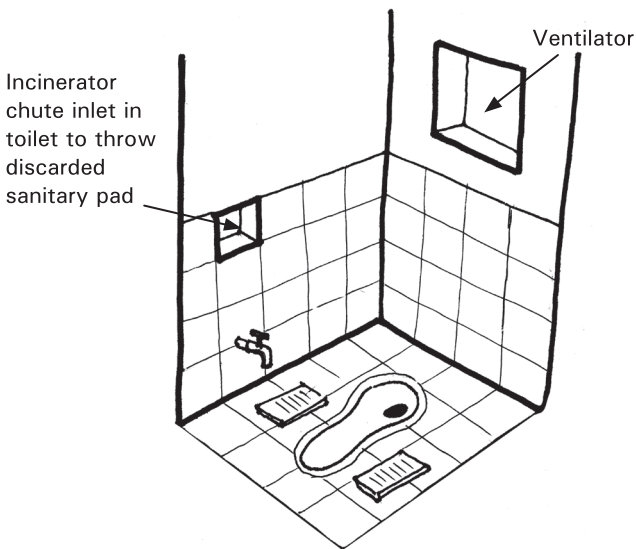

blockages of toilets due to sanitary waste disposal in the toilets.

In another suggested design, an existing drum can be modified to be used as an incinerator. For this, a simple drum used in households will be lined with a perforated fire bed as shown where used napkins will get collected coming through the chute made on top, like in letter boxes. At the bottom of the drum, there will be an opening / space to enable firing of these napkins. There will be a smoke vent / chimney for disposal of gases while firing.

Force Lift system to pump water to tanks from hand pumps

Experience over the years has shown that one key intervention critical for proper use and maintenance of the provided facilities and promotion of hygiene behaviors is availability of running water. Manual filling of water to tanks for cleaning up toilets and washing hands do work initially but gradually the enthusiasm for this routine task fizzles out. Having piped/running water availability at all times has been an expensive alternative and funds have been a constraint for this component.

The Force Lift Hand Pump (FLHP) technology is very simple and effective in providing running water through overhead tanks where there is no electricity or regular power supply is not assured. A functional hand pump (India Mark II/III) can easily be converted to FLHP through force lift and motorized conversion kits/attachments which are available for the deep well

Drawing 2:38. Metal Barrel /Drum to be modified as Incinerator

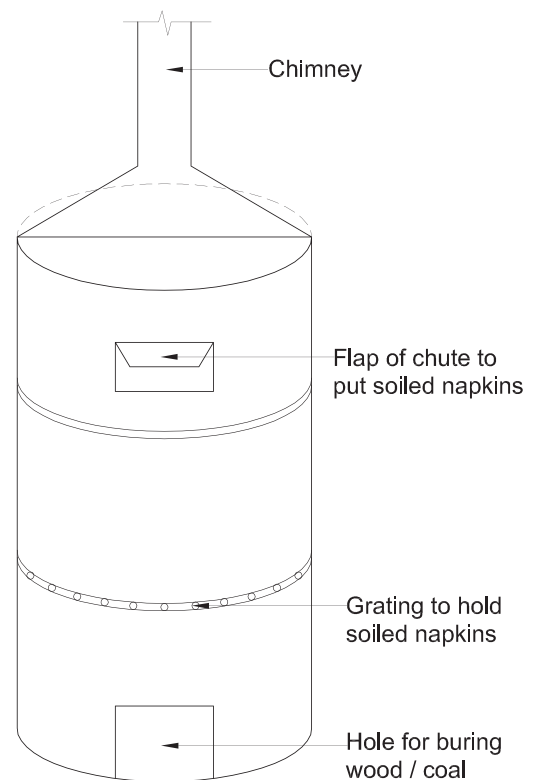

pumps. The force lift pumping system/arrangement is designed to deliver water up to a height of 15 meters from ground level. Introduction of a tap near the spout allows the spill-over water to be stored in an overhead tank while the hand pump is being used for drinking water or any other purpose, without any extra effort. The cost of installing the force lift pump is approximately Rs 3,000 though there may be wide variation as per the site conditions. The main features of FLHP are:

- Capacity to lift water to an overhead tank (4 to 15 meters above ground level);
- No change in head assembly and below the ground structure;
- Introduction of non-return valve, flange gaskets and overhead tank;
- Replacement of third plate assembly on Mark II/III hand pump;
- Gravity flow;
- Optimal utilization of waste water from hand pumps;
- Easy use at the household, school or community level.

Provision of running water inside the toilets and toilet blocks has been able to promote hygiene practices such as keeping the toilets clean and hand washing more effectively and thus the FLHP is an important intervention.

Drawing 2:39. Modifications to IM II handpumps for Force & Lift applications

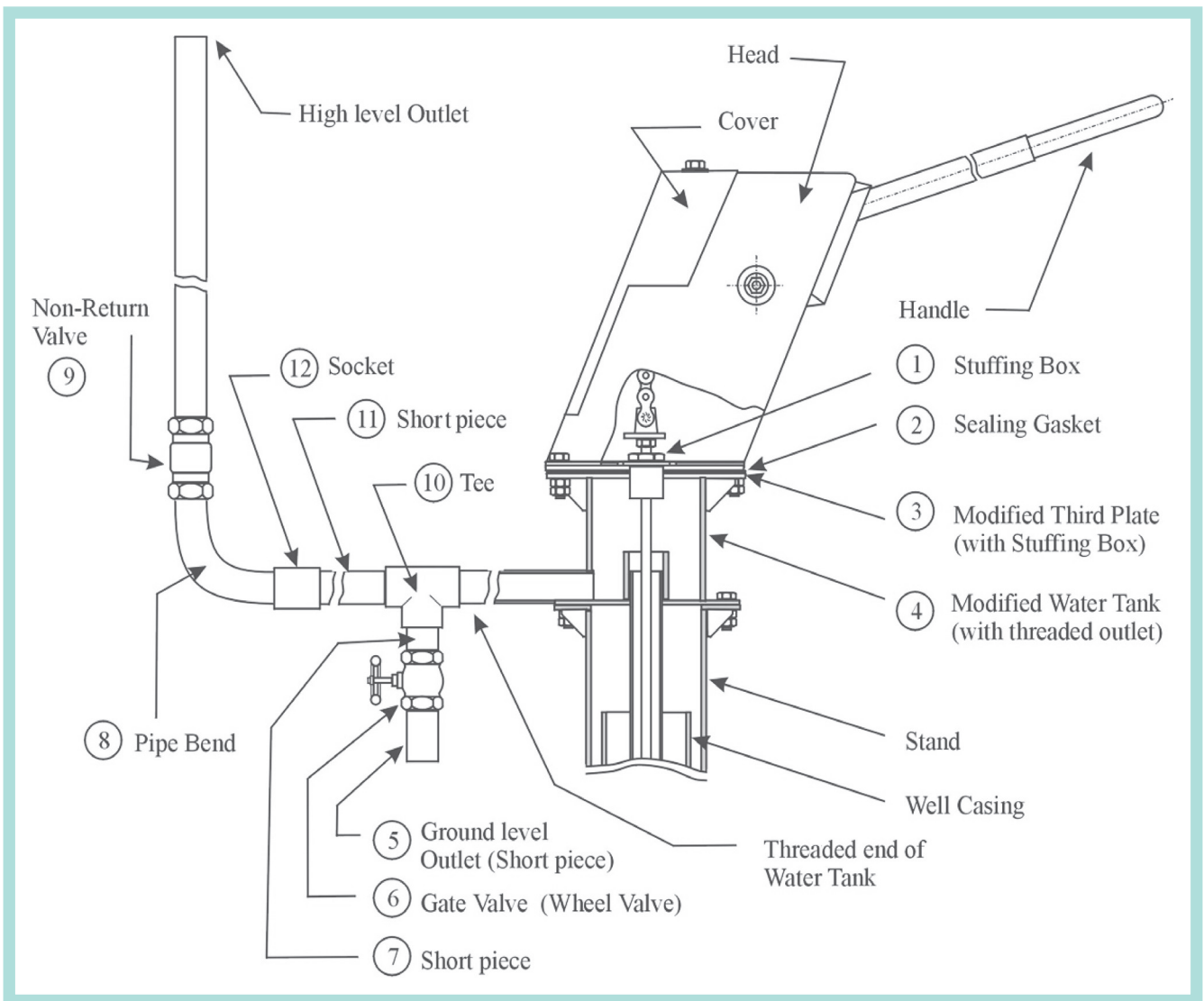

Drawing 2:40. Conversion Kit Components for IM II Force & Lift Handpump

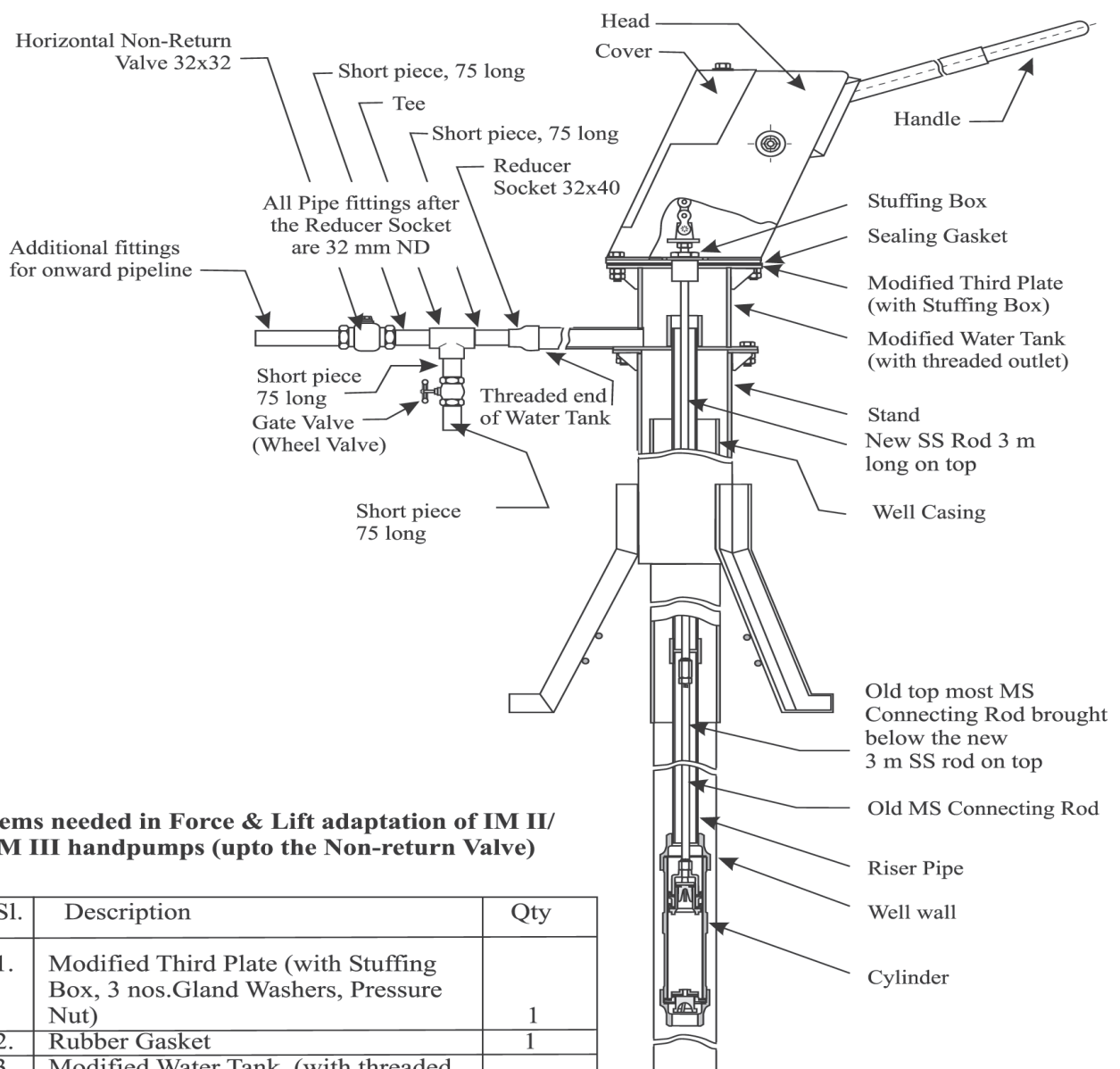

Items needed in Force & Lift adaptation of IM II/ IM III handpumps (upto the Non-return Valve)

Sl.	Description	Qty
1.	Modified Third Plate (with Stuffing Box, 3 nos. Gland Washers, Pressure Nut)	1
2.	Rubber Gasket	1
3.	Modified Water Tank (with threaded outlet, 40 mm NB pipe)	1
4.	Gate Valve 32 mm	2
5.	Pipe nipples (Short pieces), 32 ND, 75 long, medium class	4
6.	Reducer Socket 32 x 40 ND, heavy duty	1
7.	Tee 32 x 32 x 32, heavy duty	1
8.	Non Return Valve (horizontal)	1
9.	M12 GI Bolts, 50 long, with Nuts	4
10.	Connecting Rod, SS, 12 mm Dia, 3 m long, threaded both ends, with SS M12 lock nuts for both ends and one long coupling	1

All dimension in mm
Tolerances: +0.5 mm unless otherwise specified
Drawing not to scale



PART III

Preparatory Planning, Designs and Estimates

Introduction

This part discusses the preparation necessary before planning sanitation facilities in schools, and presents a range of design options with corresponding cost estimates based on the norms and criteria discussed in the previous sections.

There are five sections in this part:

1. Preparatory planning.
2. Understanding the designs, their attributes and features.
3. Design selection tool to decide which design is suitable for a scenario / situation.
4. A set of 16 designs with their salient features, technical drawings and bill of quantities.
5. A set of designs from five states - Andhra Pradesh, Gujarat, Jharkhand, Madhya Pradesh and Orissa - which have been used as the base for developing the new designs.

Background to design development: the review of designs developed by states

It must be acknowledged here that these designs have been developed after a very detailed review of the design developed in past few years by various states. These were Andhra Pradesh, Assam, Bihar, Chhattisgarh, Gujarat, Jharkhand, Karnataka, Maharashtra, Madhya Pradesh, Orissa, Rajasthan, Tamilnadu, Uttar Pradesh, and West Bengal. As part of development of this document, this review provided a lot of insight on design renewal. The designs presented in this section are an outcome of this review and renewal exercise.

Indicated rates for construction of designs in this document

The indicated rates given with each design are based on Bihar Schedule of Rates (SoR) 2005 with an index of 18% for 2008. However, each state may use its own specific SoR to arrive at its own rate for the purpose of estimation and costing. A comprehensive sheet to help the users of this document to use this data is given in the annexure.

Section 1

Preparatory planning for sanitation facilities in school

This section details out the preparatory steps for school sanitation activities which will be very helpful in the planning process and thereafter implementing the programme. Following are the suggested guiding steps:

Obtaining data and establishing need

- Obtain the data on present school strength of boys, girls and school staff.
- Obtain the data on future school strength (say in next 5 to 10 years) of boys, girls and school staff. Census data and projections may also be used for this.
- Check if there is water source within the school premises.
- Obtain the data on present provision of amenities in the school.
- Analyse, if they are adequate or need augmentation.
- Based on the norms given, determine the present and the future requirement of various amenities.
- Discuss with school administration site-related issues – land available, security and safety, future plans for school expansion and finally their need.

Identify site for facilities

- Survey the site(s) for construction of sanitation block.
- Identify zones where the amenities can be located.
- Prioritise options, based on various parameters.

Selecting the design

- Identify the range of design options and technology options that seem most feasible on this site.
- Check the design most suitable for the site.
- Check the technology most suitable for the site.
- Finally see, if the design fits into the larger 'master plan' (if any) of the school.

Location and placement

Before finalising the location(s), analyze the site for the following:

- Is the site for the toilet the best from the point of view of usage and safety of all users? E.g. is it readily accessible to all children, remains under visual command of school management, etc.

- Does the site offer enough space for good ventilation and natural light? E.g. Is the longer side of the toilet block facing south, west or east? Are the openings located on the windward side?
- Does the site offer enough space for future need/ expansion? E.g. Is there enough space/clearance for the amenities to expand side-ways/front/back in future without adversely affecting the efficiency of present buildings and facilities?
- Does the site offer any blockage in the natural site drainage? E.g. what has been the natural site drainage pattern on the site? If there is any blockage will the new building further increase it?
- Will the drainage of waste and soil water be proper and safe? E.g. there is sufficient space for accommodating the type of sewage disposal system that is most suitable on site? Is this point adequately away from the ground water source used by the school or the community?
- Will the location of amenities affect the performance of existing buildings negatively? If so, can these be minimised? E.g. will construction affect the natural light and ventilation of present classrooms?
- What level of adaptations/modifications will be needed to 'fit' the design on site? Will they still keep the cost within the budget? E.g. some adaptations may actually reduce the cost – an existing boundary wall or a common wall may be used. However, some adaptation may increase the cost – a new wall may need to be introduced.
- Will the location of incinerator be comfortably accessible and safe for burning? E.g. will its location be such that when the incinerator needs to be activated, it is accessible to school authorities and is also safe from fire hazard or child safety?
- Based on these, finalise the location and orientation of the toilet building.

Reviewing the selected site

- Make sure that the site gives the best possible orientation to the building design.

- See if the urinals or toilets get direct sun light at least once in the day and there is sufficient cross ventilation possible.

Site-specific adaptation

- Make site-specific adaptations in the design according to need.
- Check how the drainage from the amenities can be most efficiently recycled or safely discharged.
- Identify the most frequently used path to approach the facilities being created. Check if it is safe as well as conducive for all children including CWSN.
- Analyze, which environmentally good practices can be used with the design on this site.

Creating stake of school community

- Identify what can be role of the various stakeholders of the school community in making and maintaining the facilities created. This must include the children as well.
- See if there are any existing resources (material and human) that can be effectively used to make better facilities or to make the facilities cost-effective. Map them and use them in the best possible way.

- Check if the necessary skills and building materials are available locally. If not, can some specification be modified without affecting the quality or performance? If not, then what is the way out?
- Make an execution plan and discuss with the school community.
- If required, orient them and sensitise them through photographs, drawings and rough sketches of the plan, anecdotes, etc.
- Take inputs from the school community and fine tune the design.

Preparing for implementation

- Make necessary modifications in the estimate.
- Check if some resources can be brought in through convergence.
- Assign role to different stakeholders in the process.
- Identify the construction agency and assign the job.
- Now the design is ready for construction.

Note: In-house engineers, appointed under the SSA in civil works unit in some states, are familiar with the above mentioned processes in the schools. These engineers can effectively deliver the process and products mentioned above.

Section 2

Understanding the designs

Suggested designs

It must be clearly understood that these are suggested designs, keeping in mind the ground realities. But, availability of materials and skills as well as geo-climatic condition varies across the country and even within a state. Hence a region that has stone-based construction or a region that has bamboo-based construction systems will need to adapt these designs. This is perfectly acceptable as long as the adapted design addresses the norms and the design principles given in this document.

Designing for economy and optimisation

It may be noticed that the designs are made for economy and optimisation of resources. As a result, all designs have sloping roof with lightweight tile over a metal/timber under-structure. In case of a flat roof (which will be either of stone or RCC) the load will be higher and it will also need terracing for waterproofing. The combined result of this will be higher overall cost in making thicker walls, deeper and wider foundations and in terracing. It may also affect the natural ventilation in toilets. Due to lighter weight of a sloping roof, it is being suggested even for the regions where the rainfall may not demand such roofs.

Designs for children as well as teachers and adults

All the designs suggested have been designed keeping in mind that they will be used by children as well as teachers in the school. The hardware and plumbing provisions keep this dual use in mind for all the girls and boys toilets and urinals including CWSN toilets.

Design types

Based on the essential and desirable components, proposed norms, guiding principles of design of SSHE facilities, several sample designs have been developed and are being illustrated here. These are broadly classified as follows:

1. **Basic Core Designs** (BCD) for boys and girls and for **Linear** and **Corner** situations.
2. **Expandable Core Designs** (ECD) for **Linear** and **Corner** situations.

1. Basic Core Designs (BCD)

Basic Core Designs (BCD) for Linear and Corner situations address Linear and Corner site situations and are meant for those schools that may not need any expansion. They have separate blocks for girls and boys that may also share a common wall. BCD is sufficient for 80 students (assuming 40 girls and 40 boys) and all teachers.

All Basic Core Designs (BCDs) use the modular approach to design. In other words, each component can be seen as a module that can be interchanged/ adapted to suit a particular site situation. The bare essential features of the Basic Core Design are, common for all designs. These are:

1. Compact core design;
2. Core is designed differently for linear as well as corner site situation;
3. Separate girl's and boy's toilet block;
4. One toilet and two urinals if designed for 40 students and one toilet with four urinals if designed for 80 students;
5. In case the total number of children is below 80 then only the girl's toilet block can be made;
6. Use of natural ventilation and lighting for solar passive drying and hygiene;
7. Toilet maintenance/upkeep storage provision;
8. Special provisions in girl's toilet for hygiene and sanitary napkins:
 - a) Niche to keep napkins;
 - b) Incinerator linked with girl's toilet for hygienic disposal.
9. Integrated wash facility inside each toilet for better hygiene;
10. Common water storage up to 500 litres is integrated with plan;
11. Common wash facility with running water outside both toilet blocks for multiple use;
12. Recycling of waste wash water to wash urinals;
13. Common leach pit and soak pit for both blocks;
14. Entire toilet block area is covered with lightweight, breathable, durable roof.

The Basic Core Designs have following limitations:

1. They cannot be expanded for future needs;
2. They are not designed for Children with Special Needs;

3. The common wall between boy's and girl's toilet area may ignore the behavioural issues.

It may be noted that for each design type various site orientation options have been also given to help locate the best site within school campus.

2. Expandable Core Designs (ECD)

The Expandable Core Designs for Linear and Corner site situations are meant for schools that have the potential for future expansion. Some of these designs also include features for Children with Special Needs (CWSN). In ECD, only the initial core will expand and will be accessible to CWSN. Subsequent expansion(s) will utilize the facilities provided in the core in an expandable manner. It may be noted that for site planning, sufficient clear space for future expansion has to be left at the beginning, as per respective design and site situation. Typically they occupy more area than Basic Core Designs and hence cost more, but take care of several issues for the future that reduce the cost in the long run. In general, they largely address most of the guiding principles of design while taking care of essential and optional components as well as norms.

Other salient features are as follows:

1. Modular in nature for flexibility.
2. Expandable core.
3. Universal and inclusive.
4. Conserves water and its use.
5. Segregates solid and grey/waste water.
6. Designed for low maintenance.
7. Has solar passive design for effective hygiene.
8. Accessible storage.
9. Address user tendencies and behaviour.
10. Address linear typology of site shapes and form.
11. Gives expandability option in the front/ side / rear (as the case may be) for future needs.
12. Common ramp will serve both the boy's and girl's toilet. Common ramp, wash area can service all the modular expansions.
13. Common leach pit can service up to two modular expansions.
14. Adaptable to different geo-climatic conditions.
15. Ventilation of the core area remains unaffected even after expansion.

16. Segregated wash space in the front, so that one need not enter the toilet for merely washing purpose.

The limitations of these designs are:

1. Basic size is larger than BCD and hence the cost is higher.
2. Space for expansion has to be left in advance.

It may be noted that for each design type various site orientation options as well various possibilities of expansion have been given to help locate the best site within the school campus.

The following 16 designs of toilets are suggested that cater for different requirement of schools (these are BCD and ECD types):

- 01 BCD 40B
- 02 BCD 40G
- 03 BCD 80B
- 04 BCD 80G
- 05 BCD CWSN 40B
- 06 BCD CWSN 40G
- 07 BCD CWSN 80B
- 08 BCD CWSN 80G
- 09 BCD Linear 40G+40B
- 10 BCD Corner 40G+40B
- 11 BCD Linear 80G+80B
- 12 BCD Corner 80G+80B
- 13 ECD CWSN 40G+40B Expansion linear
- 14 ECD CWSN 40G+40B Expansion Corner
- 15 ECD 80G+80B Expansion Linear
- 16 ECD 80G+80B Expansion Corner

It may be noted that all designs are developed so that adult teachers (ladies and gents) can also use the facilities, hence there is no need for separate toilets or urinals for them. The present set of designs is not developed for multi-storey structures. Also, these are presently based on offset single or double pit latrine with pour-flush. But this should not restrict the users of this document to explore other technology options like:

1. Direct single pit latrine without pour-flush
2. Direct double pit latrine without pour-flush
3. Solar heated single-vault ecological latrine with urine separation
4. Double- vault ecological latrine with urine separation

Attributes of toilet design options at a glance

Table: III.1

Sl no	Code	Expandability		Gender				Inclusiveness		Strength for one gender		Layout/ space availability	
		Basic and non expandable	Expandable	Boys only	Girls only	Boys and girls	CWSN	Non CWSN	40	80	Linear	Corner	
01	01 BCD 40B	✓		✓				✓		✓		✓	✓
02	02 BCD 40G	✓			✓			✓		✓		✓	✓
03	03 BCD 80B	✓		✓				✓		✓	✓	✓	✓
04	04 BCD 80G	✓			✓			✓		✓	✓	✓	✓
05	05 BCD CWSN 40B	✓		✓				✓		✓		✓	✓
06	06 BCD CWSN 40G	✓			✓			✓		✓		✓	✓
07	07 BCD CWSN 80B	✓		✓				✓		✓	✓	✓	✓
08	08 BCD CWSN 80G	✓			✓			✓		✓	✓	✓	✓
09	09 BCD Linear 40G + 40B	✓								✓		✓	
10	10 BCD Corner 40G + 40B	✓								✓		✓	✓
11	11 BCD Linear 80G + 80B	✓								✓		✓	
12	12 BCD Corner 80G + 80B	✓								✓		✓	✓
13	13 ECD CWSN 40G + 40B Expansion linear		✓					✓			✓		
14	14 ECD CWSN 40G + 40B Expansion Corner		✓					✓			✓		✓
15	15 ECD 80G + 80B Expansion Linear		✓					✓			✓		
16	16 ECD 80G + 80B Expansion Corner		✓					✓			✓		✓

Section 3

Design Selection Tool

Selecting the most suitable design for your site

The design can be selected on the basis of:

1. Strength of children in school.
2. Presence of existing functional toilet/toilets in the school.
3. Nature of space available in school – linear or corner.
4. Requirement for expansion.
5. Inclusive designs.

The table below helps in selecting a design from the mentioned 16 design options based on the requirement/s of a particular school.

Scenarios in a school and selecting the most appropriate design:

It is suggested to go through all the scenarios described below in order to arrive at the most suitable design for the situation.

1. Toilet for girls only needed:

There is already one toilet block in the school, but there is no separate toilet block for girls. Depending on the strength of enrolled girls, either of the following toilet designs can be made:

- 02 BCD 40G (for 40 girls)



- 04 BCD 80G (for 80 girls)



- 06 BCD CWSN (for 40 girls)



- 08 BCD CWSN (for 80 girls)

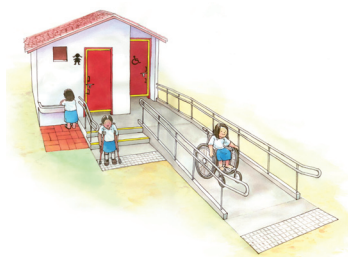

2. Toilet for boys only needed:

There is already one toilet block in the school which can be used by girls but there is no separate toilet block for girls. Hence present toilets can be used by girls and the new toilets can be made for boys. Depending on the strength of enrolled boys, either of the following toilet designs can be made:

- 01 BCD 40B (for 40 boys)



- 03 BCD 80B (for 80 boys)

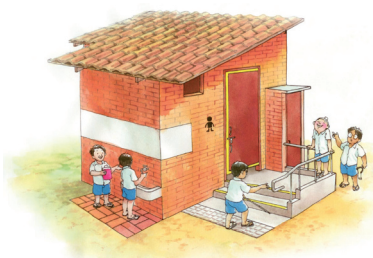

- 05 BCD CWSN 40B (for 40 boys)

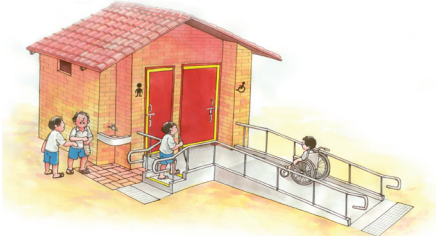

- 07 BCD CWSN 80B (for 80 boys)

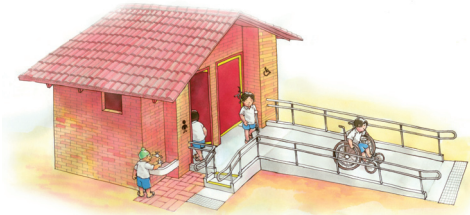

- 05 BCD CWSN 40B (for 40 boys + Children With Special Needs)

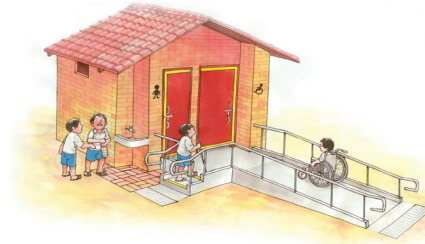

- 07 BCD CWSN 80B (for 80 boys + Children With Special Needs)



3. Toilet for girls only and CWSN needed:

There is already one toilet block in the school, but there is no separate toilet block for girls and for CWSN. Depending on the strength of enrolled girls, either of the following toilet designs can be made:

- 06 BCD CWSN 40G (for 40 girls + Children With Special Needs)



- 08 BCD CWSN 80G (for 80 girls + Children With Special Needs)

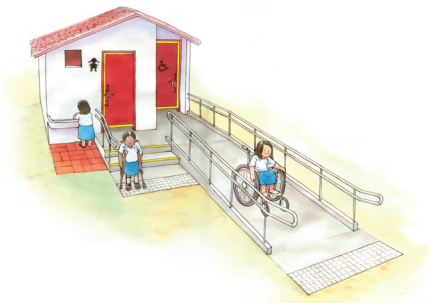

4. Toilet for boys only and CWSN needed:

There is already one toilet block in the school, which can be used by girls but there is no separate toilet block for girls or CWSN. Hence present toilets can be used by girls and the new toilets can be made for boys and CWSN. Depending on the strength of enrolled boys, either of the following toilet designs can be made:

5. Toilets for girls and boys needed on a linear site:

There is need for new toilet blocks due to either of the following reasons:

1. Existing toilets are dilapidated and cannot be repaired for use.
2. The existing toilets are inadequate given the number of children enrolled and attending the school.
3. There are no toilets and new toilets are needed.

The site for locating the new block of toilets is linear in shape. In this scenario, the following designs may be considered based on enrolment of children for whom there is no toilet facility:

- 09 BCD Linear 40G+40B (for 40 girls + 40 boys on Linear site)

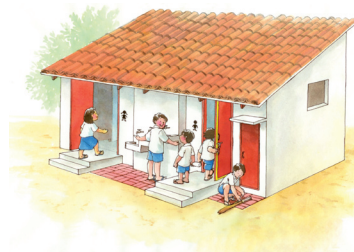

- 11 BCD Linear 80G+80B (for 80 girls + 80 boys on Linear site)



- 13 ECD CWSN 40G+40B Expansion Linear

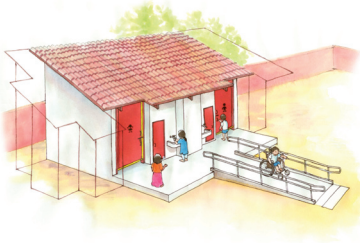

- 14 ECD CWSN 40G+40B Expansion Corner



- 15 ECD 80G+80B Expansion Linear



- 16 ECD 80G+80B Expansion Corner



6. Toilets for girls and boys needed on a corner site:

There is need for new toilet blocks due to any of the following reasons:

1. Existing toilets are dilapidated and cannot be repaired for use.
2. The existing toilets are inadequate given the number of children enrolled and attending the school.
3. There are no toilets and new toilets are needed.

The site for locating the new block of toilets is in a corner. In this scenario, the following designs may be considered based on enrolment of children for whom there is no toilet facility:

- 10 BCD Corner 40G+40B (for 40 girls + 40 boys on corner site)

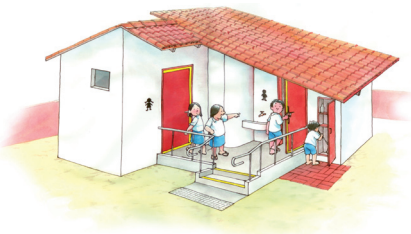

- 12 BCD Corner 80G+80B (for 80 girls + 80 boys on corner site)

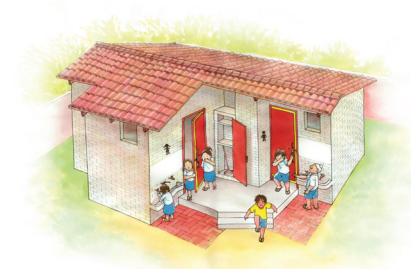

7. Toilets for girls and boys needed with scope for future expansion on a linear site:

There is need for new toilet blocks due to any of the following reasons:

1. Existing toilets are dilapidated and cannot be repaired for use.
2. The existing toilets are inadequate given the number of children enrolled and attending the school.
3. There are no toilets and new toilets are needed.

The site for locating the new block of toilets is linear in shape. The school is growing and in future the school may expand as more children are enrolled. In this scenario, the following design may be considered based on enrolment of children for whom there is no toilet facility presently:

- 15 ECD 80G+80B Expansion Linear. (for 80 girls + 80 boys with option for future expansion on Linear site)



In addition to the above, in case there is need for a toilet for CWSN, consider the following:

- 13 ECD CWSN 40G+40B Expansion linear (for 40 girls + 40 boys + Children With Special Needs with option for future expansion on Linear site)

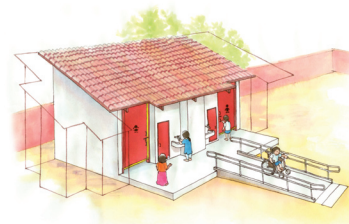

8. Toilets for girls and boys needed with scope for future expansion on a corner site:

There is need for new toilet blocks due to any of the following reasons:

1. Existing toilets are dilapidated and cannot be repaired for use.
2. The existing toilets are inadequate given the number of children enrolled and attending the school.
3. There are no toilets and new toilets are needed.

The site for locating the new block of toilets is in a corner. The school is growing and in future the school may expand with enrolment of more children. In this scenario, the following designs may be considered based on enrolment of children for whom there is no toilet facility presently:

- 16 ECD 80G+80B Expansion Corner (for 80 girls + 80 boys with option for future expansion on corner site)

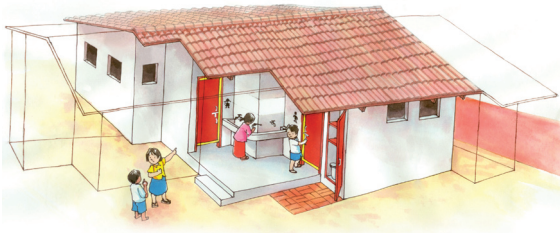

In addition to the above, in case there is need for a toilet for CWSN, consider the following:

- 14 ECD CWSN 40G+40B Expansion Corner (for 40 girls + 40 boys + Children With Special Needs with option for future expansion on corner site)



9. Toilets for girls and boys needed with scope for future expansion with CWSN:

- 13 ECD CWSN 40G+40B Expansion Linear



- 14 ECD CWSN 40G+40B Expansion Corner



After short-listing the designs

The above exercise will help in short-listing a particular design type. For further help, detailed notes with each design have been given for more clarity. Typically, with each design, the information is arranged in six sheets in the following format:

Sheet 1

1. A coloured view of a design: this will give a visual impression of the toilet design.
2. Indicative Cost (based on Bihar SoR 2005 with an index of 18%) and total built-up area.
3. Additional salient features, not part of the basic core design: this will help in taking an informed decision about selecting a design.

Sheet 2

4. Guide to orient a design with the best/second best/ third best possible orientation on the site.

Sheet 3

5. Detailed technical Plan of the design with notes.

Sheet 4

6. Detailed technical Section of the design with brief specifications.

Sheet 5

7. Detailed technical Elevation of the design.

Sheet 6

8. Bill of quantities of items of work.

Section 4

Designs

The following pages have all the 16 design options with its outside view, orientation, plan, elevation and section with details.

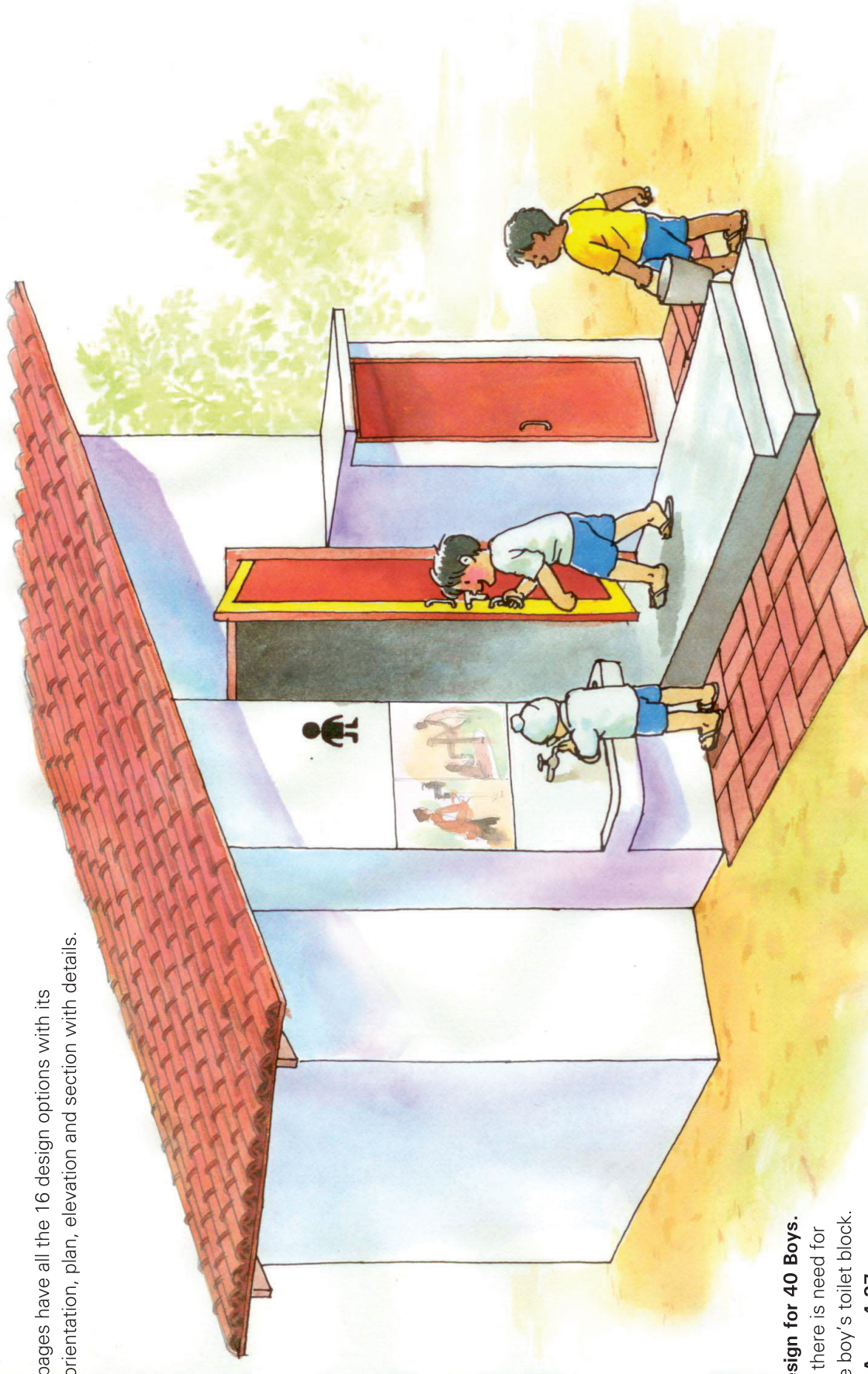

Basic Core Design for 40 Boys.
 Suitable when there is need for
 only a separate boy's toilet block.
Total Built-up Area: 4.37 sq.m
Indicative cost* Rs 35,245

* The costing is based on Bihar Schedule of Rates (SoR) of 2005 with an enhanced cost index of 18% for 2008

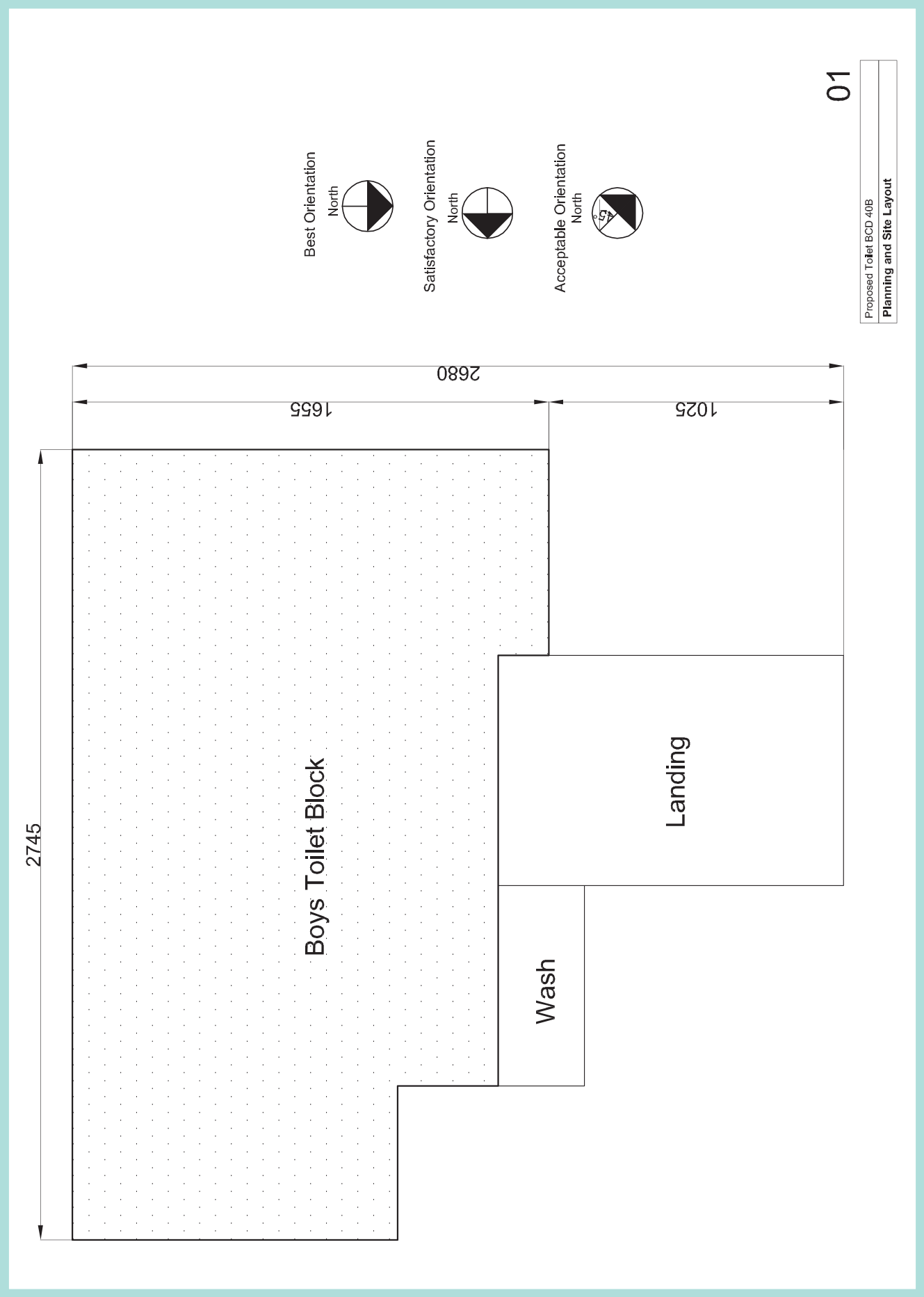

Notes

1. This design is valid for brick strength not below 35kg/sq.cm.
2. Foundation design is only indicative & may need review based on local site conditions.
3. For masonry water tank, the foundation shall be in 230mm brick up to the base of the tank.
4. Mortar 1:4 for 115mm thick masonry. No reinforcement bars in alternate courses.
5. This design is valid for earth quake zone I, II & III only
6. No water supply or waste water carrying pipe shall be concealed in the masonry wall. It shall be exposed and fixed with clips and not chased in masonry walls.
7. In case the masonry specification is changed from that given here, maintain the internal clear dimensions & the layout and provide suitable redesigned foundation.
8. Sloping roof overhang and its anchorage design may need review in cyclone prone regions.
9. In case roof specifications are changed from that given here (e.g. flat roof in stone or RCC) provide suitable strengthening of masonry while maintaining all internal clearances in the layout design.
10. Location of leach pits, soak pits, waste drainage pipes & inspection chamber is indicative only. Actual location to be decided based on site conditions.
11. Minimum distance of leaching pit from building foundation to be 125cm in different soil types.
12. Design of leach pit shown is for 40 children with its volume sufficient for catering approximately two years in different soil types. For higher capacity or longer duration, design will need review.

Key to symbols:

1. --- Pipe carrying waste water from wash area to flush urinals.
2. - - - Open / Covered drain for waste from Urinal / Squatting pan.
3. Masonry wall.
4. Roof line

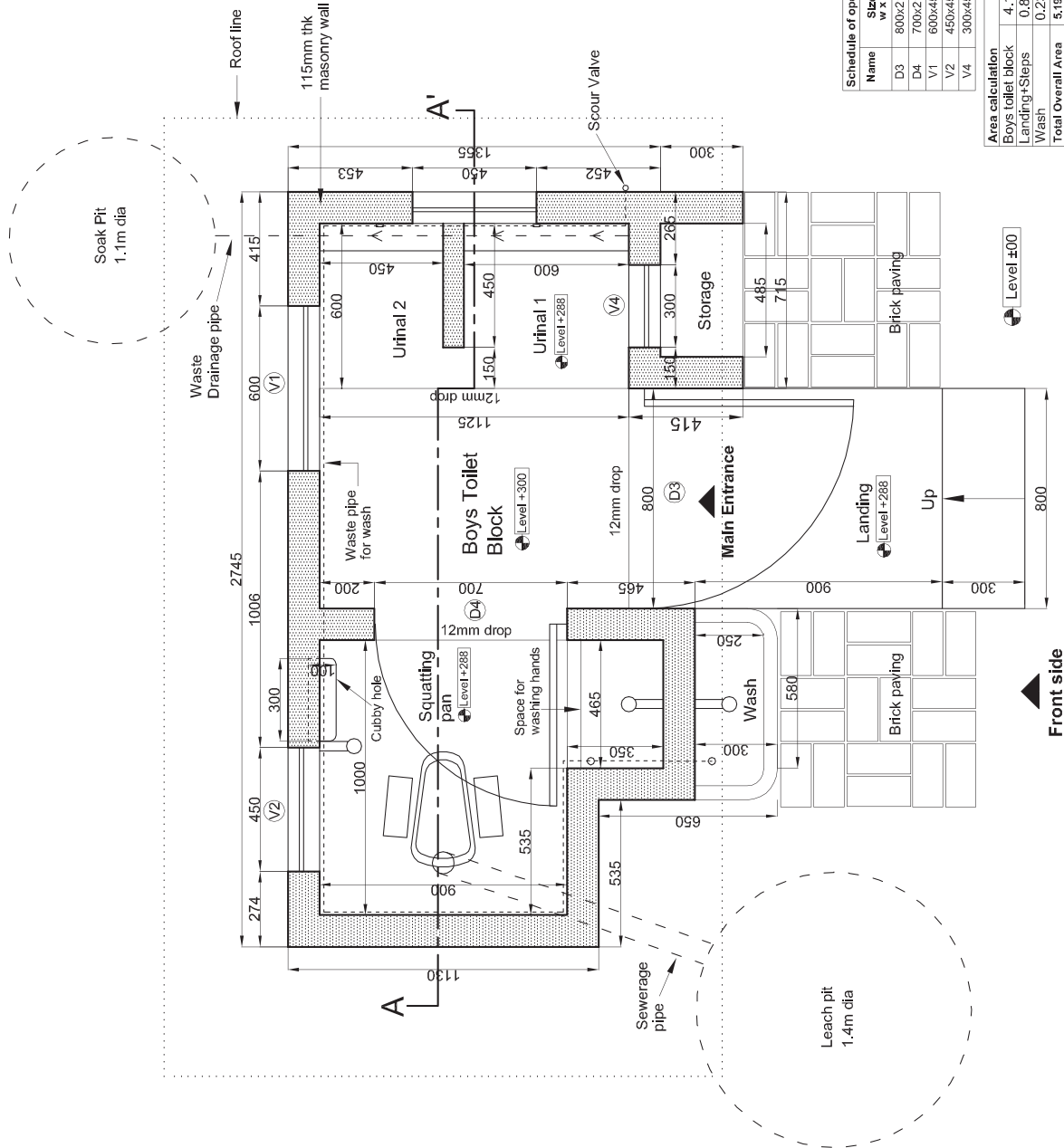

Schedule of openings	
Name	Size
D3	800x2100
D4	700x2100
V1	600x450
V2	450x450
V4	300x450

Area calculation	
Boys toilet block	4.14 sqm
Landing+Steps	0.82 sqm
Wash	0.23 sqm
Total Overall Area	5.19 sqm
Total Covered Area	4.37 sqm

Level ±00

Front side

Proposed Toilet BCD 40B

Plan

Scale: 1:100

All dimensions are in mm

01

Section & Details – 01 BCD 40 B

Suggested brief specifications:

- Civil work**
1. Pre-construction chemical termite treatment as per need.
 2. PCC 1:3:6 Cement: Coarse Sand: Coarse Aggregate in foundation.
 3. Foundation and Plinth in 1:4 cement mortar in brickwork.
 4. 75mm thick plinth band in 1:2:4 Reinforced Cement Concrete.
 5. Superstructure masonry in 1:4 cement mortar in 115 mm thick brick work.
 6. Pointing in 1:4 on exterior face.
 7. All urinals and squatting pan area with ceramic tile floor and dado up to 750mm from finished floor.
 8. Use of waterproofing compound for plaster upto dado level and for flooring tile.
 9. All other flooring in cement concrete / stone tile as per availability. Slope in toilets & urinals floor is 1:50.
 10. 115mm thick lintel band in 1:2:4 Reinforced Cement Concrete.
 11. Built-in water tank with masonry walls and lining of waterproof cement plaster.
 12. Sloping roof in MCR / Country tile / Mangalore tile with metal / timber under-structure.
 13. Roof under-structure to be tied to masonry/linel band as per detail given.
 14. Door and ventilator frame in metal angle sections, painted with two coat of primer before installation.
 15. Door shutter in PVC/metal painted with two coats of primer and painted with enamel paint in light colour.

Plumbing and Sanitary work

17. All plumbing pipes in B class GI pipes with suitable elbow / tee / nipple / union / scour valves.
18. All taps of best quality, locally available.
19. All waste water carrying pipes in HDPE / PVC to flush urinals.
20. All girls urinals squatting type in glazed ceramic type, white in colour.
21. All squatting pan of rural pan type in glazed ceramic type, white in colour.
22. All drainage and sewage pipes from Urinals / Squatting pan area in HDPE / PVC / CI / SW as per local availability.
23. Leach pit with 115mm thick honeycomb brickwork in 1:4 cement sand mortar.

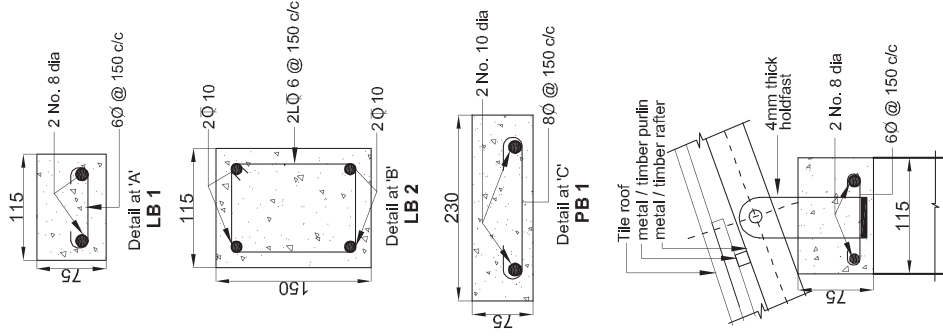

LB1 with roof anchorage detail

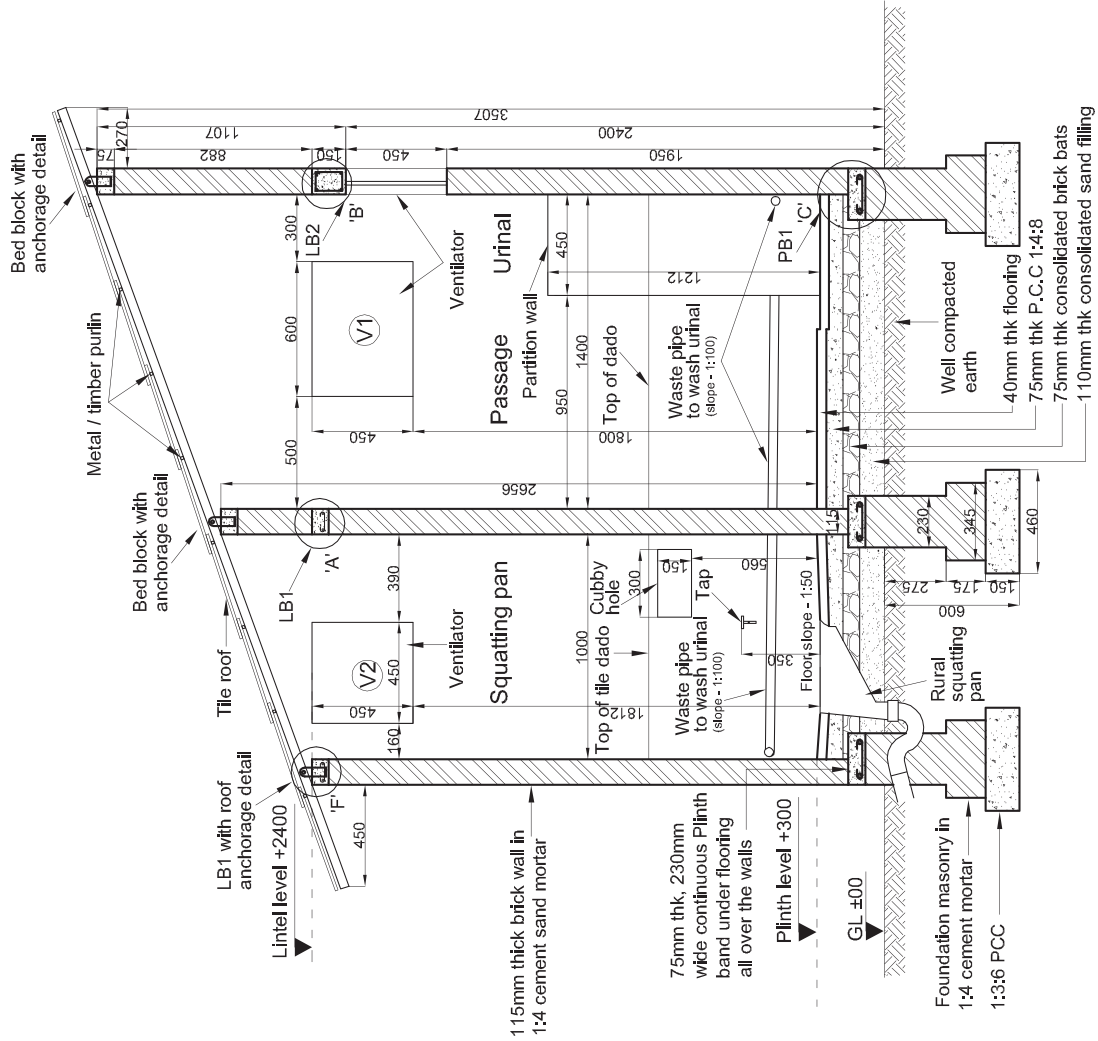

Section AA

Schedule of openings	
Name	Size w x h
D3	800x2100
D4	700x2100
V1	600x450
V2	450x450
V4	300x450

Proposed Toilet BCD 40B

Section and Details

Scale



All dimensions are in mm

01

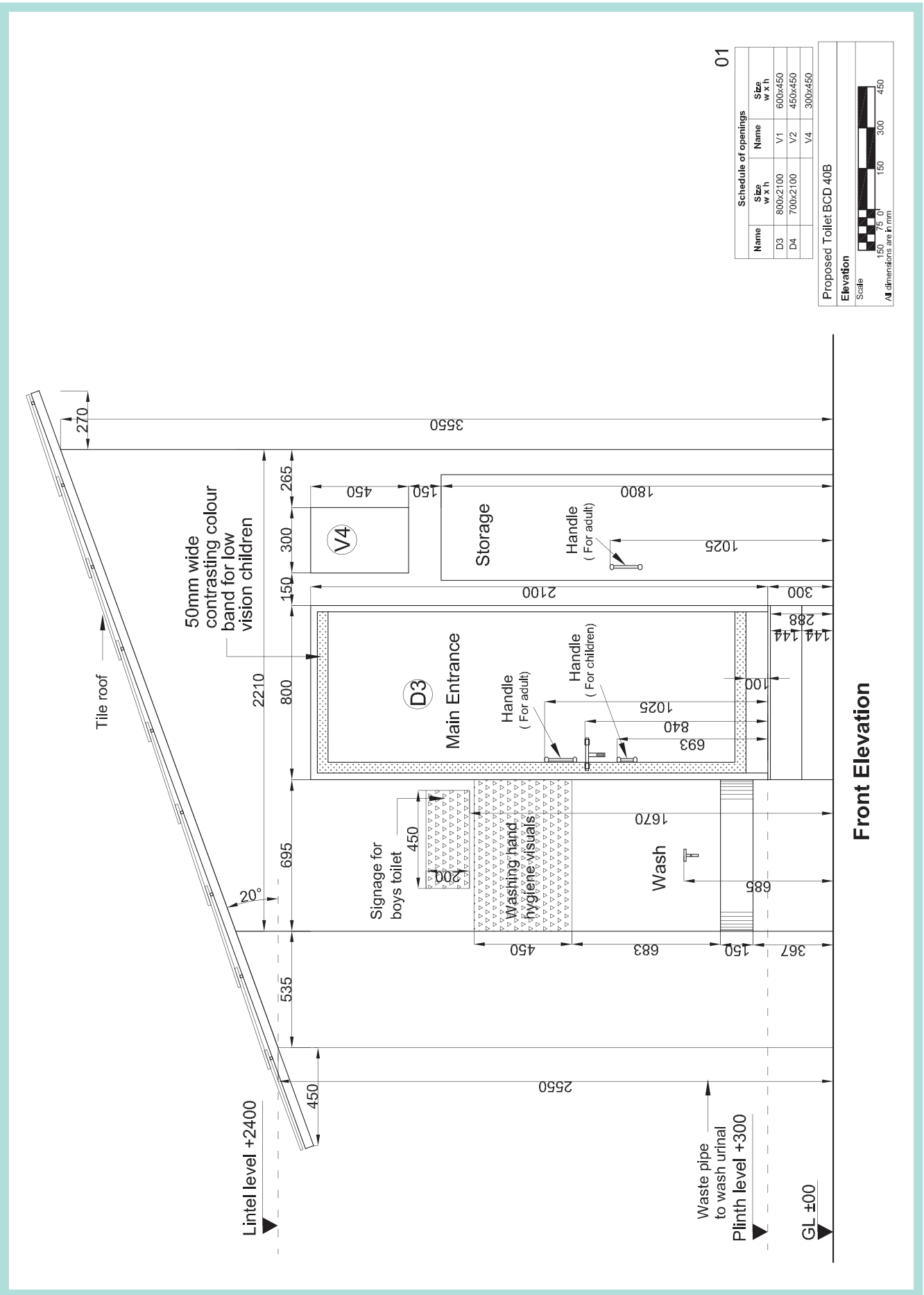

01

Schedule of openings			
Name	Size w x h	Name	Size w x h
D3	800x2100	V1	600x450
D4	700x2100	V2	450x450
		V4	300x450

Proposed Toilet BCD 40B

Elevation

Scale



All dimensions are in mm

Front Elevation

Bill of quantities – 01 BCD 40 B

ITEM	UNIT	Quantity	Rate	Indexed rate	Amount
1 Excavation					
a Foundation	cu.m	2.8831	30.00	35.4	102.06
b Leach and soak pit	cu.m	4.2076	30.00	35.4	148.95
c Ramp work	cu.m		30.00	35.4	
2 PCC					
a 1:3:6 PCC in foundation	cu.m	0.6862	1678.00	1980.04	1358.71
b 1:4:8 PCC in flooring	cu.m	0.3470	1503.60	1774.25	615.67
c 1:4:8 PCC in Ramp	cu.m		1503.60	1774.25	
3 Back-filling					
a Foundation	cu.m	0.8254	25.55	30.15	24.89
b Sand fill under floor	cu.m	0.2030	95.60	112.81	22.90
c Consolidated aggregate under floor	cu.m	0.2088		0.00	0.00
d Infill in soak pit	cu.m	1.8997	25.55	30.15	57.27
e Back fill in Ramp	cu.m		25.55	30.15	
4 Brick work					
a Brickwork in foundation and plinth	cu.m	1.4221	1452.9	1714.42	2438.14
b Brickwork in Ramp	cu.m		1452.90	1714.42	
c Honey comb brickwork in leach pit	sq.m	6.054	216.45	255.41	1546.26
d 75mm thk masonry partition in superstructure	sq.m	0.7613	119.4	140.89	107.25
e 115mm thick masonry in superstructure	sq.m	22.7005	199.00	234.82	5330.53
f 230mm thick masonry in superstructure	cu.m		1690.45	1994.73	
g Brick work in steps	cu.m	0.2707	1690.45	1994.73	539.97
h Dry brick work in paving	sq.m	1.0529	80.85	95.40	98.54
5 RCC work					
a 1:2:4 RCC Plinth band	cu.m	0.1711	5209.75	6147.51	1051.56
b 1:2:4 RCC Lintel band (all types)	cu.m	0.122	5209.75	6147.51	750.00
c 1:2:4 PCC bed blocks for roof anchorage	cu.m	0.0179	2136.35	2520.89	45.01
6 Slab (Stone / precast RCC)					
a 125mm thk Slab under water tank	sq.m		570.79	673.53	
b 75mm thk Slab under hand wash areas (all)	sq.m	0.4693	342.47	404.11	189.63
c 50mm thk Partition shelves in storage	sq.m	0.6143	228.31	269.41	165.48
d 75mm thk Cover for water tank	sq.m		342.47	404.11	
e 75mm thk Cover for leach pit	sq.m	1.5386	342.47	404.11	621.77
7 Pointing and plastering					
a 1:4 pointing in exposed brick work	sq.m	20.3738	29.75	35.11	715.22
b 1:6 cement sand plastering	sq.m	20.4729	39.90	47.08	963.91
c 1:6 cement sand with waterproof plastering	sq.m	0.9188	32.73	38.62	35.48
8 Flooring					
a Cement concrete flooring	sq.m	1.8925	143.85	169.74	321.24

cu.m – Cubic meter, sq.m – Square meter, m.m – Running meter

ITEM	UNIT	Quantity	Rate	Indexed rate	Amount
9 Tile work					
a Ceramic tile work in floor	sq.m	1.7042	504.10	594.84	1013.72
b Ceramic tile work in dado	sq.m	5.26875	504.10	594.84	3134.05
c Antiskid tiles in Ramp	sq.m		406.15	479.26	
10 Sanitary fixtures					
a Rural squatting pan	number	1	350.00	413.00	413.00
b Girl's squatting urinal	number		300.00	354.00	
11 Plumbing					
a GI pipe water supply line (internal) +3m external	m.m	5.73	78.65	92.81	531.78
b Taps	number	3	250.00	295.00	885.00
c Waste water pipe for flushing	m.m	5.68	31.05	36.64	208.11
12 Sewage					
a Sewage line from squatting pan to first IC + 3m	m.m	4.013	111.60	131.69	528.46
b Waste drain line from urinal to first IC + 3m	m.m	3.3776	111.60	131.69	444.79
13 Roof work					
a Roof area (sloping, with overhangs and overlaps)	sq.m	7.4871	700.00	700.00	5240.97
14 Doors					
a D1	number		500.00	590.00	
b D2	number		500.00	590.00	
c D3	number	1	500.00	590.00	590.00
d D4	number	1	500.00	590.00	590.00
e D5	number		500.00	590.00	
f Storage door shutter	number	1	500.00	590.00	590.00
15 Ventilators					
a V1	number	1	350.00	413.00	413.00
b V2	number	2	350.00	413.00	826.00
c V3	number		350.00	413.00	
d V4	number	1	350.00	413.00	413.00
16 Incinerator					
a Metal / Masonry incinerator	number		1500.00	1500.00	
17 Painting work					
a Internal white washing	sq.m	20.4729	35.40	41.77	855.19
b External wall painting	sq.m	20.3738	30.00	35.40	721.23
c Door and ventilator	sq.m	8.7105	58	68.44	596.15
18 Metal Work					
a Grab bars in toilets 40mm dia MS pipe	m.m		32.10	37.88	
b Rail in 40mm dia MS pipe in ramp	m.m		32.10	37.88	
c Vertical rail supports 25mm dia MS bars	m.m		32.10	37.88	

Total Amount Rs. 35245
Total Area Sq.m 4.37
Cost per sqm 8065

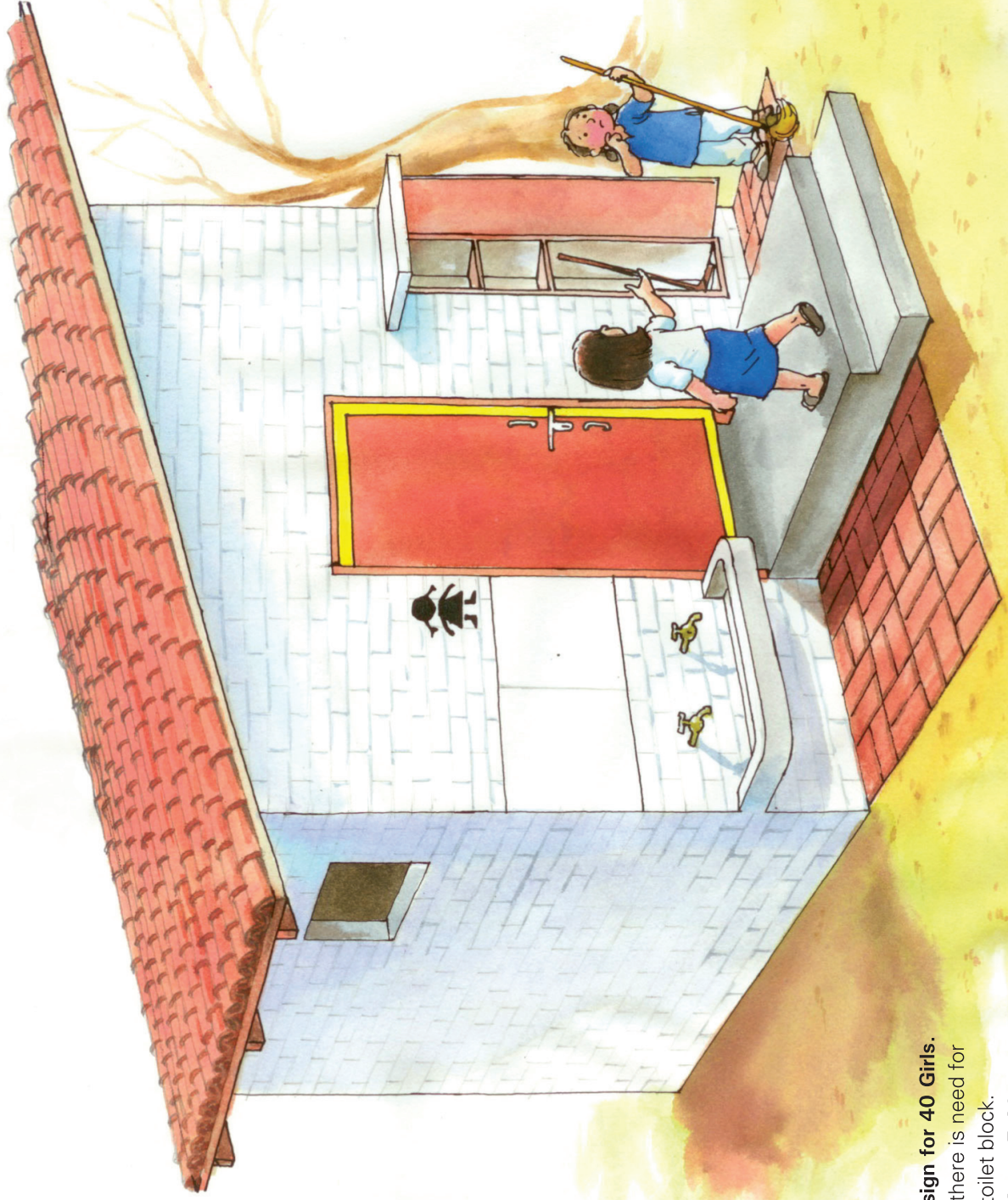

Basic Core Design for 40 Girls.
Suitable when there is need for separate girl's toilet block.
Total Built-up Area: 5.41 sq.m
Indicative cost* Rs 45,294

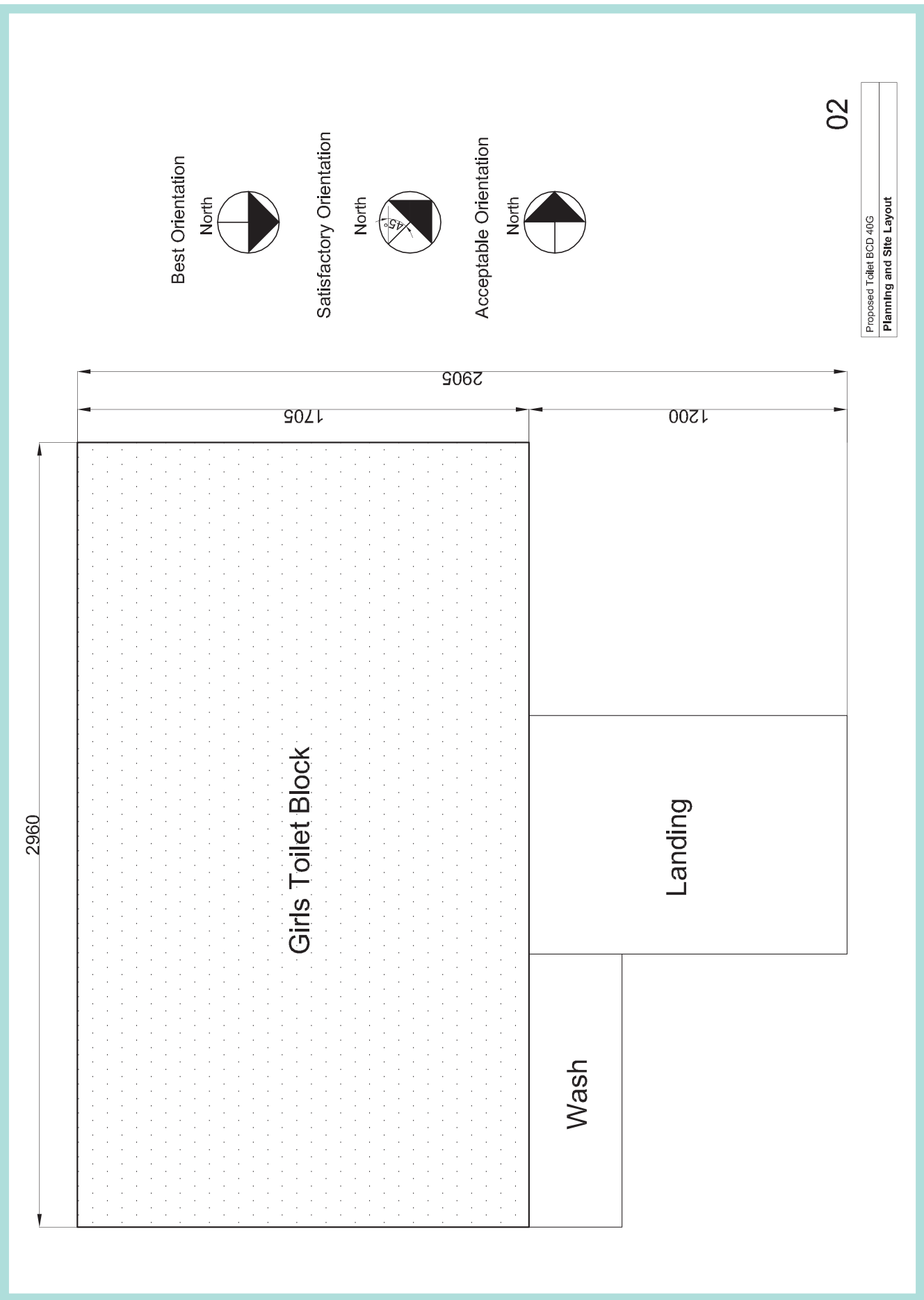

Notes

1. This design is valid for brick strength not below 35kg/sq.cm.
2. Foundation design is only indicative & may need review based on local site conditions.
3. For masonry water tank, the foundation shall be in 230mm brick up to the base of the tank.
4. Mortar 1:4 for 115mm thick masonry. No reinforcement bars in alternate courses.
5. This design is valid for earth quake zone I, II & III regions only.
6. No water supply or waste water carrying pipe shall be concealed in the masonry wall. It shall be exposed and fixed with clips and not chased in masonry walls.
7. In case the masonry specification is changed from that given here, maintain the internal clear dimensions and the layout and provide suitable redesigned foundation.
8. Sloping roof overhang and its anchorage design may need review in cyclone prone regions.
9. In case roof specifications are changed from that given here (e.g. flat roof in stone or RCC) provide suitable strengthening of masonry while maintaining all internal clearances in the layout design.
10. Only one metallic / masonry incinerator to be put along the location indicative as ICN.
11. Incinerator to be provided only with Girl's toilet and to have chute from inside.
12. Location of leach pits, soak pits, waste drainage pipes & inspection chamber is indicated only. Actual location to be decided based on site conditions.
13. Minimum distance of leaching pit from building foundation to be 125cm in different soil types.
14. Design of leach pit shown is for 40 children with its volume sufficient for catering approximately two years in different soil types. For higher capacity or longer duration, design will need review.

Key to symbols:

1. Pipe carrying waste water from wash area to flush urinals.
2. Open / Covered drain for waste from Urinal / Squatting pan.
3. Masonry wall.
4. Roof line.

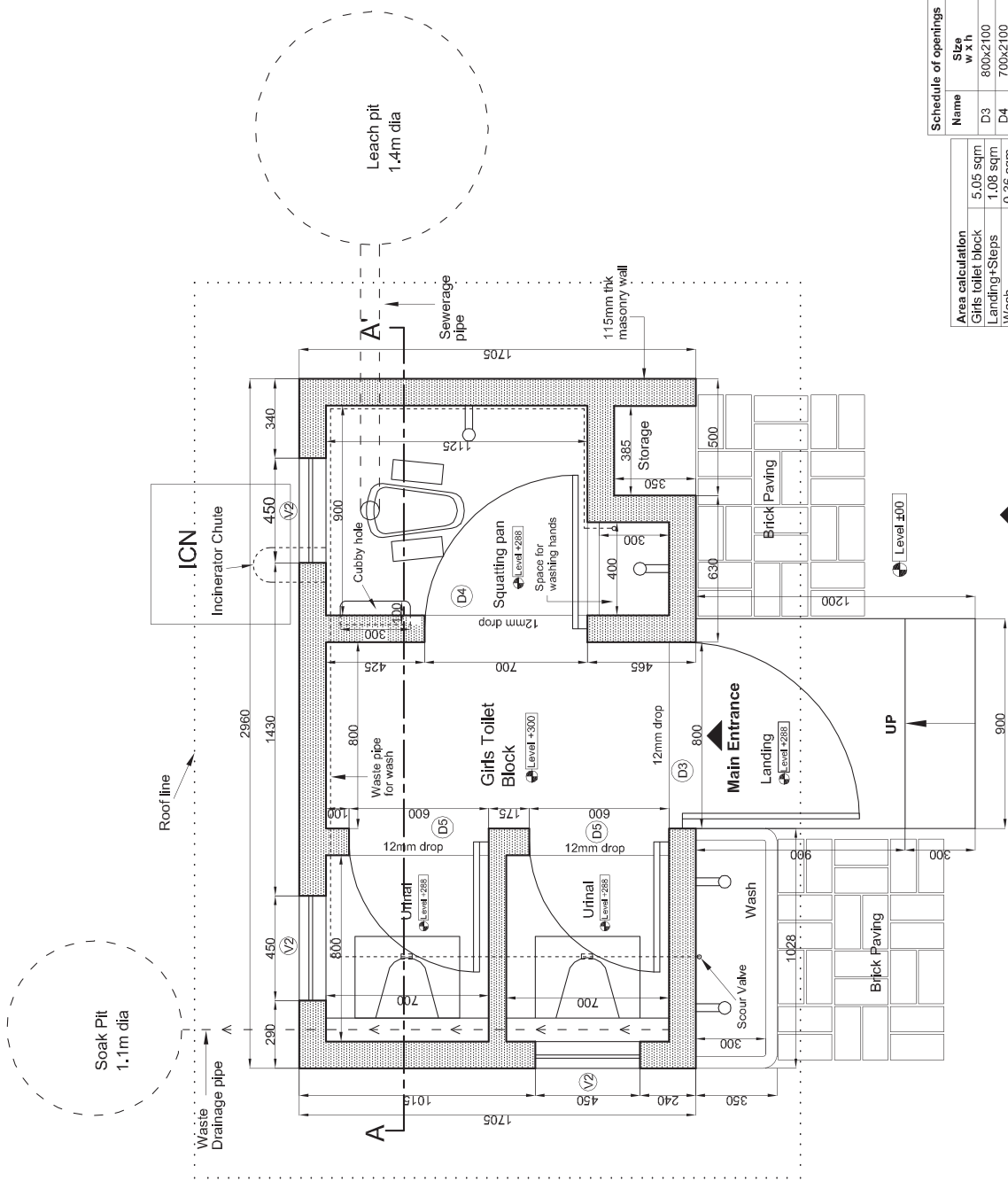

Schedule of openings

Name	Size w x h
D3	800x2100
D4	700x2100
D5	600x1500
V2	450x450

Area calculation	Size w x h
Girls toilet block	5.05 sqm
Landing+Steps	1.08 sqm
Wash	0.36 sqm
Total Overall Area	6.49 sqm
Total Covered Area	5.41 sqm

02

Proposed Toilet BCD 40G

Plan



Suggested brief specifications:

Civil work

1. Pre-construction chemical termite treatment as per need.
 2. PCC: 1:3:6 Cement: Coarse Sand: Coarse Aggregate in foundation.
 3. Foundation and Plinth in 1:4 cement mortar in brickwork.
 4. 75mm thick plinth band in 1:2:4 Reinforced Cement Concrete.
 5. Superstructure masonry in 1:4 cement mortar in 115 mm thick brick work.
 6. Pointing in 1:4 on exterior face.
 7. Plastering in 1:6 on interior face above dado level.
 8. All urinals and squatting pan area with ceramic tile floor and dado up to 750mm from finished floor.
 9. Use of waterproofing compound for plaster upto dado level and for fixing tile.
 10. All other flooring in cement concrete / stone tile as per availability. Slope in toilets & urinals floor is 1:50.
 11. 150mm thick Lintel band in 1:2:4 Reinforced Cement Concrete.
 12. Built-in water tank with masonry walls and lining of waterproof cement plaster.
 13. Sloping roof in MCF / Country tile / Mangalore tile with metal / timber under-structure.
 14. Roof under-structure to be fixed to masonry/plinth band as per detail given.
 15. Door and ventilator frame in metal angle sections, painted with two coats of primer before installation.
 16. Door shutter in PVC/metal painted with two coats of primer and painted with enamel paint in light colour.
- Plumbing and Sanitary work**
17. All plumbing pipes in B class GI pipes with suitable elbow / tee / nipple / union / scour valves.
 18. All taps of best quality, locally available.
 19. All waste water carrying pipes in HDPE / PVC to flush urinals.
 20. All gills urinals squatting type in glazed ceramic type, white in colour.
 21. All squatting pan of rural pan type in glazed ceramic type, white in colour.
 22. All drainage and sewage pipes from Urinals / Squatting pan area in HDPE / PVC / CI / SW as per local availability.
 23. Leach pit with 115mm thick honeycomb brickwork in 1:4 cement sand mortar.

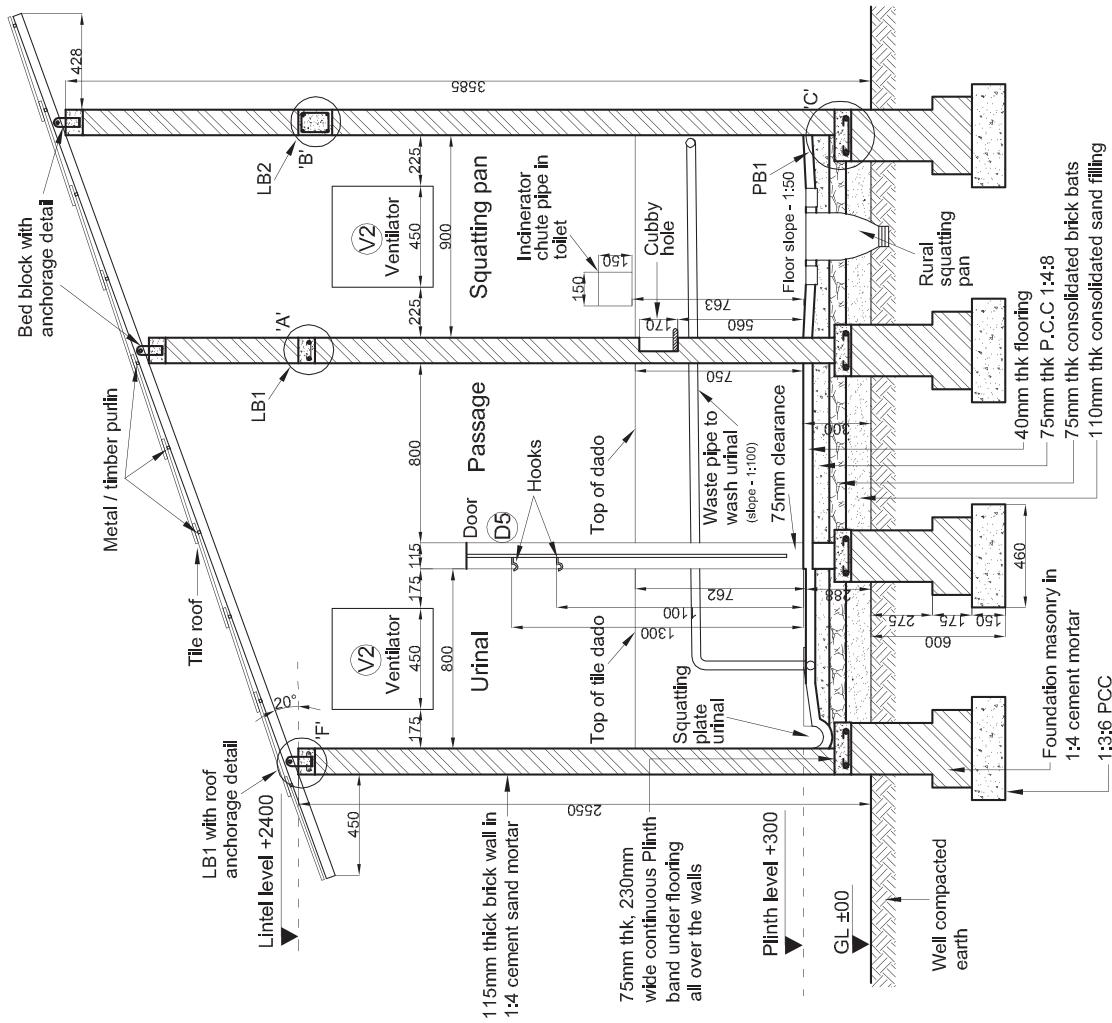
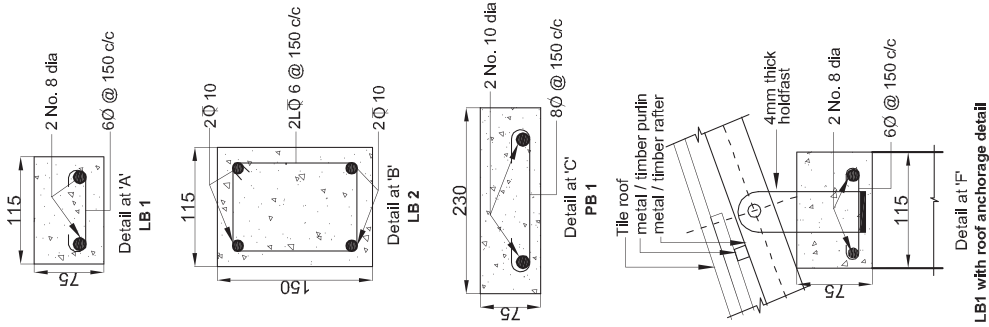

Schedule of openings

Name	Size
D3	800x2100
D4	700x2100
D5	600x1600
V2	450x450

Proposed Toilet BCD 40G

Section and Details

Scale: 1:10

All dimensions are in mm.

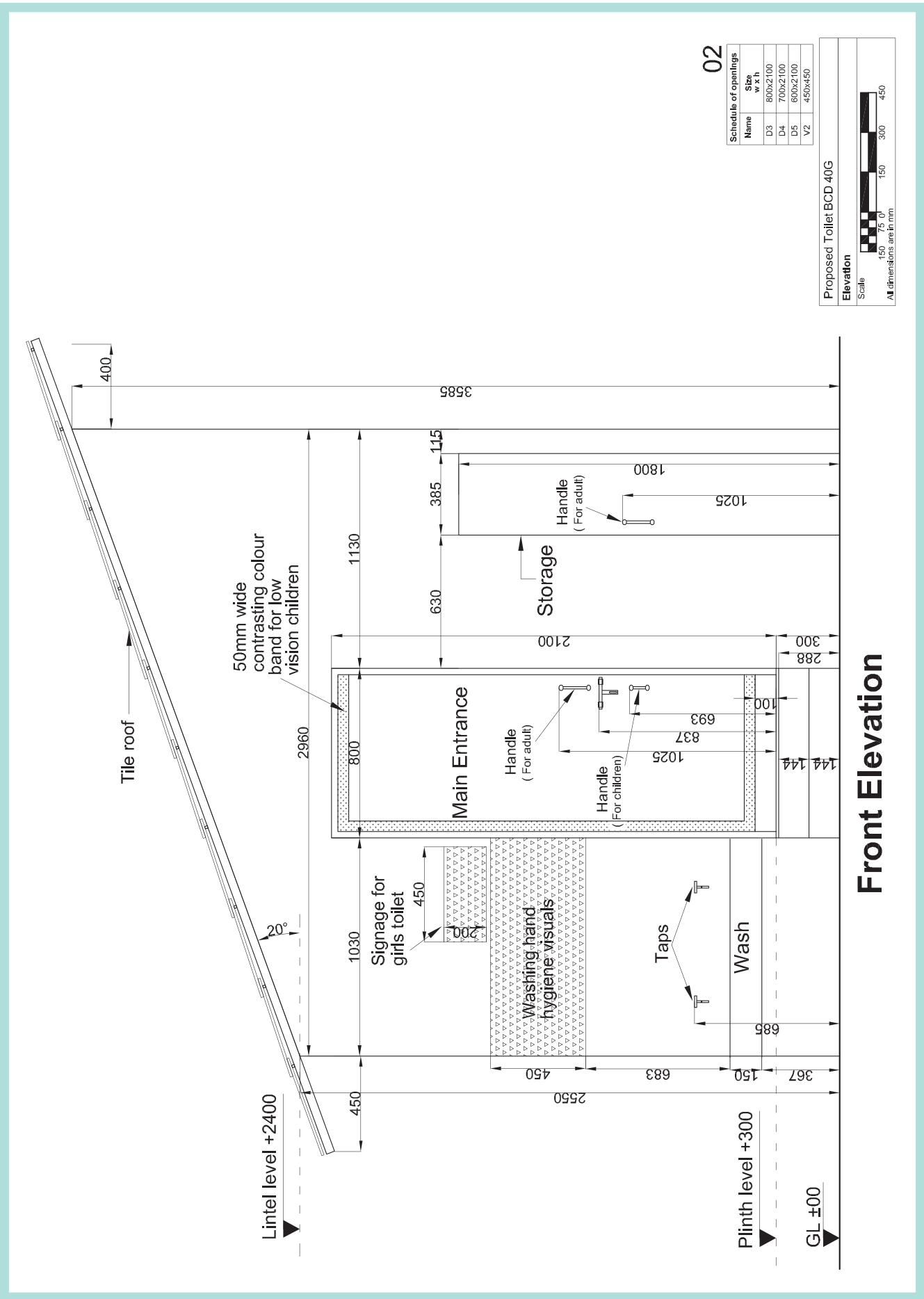

Bill of quantities – 02 BCD 40G

ITEM	UNIT	Quantity	Rate	Indexed rate	Amount
1 Excavation					
a Foundation	cu.m	3.5813	30.00	35.4	126.78
b Leach and soak pit	cu.m	4.2076	30.00	35.4	148.95
c Ramp work	cu.m		30.00	35.4	
2 PCC					
a 1:3:6 PCC in foundation	cu.m	0.8596	1678.00	1980.04	1701.98
b 1:4:8 PCC in flooring	cu.m	0.4120	1503.60	1774.25	731.03
c 1:4:8 PCC in Ramp	cu.m		1503.60	1774.25	
3 Back-filling					
a Foundation	cu.m	1.0340	25.55	30.15	31.17
b Sand fill under floor	cu.m	0.2720	95.60	112.81	30.68
c Consolidated aggregate under floor	cu.m	0.2690		0.00	0.00
d Infill in soak pit	cu.m	1.8997	25.55	30.15	57.27
e Back fill in Ramp	cu.m		25.55	30.15	
4 Brick work					
a Brickwork in foundation and plinth	cu.m	1.7814	1452.9	1714.42	3054.11
b Brickwork in Ramp	cu.m		1452.90	1714.42	
c Honey comb brickwork in leach pit	sq.m	6.0540	216.45	255.41	1546.26
d 75mm thk masonry partition in superstructure	sq.m	1.3725	119.4	140.89	193.37
e 115mm thick masonry in superstructure	sq.m	26.5122	199.00	234.82	6225.59
f 230mm thick masonry in superstructure	cu.m		1690.45	1994.73	
g Brick work in steps	cu.m	0.2722	1690.45	1994.73	542.89
h Dry brick work in paving	sq.m	1.4084	80.85	95.40	134.37
5 RCC work					
a 1:2:4 RCC Plinth band	cu.m	0.2143	5209.75	6147.51	1317.22
b 1:2:4 RCC Lintel band (all types)	cu.m	0.1514	5209.75	6147.51	930.73
c 1:2:4 PCC bed blocks for roof anchorage	cu.m	0.0179	2136.35	2520.89	45.01
6 Slab (Stone / precast RCC)					
a 125mm thk Slab under water tank	sq.m		570.79	673.53	
b 75mm thk Slab under hand wash areas (all)	sq.m	0.6112	342.47	404.11	246.99
c 50mm thk Partition shelves in storage	sq.m	0.5820	228.31	269.41	156.79
d 75mm thk Cover for water tank	sq.m		342.47	404.11	
e 75mm thk Cover for leach pit	sq.m	1.5386	342.47	404.11	621.77
7 Pointing and plastering					
a 1:4 pointing in exposed brick work	sq.m	20.8688	29.75	35.11	732.60
b 1:6 cement sand plastering	sq.m	23.9772	39.90	47.08	1128.89
c 1:6 cement sand with waterproof plastering	sq.m	1.4550	32.73	38.62	56.19
8 Flooring					
a Cement concrete flooring	sq.m	2.3005	143.85	169.74	390.49

cu.m – Cubic meter, sq.m – Square meter, m.m – Running meter

ITEM	UNIT	Quantity	Rate	Indexed rate	Amount
9 Tile work					
a Ceramic tile work in floor	sq.m	2.2725	504.10	594.84	1351.77
b Ceramic tile work in dado	sq.m	6.6375	504.10	594.84	3948.24
c Antiskid tiles in Ramp	sq.m		406.15	479.26	
10 Sanitary fixtures					
a Rural squatting pan	number	1	350.00	413.00	413.00
b Girl's squatting urinal	number	2	300.00	354.00	708.00
11 Plumbing					
a GI pipe water supply line (internal) +3m external	m.m	6.564	78.65	92.81	609.19
b Taps	number	4	250.00	295.00	1180.00
c Waste water pipe for flushing	m.m	6.211	31.05	36.64	227.56
12 Sewage					
a Sewage line from squatting pan to first IC + 3m	m.m	4.1438	111.60	131.69	545.69
b Waste drain line from urinal to first IC + 3m	m.m	3.6189	111.60	131.69	476.57
13 Roof work					
a Roof area (sloping, with overhangs and overlaps)	sq.m	10.6388	700.00	700.00	7447.16
14 Doors					
a D1	number		500.00	590.00	
b D2	number		500.00	590.00	
c D3	number	1	500.00	590.00	590.00
d D4	number	1	500.00	590.00	590.00
e D5	number	2	500.00	590.00	1180.00
f Storage door shutter	number	1	500.00	590.00	590.00
15 Ventilators					
a V1	number		350.00	413.00	0.00
b V2	number	3	350.00	413.00	1239.00
c V3	number		350.00	413.00	
d V4	number		350.00	413.00	0.00
16 Incinerator					
a Metal / Masonry incinerator	number	1	1500.00	1500.00	1500.00
17 Painting work					
a Internal white washing	sq.m	23.9772	35.40	41.77	1001.58
b External wall painting	sq.m	20.8688	30.00	35.40	738.76
c Door and ventilator	sq.m	11.778	58	68.44	806.09
18 Metal Work					
a Grab bars in toilets 40mm dia MS pipe	m.m		32.10	37.88	
b Rail in 40mm dia MS pipe in ramp	m.m		32.10	37.88	
c Vertical rail supports 25mm dia MS bars	m.m		32.10	37.88	

Total Amount Rs. 45294
Total Area Sq.m 5.41
Cost per sqm 8372

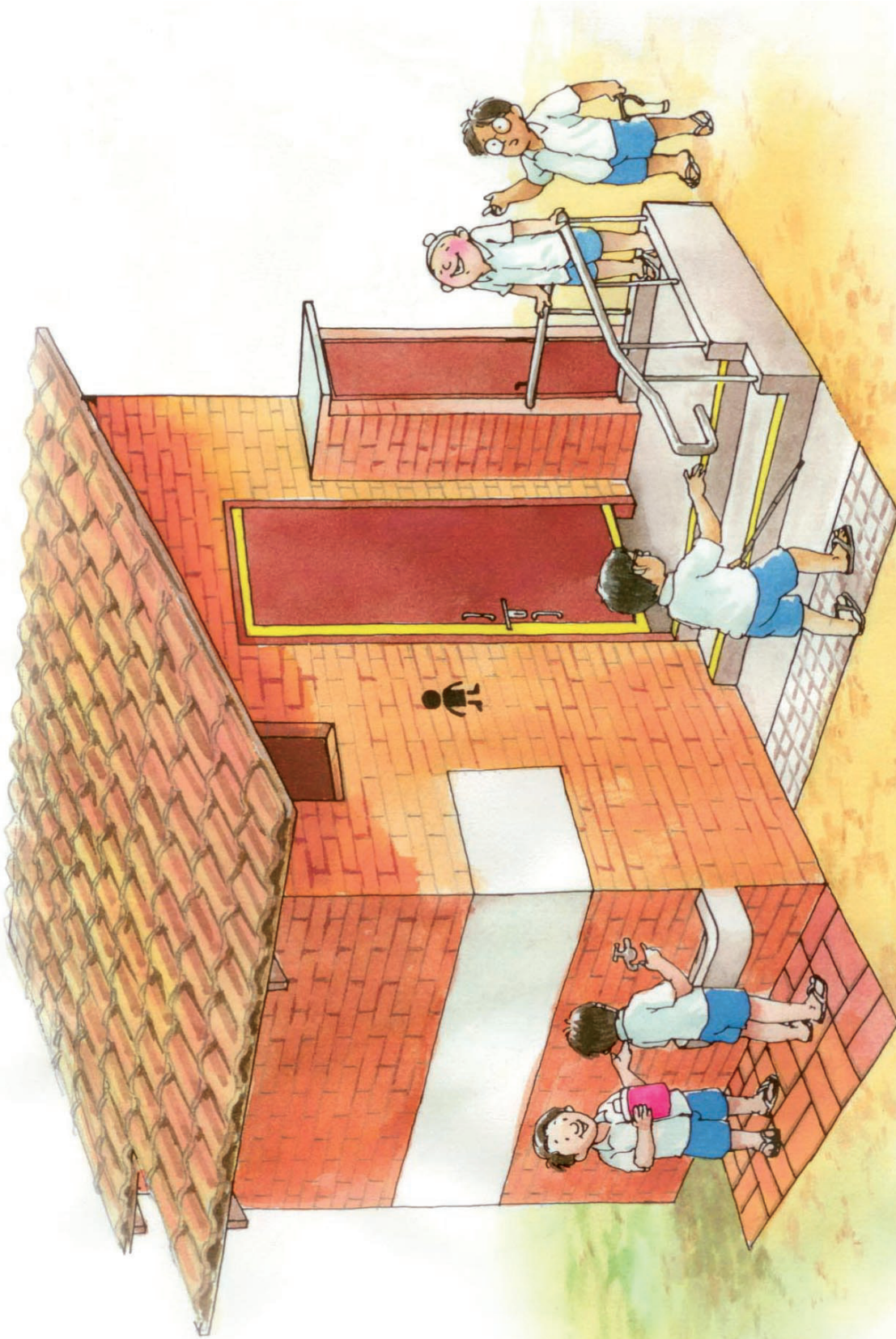

Basic Core Design for 80 Boys.
Suitable when there is need for separate boy's toilet block.
Total Built-up Area: 5.08 sq.m
Indicative cost* Rs 41, 712

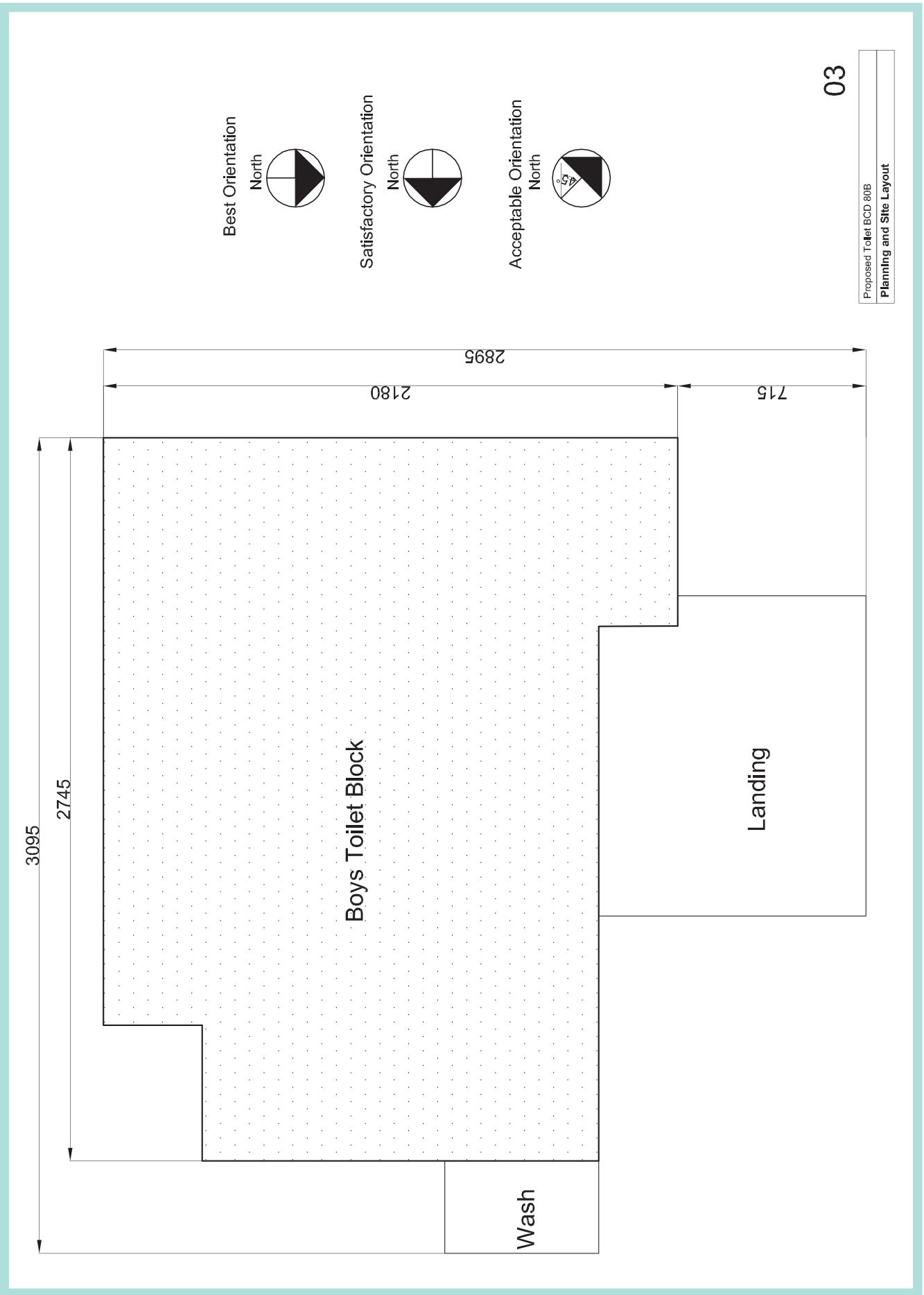

Notes

1. This design is valid for brick strength not below 35kg/sq.cm.
2. Foundation design is only indicative & may need review based on local site conditions.
3. For masonry water tank, the foundation shall be in 230mm brick up to the base of the tank.
4. Mortar 1:4 for 115mm thick masonry. No reinforcement bars in alternate courses.
5. This design is valid for earth quake zone I, II & III only
6. No water supply or waste water carrying pipe shall be concealed in the masonry wall. It shall be exposed and fixed with clips and not chased in masonry walls.
7. In case the masonry specification is changed from that given here, maintain the internal clear dimensions and the layout and provide suitable redesigned foundation.
8. Sloping roof overhang and its anchorage design may need review in cyclone prone regions.
9. In case roof specifications are changed from that given here (e.g. flat roof in stone or RCC) provide suitable strengthening of masonry while maintaining all internal clearances in the layout design.
10. Location of leach pits, soak pits, waste drainage pipes & inspection chamber is indicative only. Actual location to be decided based on site conditions.
11. Minimum distance of leaching pit from building foundation to be 125cm in different soil types.
12. Design of leach pit shown is for 80 children with its volume sufficient for catering approximately one year in different soil types. For higher capacity or longer duration, design will need review.

Key to symbols:

1. Pipe carrying waste water from wash area to flush urinals.
2. Open / Covered drain for waste from Urinal / Squatting pan.
3. Masonry wall.
4. Roof line

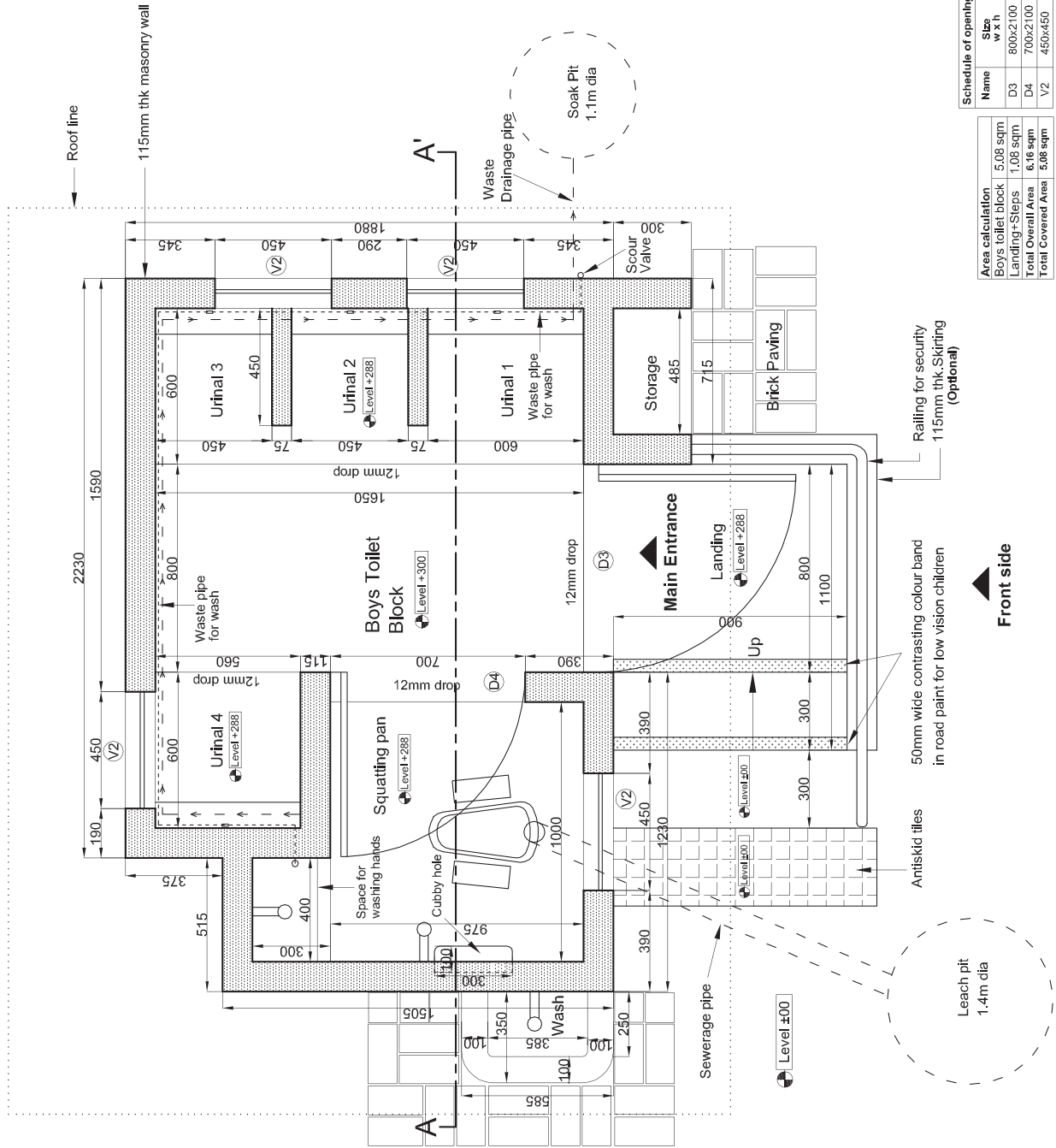

Schedule of openings

Name	Size w x h
D3	800x2100
D4	700x2100
V2	450x450

Area calculation

Boys toilet block	5.08 sqm
Landing+Steps	1.08 sqm
Total Overall Area	6.16 sqm
Total Covered Area	5.08 sqm

Proposed Toilet BCD 80B

Plan

Scale: 1:100

All dimensions are in mm

03

Section & Details – 03 BCD 80B

Suggested brief specifications:

- Civil work**
1. Pre-construction chemical termite treatment as per need.
 2. PCC 1:3:6 Cement: Coarse Sand: Coarse Aggregate in foundation.
 3. Foundation and Plinth in 1:4 cement mortar in brickwork.
 4. 75mm thick plinth band in 1:2:4 Reinforced Cement Concrete.
 5. Superstructure masonry in 1:4 cement mortar in 115 mm thick brick work.
 6. Pointing in 1:4 on exterior face.
 7. Plastering in 1:6 on interior face above dado level.
 8. All urinals and squatting pan area with ceramic tile floor and dado up to 750mm from finished floor.
 9. Use of waterproofing compound for plaster upto dado level and for fixing tile.
 10. All other flooring in cement concrete / stone tile as per availability. Slope in toilets & urinals floor is 1:50.
 11. 150mm thick lintel band in 1:2:4 Reinforced Cement Concrete.
 12. Built-in water tank with masonry walls and lining of waterproof cement plaster.
 13. Sloping roof in MCR / Country tile / Mangalore tile with metal / timber under-structure.
 14. Roof under-structure to be tied to masonry / lintel band as per detail given.
 15. Door and ventilator frame in metal angle sections, painted with two coat of primer before installation.
 16. Door shutter in PVC/metal painted with two coats of primer and painted with enamel paint in light colour.

Plumbing and Sanitary work

17. All plumbing pipes in B class GI pipes with suitable elbow / tee / nipple / union / scour valves.
18. All taps of best quality, locally available.
19. All waste water carrying pipes in HDPE / PVC to flush urinals.
20. All girls urinals squatting type in glazed ceramic type, white in colour.
21. All squatting pan of rural pan type in glazed ceramic type, white in colour
22. All drainage and sewage pipes from Urinals / Squatting pan area in HDPE / PVC / CI / SW as per local availability.
23. Leach pit with 115mm thick honeycomb brickwork in 1:4 cement sand mortar

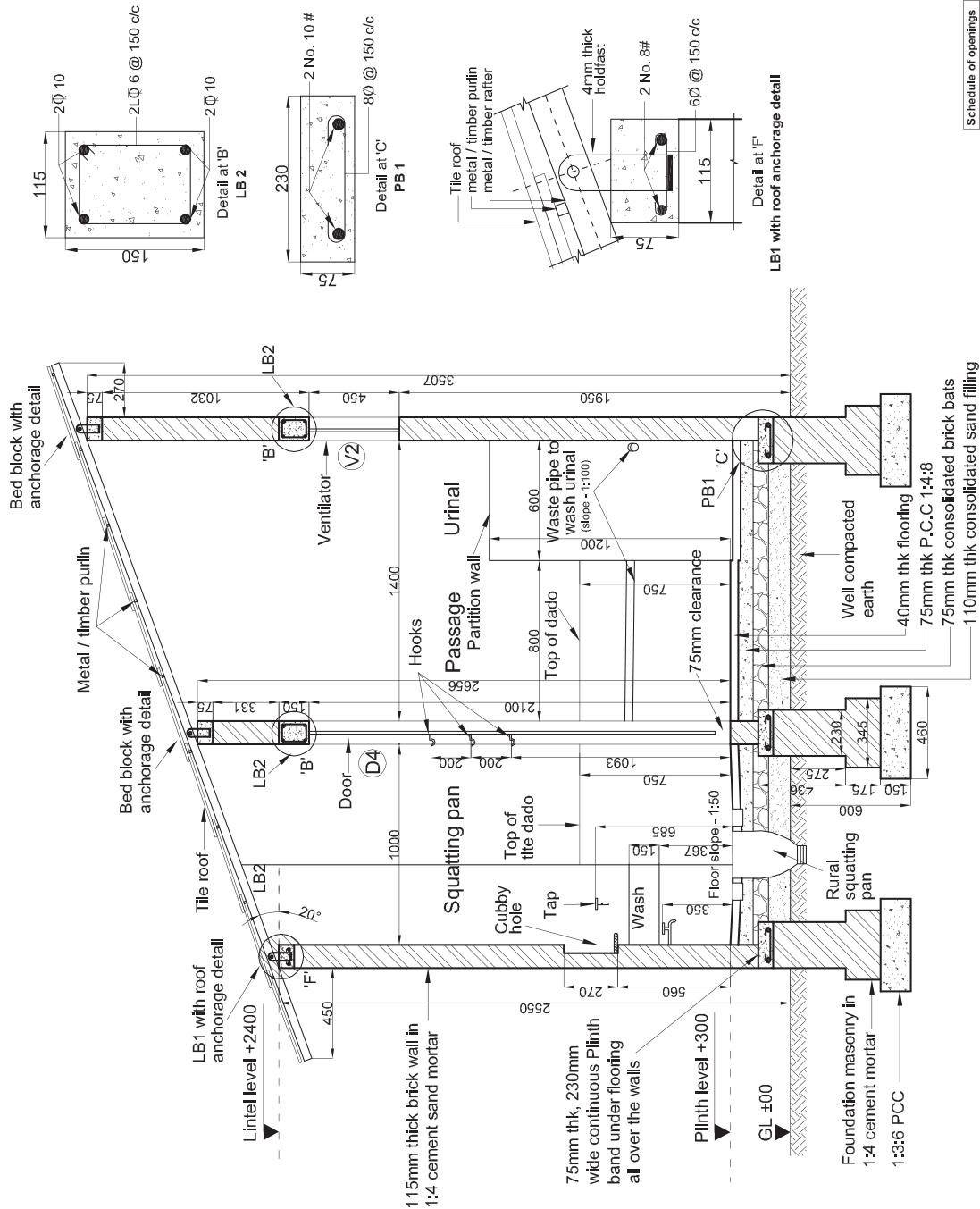

Section AA'

Schedule of openings	
Name	Size w x h
D3	800x2100
D4	700x2100
V2	450x450

03

Proposed Toilet BCD 80B

Section and Details

Scale



All dimensions are in mm

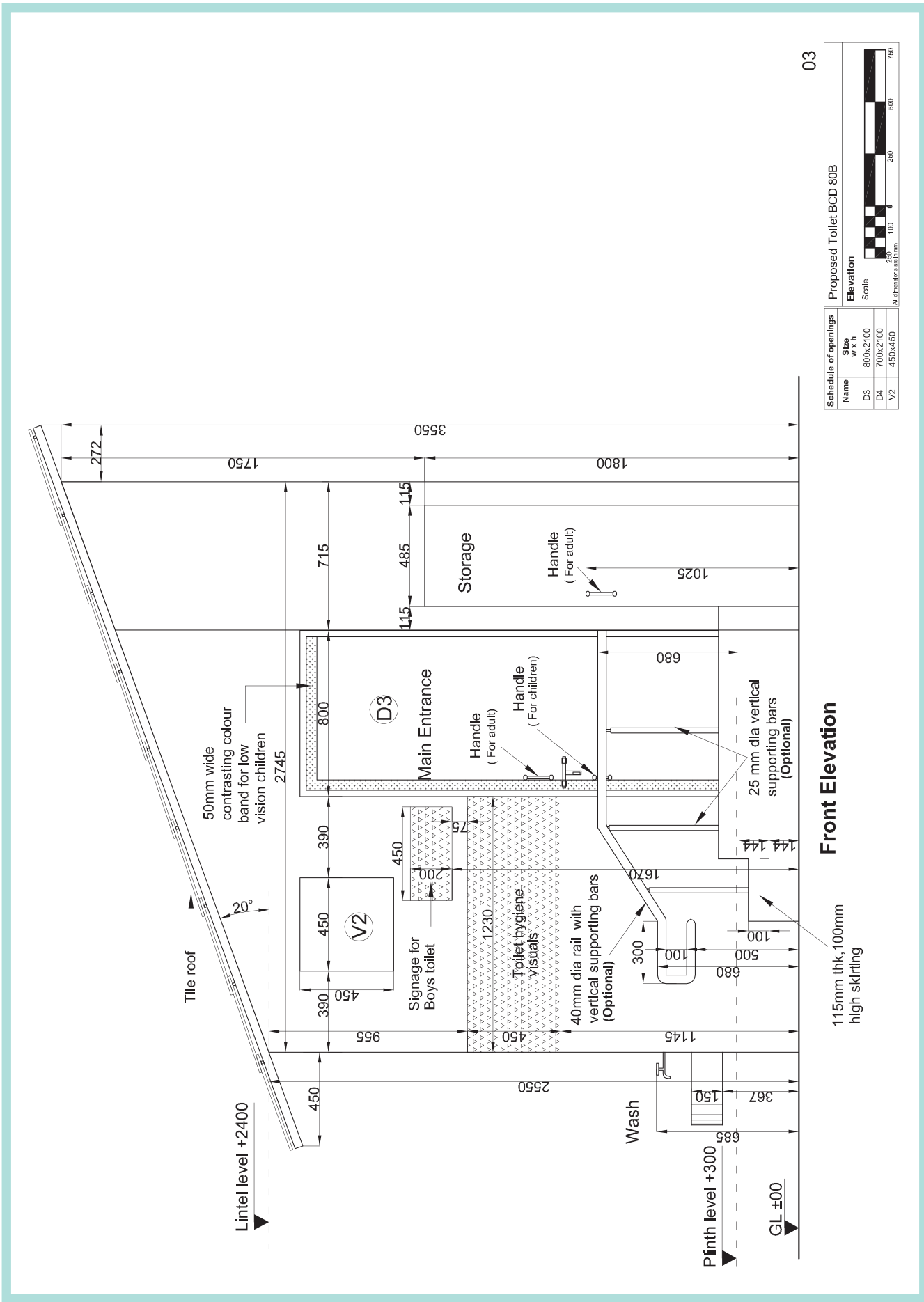

Front Elevation

Schedule of openings		Proposed Toilet BCD 80B	
Name	Size w x h	Elevation	Scale
D3	800x2100		
D4	700x2100		
V2	450x450		

115mm thk, 100mm high skirting

03

Bill of quantities – 03 BCD 80B

ITEM	UNIT	Quantity	Rate	Indexed rate	Amount
1 Excavation					
a Foundation	cu.m	3.3239	30.00	35.4	117.67
b Leach and soak pit	cu.m	4.2076	30.00	35.4	148.95
c Ramp work	cu.m		30.00	35.4	
2 PCC					
a 1:3:6 PCC in foundation	cu.m	0.7932	1678.00	1980.04	1570.48
b 1:4:8 PCC in flooring	cu.m	0.4319	1503.60	1774.25	766.29
c 1:4:8 PCC in Ramp	cu.m		1503.60	1774.25	
3 Back-filling					
a Foundation	cu.m	0.9541	25.55	30.15	28.76
b Sand fill under floor	cu.m	0.2978	95.60	112.81	33.60
c Consolidated aggregate under floor	cu.m	0.2806		0.00	0.00
d Infill in soak pit	cu.m	1.8997	25.55	30.15	57.27
e Back fill in Ramp	cu.m		25.55	30.15	
4 Brick work					
a Brickwork in foundation and plinth	cu.m	1.6438	1452.9	1714.42	2818.14
b Brickwork in Ramp	cu.m		1452.90	1714.42	
c Honey comb brickwork in leach pit	sq.m	6.0540	216.45	255.41	1546.26
d 75mm thk masonry partition in superstructure	sq.m	1.5225	119.4	140.89	214.51
e 115mm thick masonry in superstructure	sq.m	27.0039	199.00	234.82	6341.06
f 230mm thick masonry in superstructure	cu.m		1690.45	1994.73	
g Brick work in steps	cu.m	0.3291	1690.45	1994.73	656.47
h Dry brick work in paving	sq.m	1.0456	80.85	95.40	99.75
5 RCC work					
a 1:2:4 RCC Plinth band	cu.m	0.1977	5209.75	6147.51	1215.45
b 1:2:4 RCC Lintel band (all types)	cu.m	0.1358	5209.75	6147.51	834.83
c 1:2:4 PCC bed blocks for roof anchorage	cu.m	0.0179	2136.35	2520.89	45.01
6 Slab (Stone / precast RCC)					
a 125mm thk Slab under water tank	sq.m		570.79	673.53	
b 75mm thk Slab under hand wash areas (all)	sq.m	0.4000	342.47	404.11	161.65
c 50mm thk Partition shelves in storage	sq.m	0.6143	228.31	269.41	165.48
d 75mm thk Cover for water tank	sq.m		342.47	404.11	
e 75mm thk Cover for leach pit	sq.m	1.5386	342.47	404.11	621.77
7 Pointing and plastering					
a 1:4 pointing in exposed brick work	sq.m	21.8273	29.75	35.11	766.25
b 1:6 cement sand plastering	sq.m	22.3389	39.90	47.08	1051.76
c 1:6 cement sand with waterproof plastering	sq.m	0.9675	32.73	38.62	37.37
8 Flooring					
a Cement concrete flooring	sq.m	2.2181	143.85	169.74	376.51

cu.m – Cubic meter, sq.m – Square meter, m.m – Running meter

ITEM	UNIT	Quantity	Rate	Indexed rate	Amount
9 Tile work					
a Ceramic tile work in floor	sq.m	2.281	504.10	594.84	1356.83
b Ceramic tile work in dado	sq.m	7.6575	504.10	594.84	4554.97
c Antiskid tiles in Ramp	sq.m		406.15	479.26	
10 Sanitary fixtures					
a Rural squatting pan	number	1	350.00	413.00	413.00
b Girl's squatting urinal	number		300.00	354.00	0.00
11 Plumbing					
a GI pipe water supply line (internal) +3m external	m.m	4.5664	78.65	92.81	423.79
b Taps	number	3	250.00	295.00	885.00
c Waste water pipe for flushing	m.m	4.4076	31.05	36.64	161.49
12 Sewage					
a Sewage line from squatting pan to first IC + 3m	m.m	4.4806	111.60	131.69	590.04
b Waste drain line from urinal to first IC + 3m	m.m	3.5774	111.60	131.69	471.10
13 Roof work					
a Roof area (sloping, with overhangs and overlaps)	sq.m	10.2526	700.00	700.00	7176.82
14 Doors					
a D1	number		500.00	590.00	
b D2	number		500.00	590.00	
c D3	number	1	500.00	590.00	590.00
d D4	number	1	500.00	590.00	590.00
e D5	number		500.00	590.00	0.00
f Storage door shutter	number	1	500.00	590.00	590.00
15 Ventilators					
a V1	number		350.00	413.00	0.00
b V2	number	4	350.00	413.00	1652.00
c V3	number		350.00	413.00	
d V4	number		350.00	413.00	0.00
16 Incinerator					
a Metal / Masonry incinerator	number		1500.00	1500.00	0.00
17 Painting work					
a Internal white washing	sq.m	22.3389	35.40	41.77	933.14
b External wall painting	sq.m	21.8273	30.00	35.40	772.69
c Door and ventilator	sq.m	8.9205	58	68.44	610.52
18 Metal Work					
a Grab bars in toilets 40mm dia MS pipe	m.m		32.10	37.88	
b Rail in 40mm dia MS pipe in ramp	m.m	2.9285	32.10	37.88	110.93
c Vertical rail supports 25mm dia MS bars	m.m	4.075	32.10	37.88	154.35

Total Amount Rs. 41712
Total Area Sq.m 5.08
Cost per sqm 8211

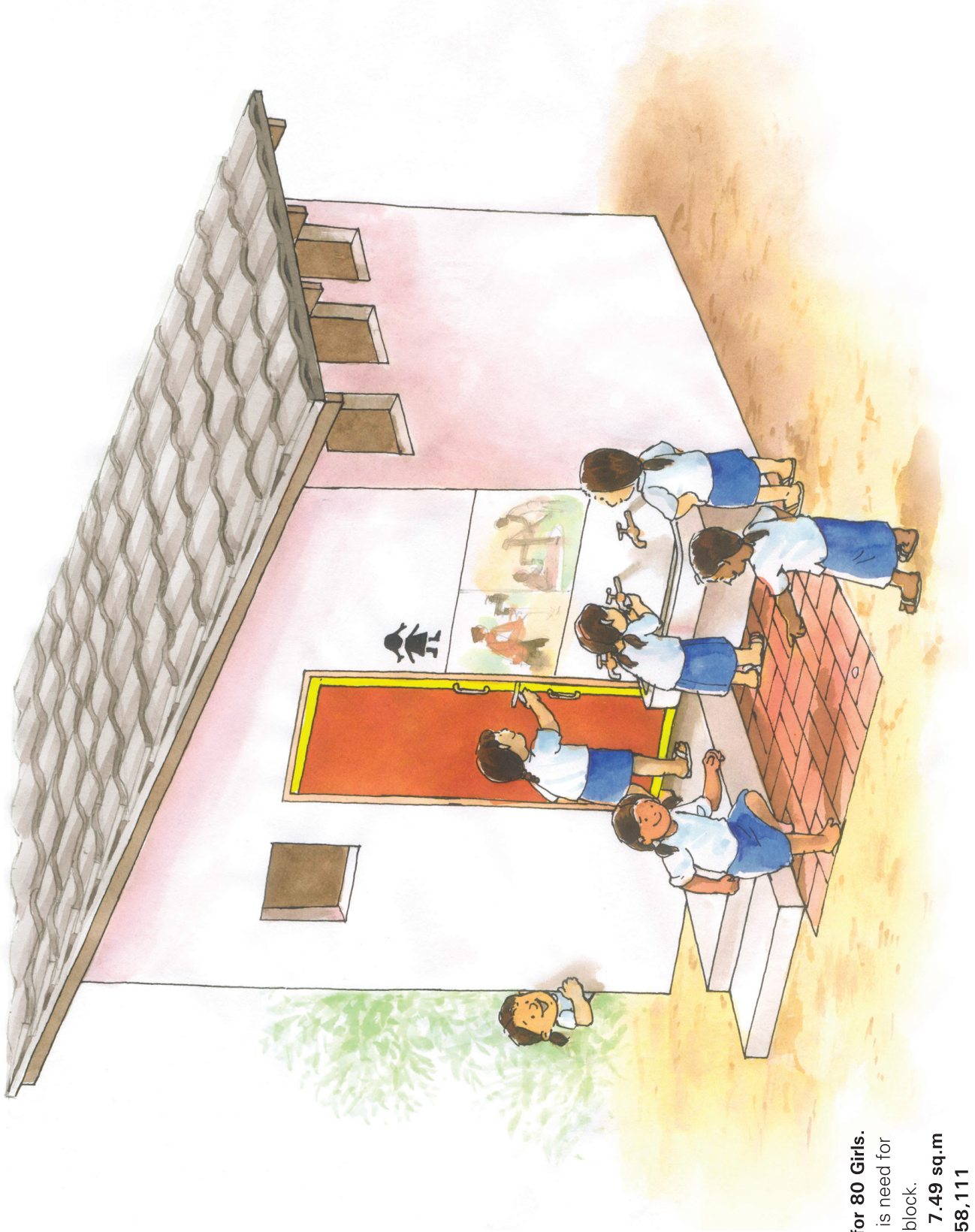

Basic Core Design for 80 Girls.
Suitable when there is need for separate girl's toilet block.
Total Built-up Area: 7.49 sq.m
Indicative cost* Rs 58,111

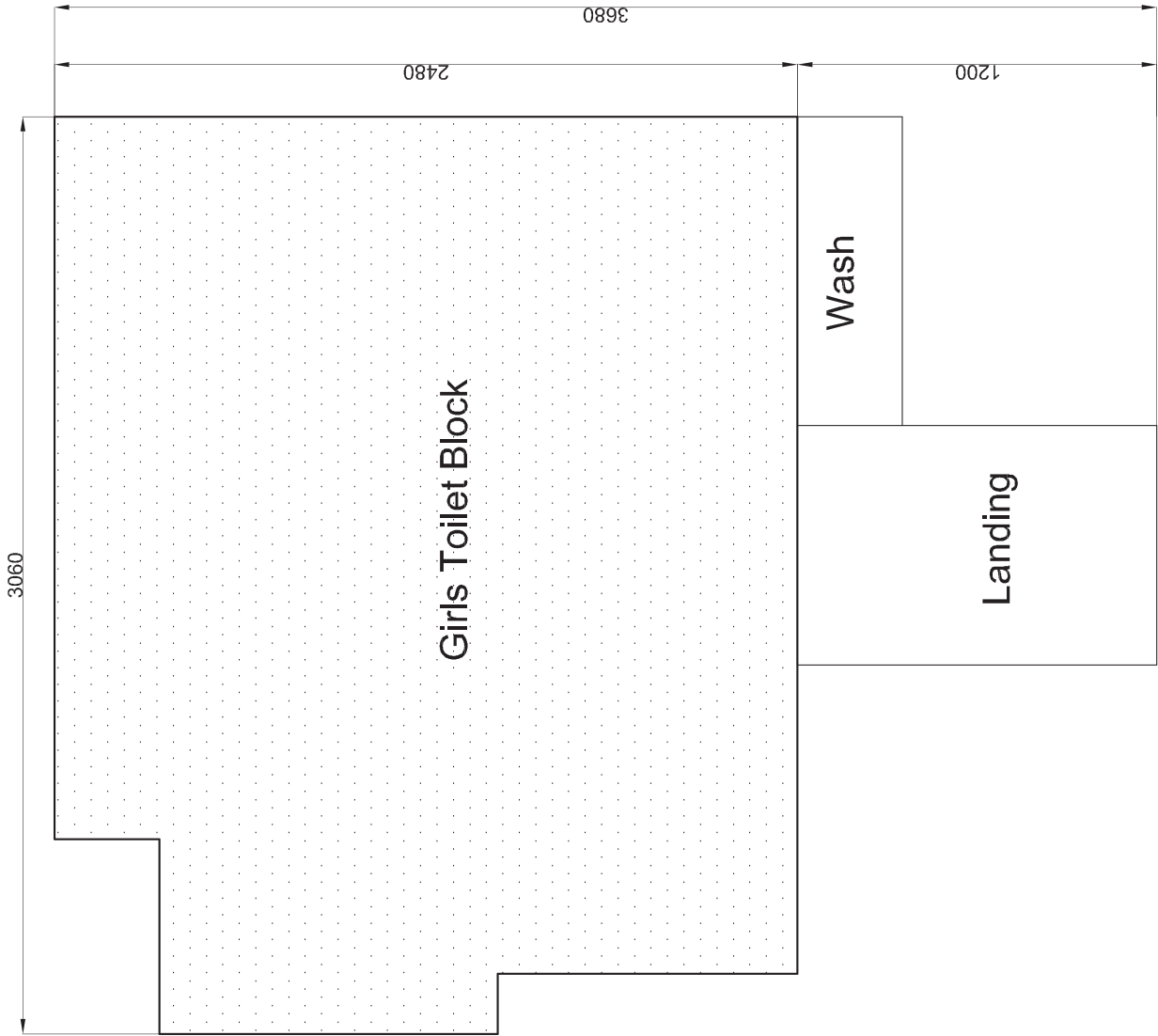

04

Proposed Toilet BCD 80G
Planning and Site Layout

Notes

- This design is valid for brick strength not below 35kg/sq.cm.
- Foundation design is only indicative & may need review based on local site conditions.
- For masonry water tank, the foundation shall be in 230mm brick up to the base of the tank.
- Monitor 1:4 for 115mm thick masonry. No reinforcement bars in alternate courses.
- This design is valid for earth quake zone I, II & III regions only
- No water supply or waste water carrying pipe shall be concealed in the masonry wall. It shall be exposed and fixed with clips and not chased in masonry walls.
- In case the masonry specification is changed from that given here, maintain the internal clear dimensions and the layout and provide suitable redesigned foundation.
- Sloping roof overhang and its anchorage design may need review in cyclone prone regions.
- No water supply or waste water carrying pipe that given here (e.g. flat roof in stone or RCC) provide suitable strengthening of masonry while maintaining all internal clearances in the layout design.
- Only one metallic / masonry incinerator to be put along the location indicative as ICN.
- Incinerator to be provided only with Girl's toilet and to have chute from inside.
- Location of leach pits, soak pits, waste drainage pipes & inspection chamber is indicated only. Actual location to be decided based on site conditions.
- Minimum distance of leaching pit from building foundation to be 125cm in different soil types.
- Design of leach pit shown is for 80 children with its volume sufficient for catering approximately one year in different soil types. For higher capacity or longer duration, design will need review.

Key to symbols:

- Pipe carrying waste water from wash area to flush urinals.
- Open / Covered drain for waste from Urinal / Squatting pan.
- Masonry wall.
- Roof line

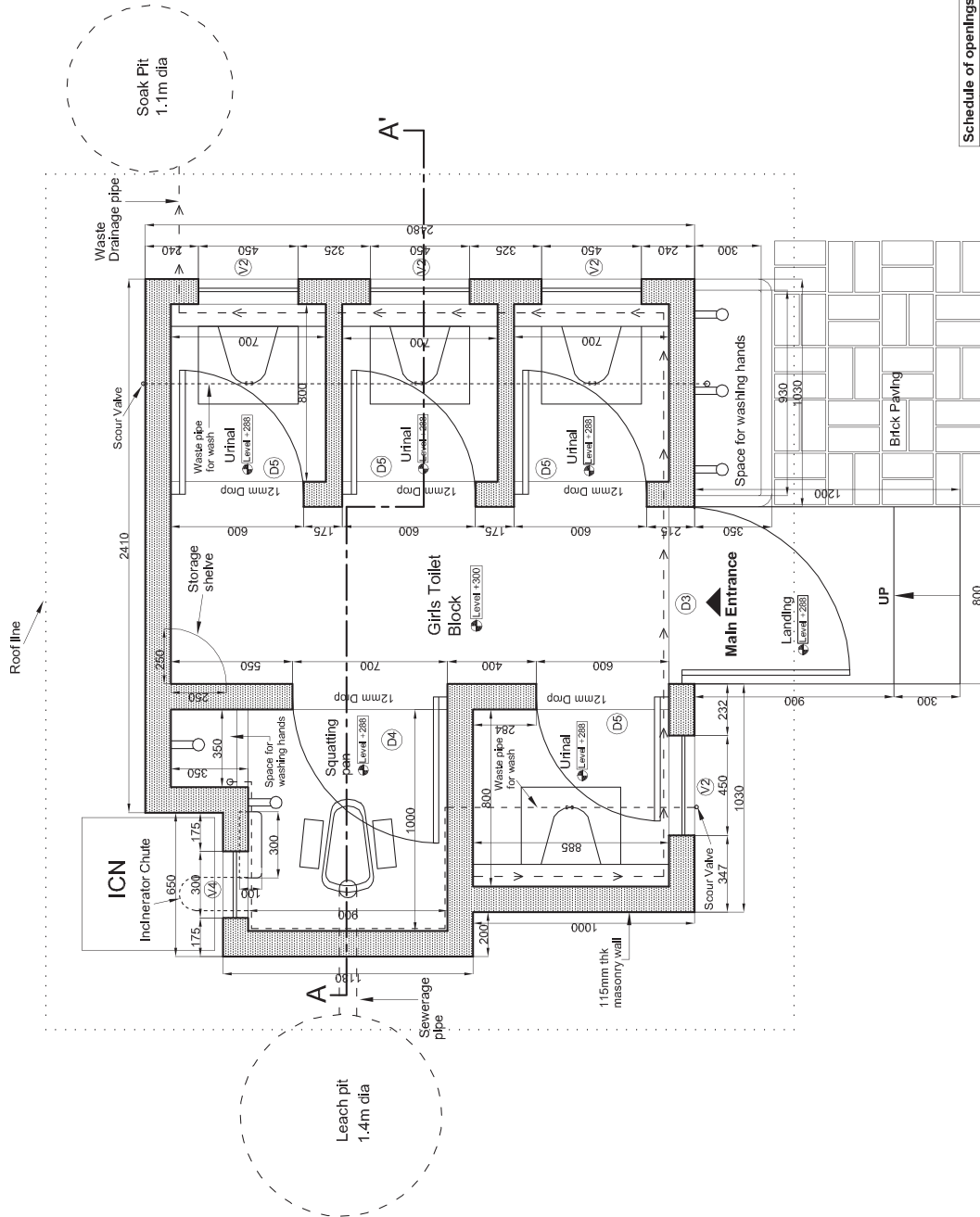

Schedule of openings		
Name	Size w X h	
D3	800x2100	
D4	700x2100	
D5	600x1500	
V2	450x450	
V4	300x450	

Area calculation	
Girls toilet block	7.16 sqm
Landing+Steps	1.08 sqm
Wash	0.33 sqm
Total Overall Area	8.57 sqm
Total Covered Area	7.49 sqm

Level ±00

Proposed Toilet BCD 80G

Plan

Scale: 2000/100

All dimensions are in mm

Suggested brief specifications:

- Civil work**
1. Pre-construction chemical termite treatment as per need.
 2. PCC 1:3:6 Cement: Coarse Sand; Coarse Aggregate in foundation.
 3. Foundation and Plinth in 1:4 cement mortar in brickwork.
 4. 75mm thick plinth band in 1:2:4 Reinforced Cement Concrete.
 5. Superstructure masonry in 1:4 cement mortar in 115 mm thick brick work.
 6. Pointing in 1:4 on exterior face.
 7. Plastering in 1:6 on interior face above dado level.
 8. All urinals and squatting pan area with ceramic tile floor and dado up to 750mm from finished floor.
 9. Use of waterproofing compound for plaster upto dado level and for fixing tile.
 10. All other flooring in cement concrete / stone tile as per availability. Slope in toilets & urinals floor is 1:50.
 11. 150mm thick lintel band in 1:2:4 Reinforced Cement Concrete.
 12. Built-in water tank with masonry walls and lining of waterproof cement plaster.
 13. Sloping roof in MCR / Country tile / Mangalore tile with metal / timber under-structure.
 14. Roof under-structure to be tied to masonry/tiltel band as per detail given.
 15. Door and ventilator frame in metal angle sections, painted with two coat of primer before installation.
 16. Door shutter in PVC/metal painted with two coats of primer and painted with enamel paint in light colour.
- Plumbing and Sanitary work**
17. All plumbing pipes in B class GI pipes with suitable elbow / tee / nipple / union / scour valves.
 18. All taps of best quality, locally available.
 19. All waste water carrying pipes in HDPE / PVC to flush urinals.
 20. All girls urinals squatting type in glazed ceramic type, white in colour.
 21. All squatting pan of rural pan type in glazed ceramic type, white in colour.
 22. All drainage and sewage pipes from Urinals / Squatting pan area in HDPE / PVC / CI / SW as per local availability.
 23. Each pit with 115mm thick honeycomb brickwork in 1:4 cement sand mortar.

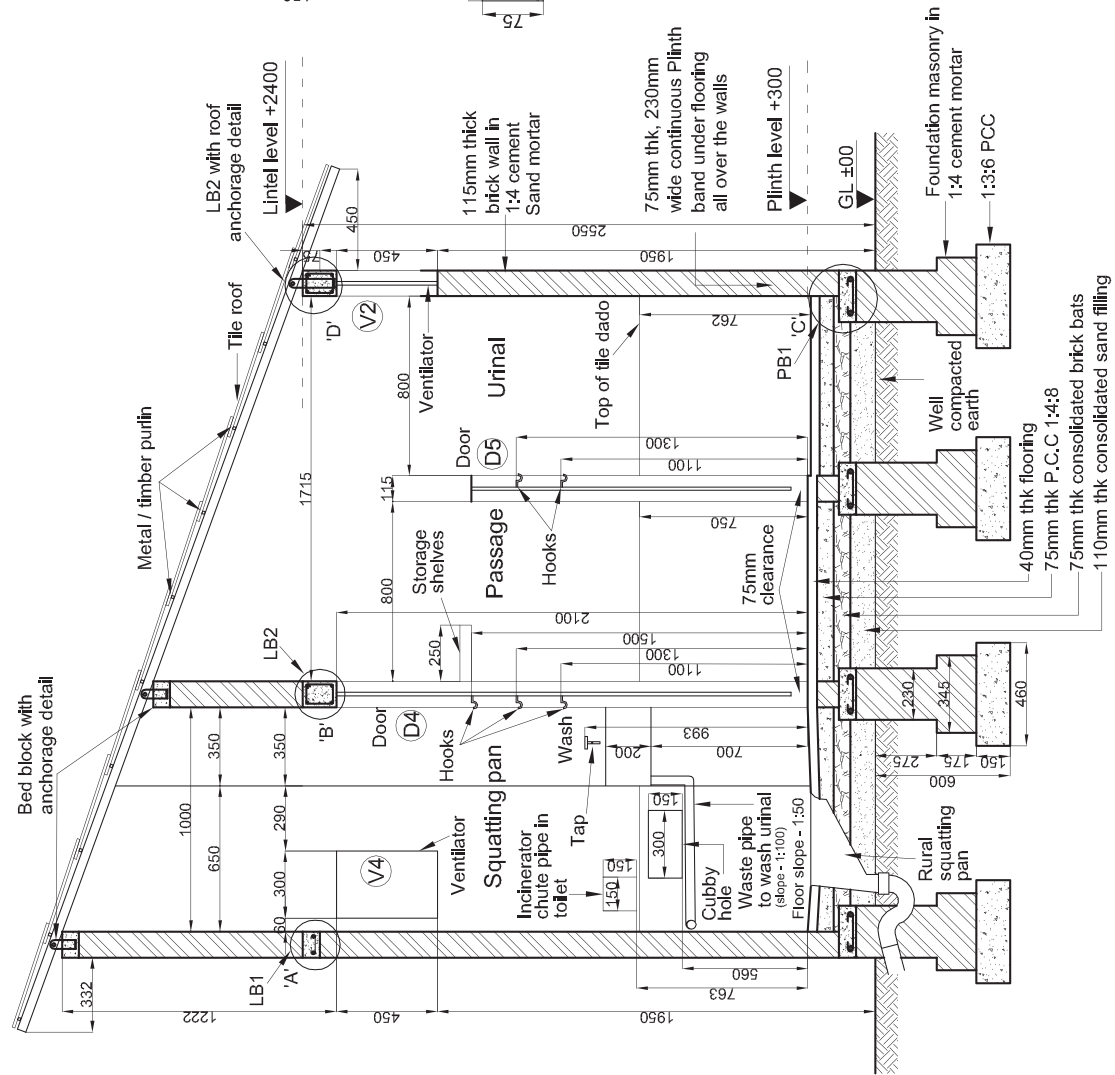
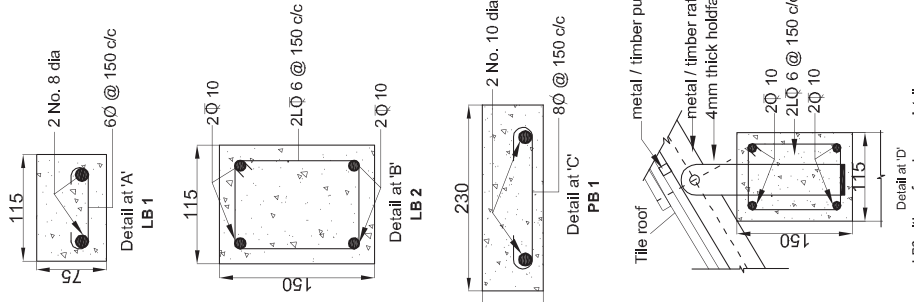

Section AA'

04

Proposed Toilet BCD 80G

Section and Details

Scale

All dimensions are in mm



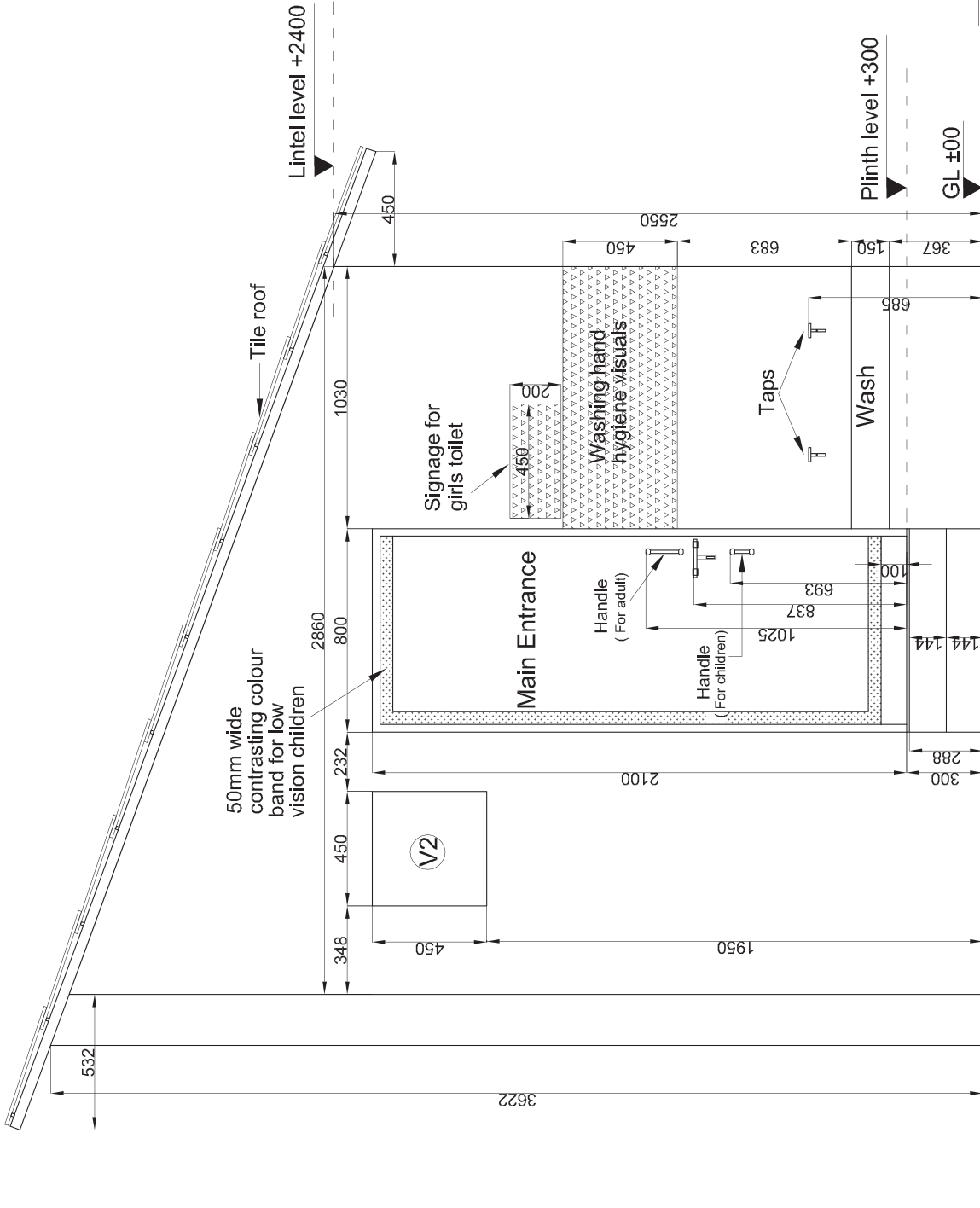

04

Schedule of openings		
Name	Size w x h	
D3	800x2100	
D4	700x2100	
D5	600x1500	
V2	450x450	
V4	300x450	

Proposed Toilet BCD 80G

Elevation

Scale: 1:50 or 1:100
 All dimensions are in mm

Front Elevation

Bill of quantities – 04 BCD 80G

ITEM	UNIT	Quantity	Rate	Indexed rate	Amount
9	Tile work				
a	Ceramic tile work in floor	3.4105	504.10	594.84	2028.69
b	Ceramic tile work in dado	10.3275	504.10	594.84	6143.19
c	Antiskid tiles in Ramp		406.15	479.26	
10	Sanitary fixtures				
a	Rural squatting pan	1	350.00	413.00	413.00
b	Girl's squatting urinal	4	300.00	354.00	1416.00
11	Plumbing				
a	GI pipe water supply line (internal) +3m external	8.99	78.65	92.81	834.33
b	Taps	5	250.00	295.00	1475.00
c	Waste water pipe for flushing	6.9616	31.05	36.64	255.07
12	Sewage				
a	Sewage line from squatting pan to first IC + 3m	3.568	111.60	131.69	469.86
b	Waste drain line from urinal to first IC + 3m	3.6226	111.60	131.69	477.05
13	Roof work				
a	Roof area (sloping, with overhangs and overlaps)	13.8208	700.00	700.00	9674.56
14	Doors				
a	D1	number	500.00	590.00	
b	D2	number	500.00	590.00	
c	D3	number	1	500.00	590.00
d	D4	number	1	500.00	590.00
e	D5	number	4	500.00	2360.00
f	Storage door shutter	number	500.00	590.00	0.00
15	Ventilators				
a	V1	number	350.00	413.00	0.00
b	V2	number	4	350.00	1652.00
c	V3	number	350.00	413.00	
d	V4	number	1	350.00	413.00
16	Incinerator				
a	Metal / Masonry incinerator	1	1500.00	1500.00	1500.00
17	Painting work				
a	Internal white washing	28.7433	35.40	41.77	1200.67
b	External wall painting	25.629	30.00	35.40	907.27
c	Door and ventilator	14.445	58	68.44	988.62
18	Metal Work				
a	Grab bars in toilets 40mm dia MS pipe	rr.m	32.10	37.88	
b	Rail in 40mm dia MS pipe in ramp	rr.m	32.10	37.88	
c	Vertical rail supports 25mm dia MS bars	rr.m	32.10	37.88	

Total Amount Rs. 58111
Total Area Sq.m 7.49
Cost per sqm 7759

ITEM	UNIT	Quantity	Rate	Indexed rate	Amount
1	Excavation				
a	Foundation	4.6249	30.00	35.4	163.72
b	Leach and soak pit	4.2076	30.00	35.4	148.95
c	Ramp work		30.00	35.4	
2	PCC				
a	1:3:6 PCC in foundation	1.1223	1678.00	1980.04	2222.17
b	1:4:8 PCC in flooring	0.5355	1503.60	1774.25	950.18
c	1:4:8 PCC in Ramp		1503.60	1774.25	
3	Back-filling				
a	Foundation	1.3500	25.55	30.15	40.70
b	Sand fill under floor	0.4139	95.60	112.81	46.69
c	Consolidated aggregate under floor	0.3998		0.00	0.00
d	Infill in soak pit	1.8997	25.55	30.15	57.27
e	Back fill in Ramp		25.55	30.15	
4	Brick work				
a	Brickwork in foundation and plinth	2.3259	1452.9	1714.42	3987.57
b	Brickwork in Ramp		1452.90	1714.42	
c	Honey comb brickwork in leach pit	6.0540	216.45	255.41	1546.26
d	75mm thk masonry partition in superstructure	2.7450	119.4	140.89	386.75
e	115mm thick masonry in superstructure	33.1233	199.00	234.82	7778.01
f	230mm thick masonry in superstructure		1690.45	1994.73	
g	Brick work in steps	0.2419	1690.45	1994.73	482.53
h	Dry brick work in paving	1.1631	80.85	95.40	110.96
5	RCC work				
a	1:2:4 RCC Plinth band	0.2798	5209.75	6147.51	1719.81
b	1:2:4 RCC Lintel band (all types)	0.2063	5209.75	6147.51	1268.23
c	1:2:4 PCC bed blocks for roof anchorage	0.0179	2136.35	2520.89	45.01
6	Slab (Stone / precast RCC)				
a	125mm thk Slab under water tank		570.79	673.53	
b	75mm thk Slab under hand wash areas (all)	0.5920	342.47	404.11	239.24
c	50mm thk Partition shelves in storage	0.3675	228.31	269.41	99.01
d	75mm thk Cover for water tank		342.47	404.11	
e	75mm thk Cover for leach pit	1.5386	342.47	404.11	621.77
7	Pointing and plastering				
a	1:4 pointing in exposed brick work	25.6290	29.75	35.11	899.71
b	1:6 cement sand plastering	28.7433	39.90	47.08	1353.29
c	1:6 cement sand with waterproof plastering	1.7363	32.73	38.62	67.06
8	Flooring				
a	Cement concrete flooring	2.8765	143.85	169.74	488.27

cu.m – Cubic meter, sq.m – Square meter, rr.m – Running meter

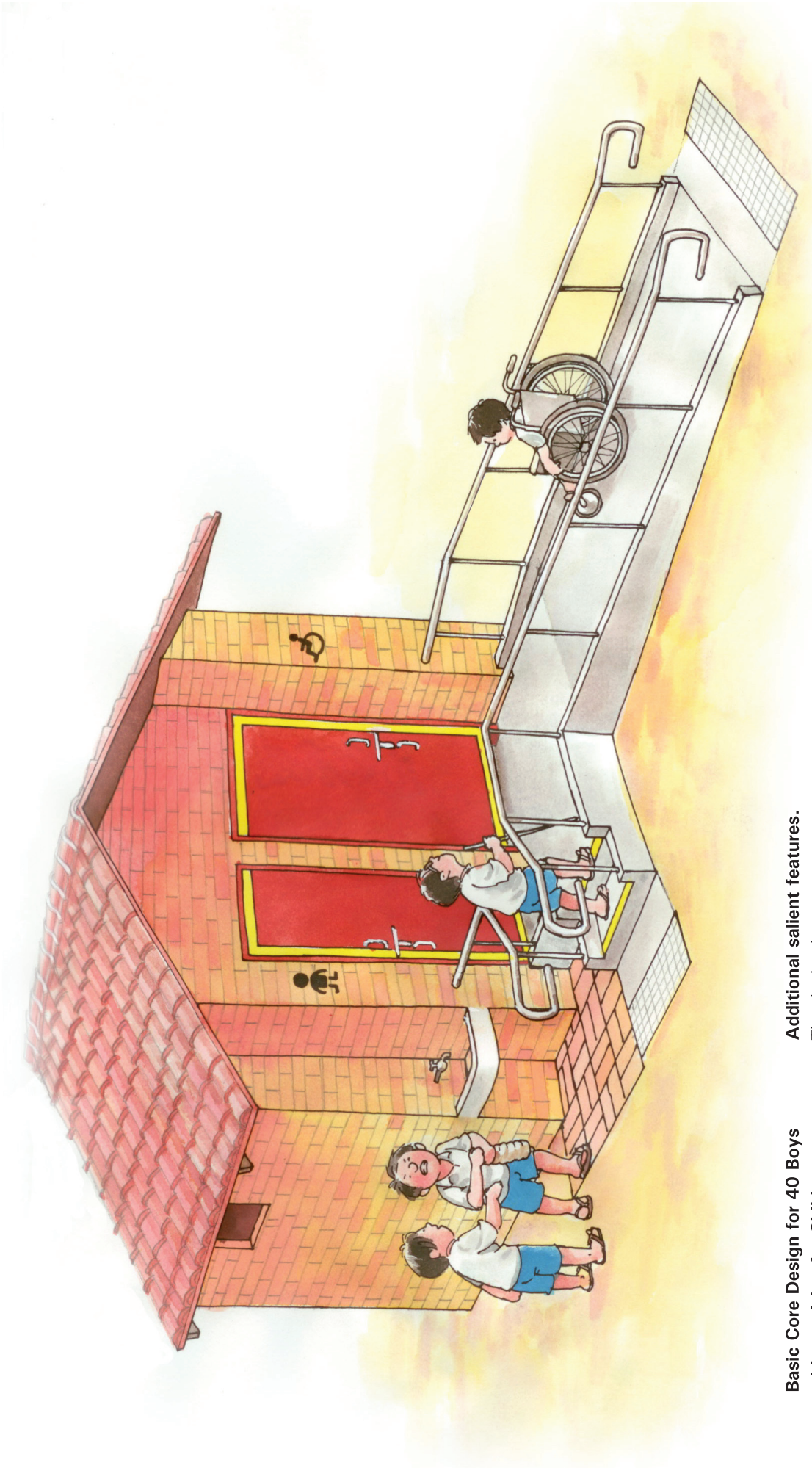

Basic Core Design for 40 Boys with provision for Children With Special Needs

Suitable when there is need of boy's toilet as well as CWSN toilet.

Total Built-up Area: 6.49 sq.m
Indicative cost* Rs 49,997

Additional salient features.

The design has:

1. Accessibility ramp and rails for CWSN.
2. One toilet for boys / CWSN with internal wash and provision of internal grab bars and rails.

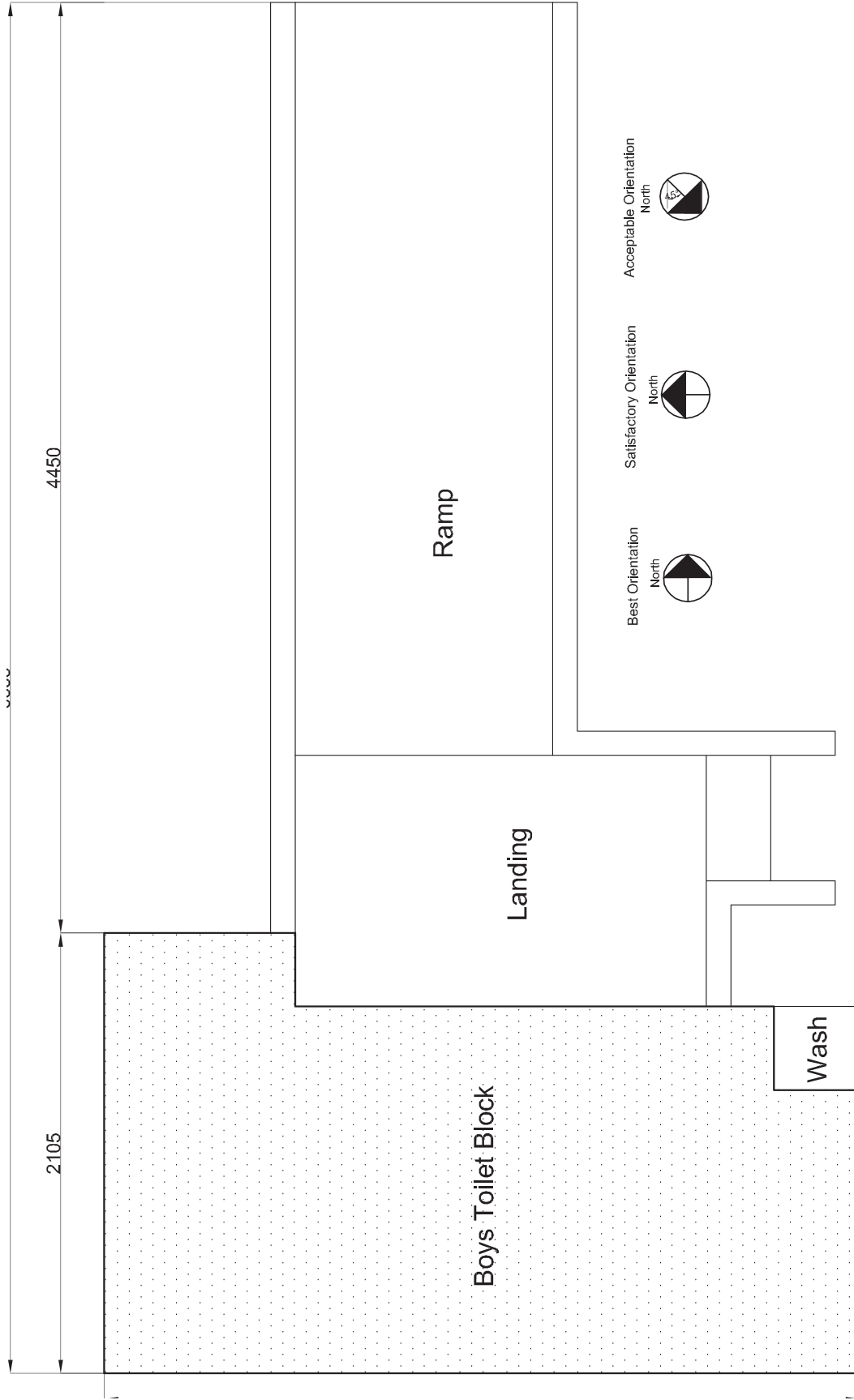

Plan – 05 BCD CWSN 40B

Notes

1. This design is valid for brick strength not below 35kg/sq.cm.
2. Foundation design is only indicative & may need review based on local site conditions.
3. For masonry water tank, the foundation shall be in 230mm brick up to the base of the tank.
4. Mortar 1:4 for 115mm thick masonry. No reinforcement bars in alternate courses.
5. This design is valid for earth quake zone I, II & III regions only
6. No water supply or waste water carrying pipe shall be concealed in the masonry wall. It shall be exposed and fixed with clips and not chased in masonry walls.
7. In case the masonry specification is changed from that given here, maintain the internal clear dimensions & the layout and provide suitable redesigned foundation.
8. Sloping roof overhang and its anchorage design may need review in cyclone prone regions.
9. In case roof specifications are changed from that given here (e.g. flat roof in stone or RCC) provide suitable strengthening of masonry while maintaining all internal clearances in the layout design.
10. Location of leach pits, soak pits, waste drainage pipes & inspection chamber is indicated only. Actual location to be decided based on site conditions.
11. Minimum distance of leaching pit from building foundation to be 125cm in different soil types.
12. Design of leach pit shown is for 40 children with its volume sufficient for catering approximately two years in different soil types. For higher capacity or longer duration, design will need review.

Key to symbols:

1. Pipe carrying waste water from wash area to flush urinals.
2. Open / Covered drain for waste from Urinal / Squatting pan.
3. Masonry wall.
4. Roof line.

05

Proposed Toilet BCD CWSN 40B

Plan

Scale



All dimensions are in mm

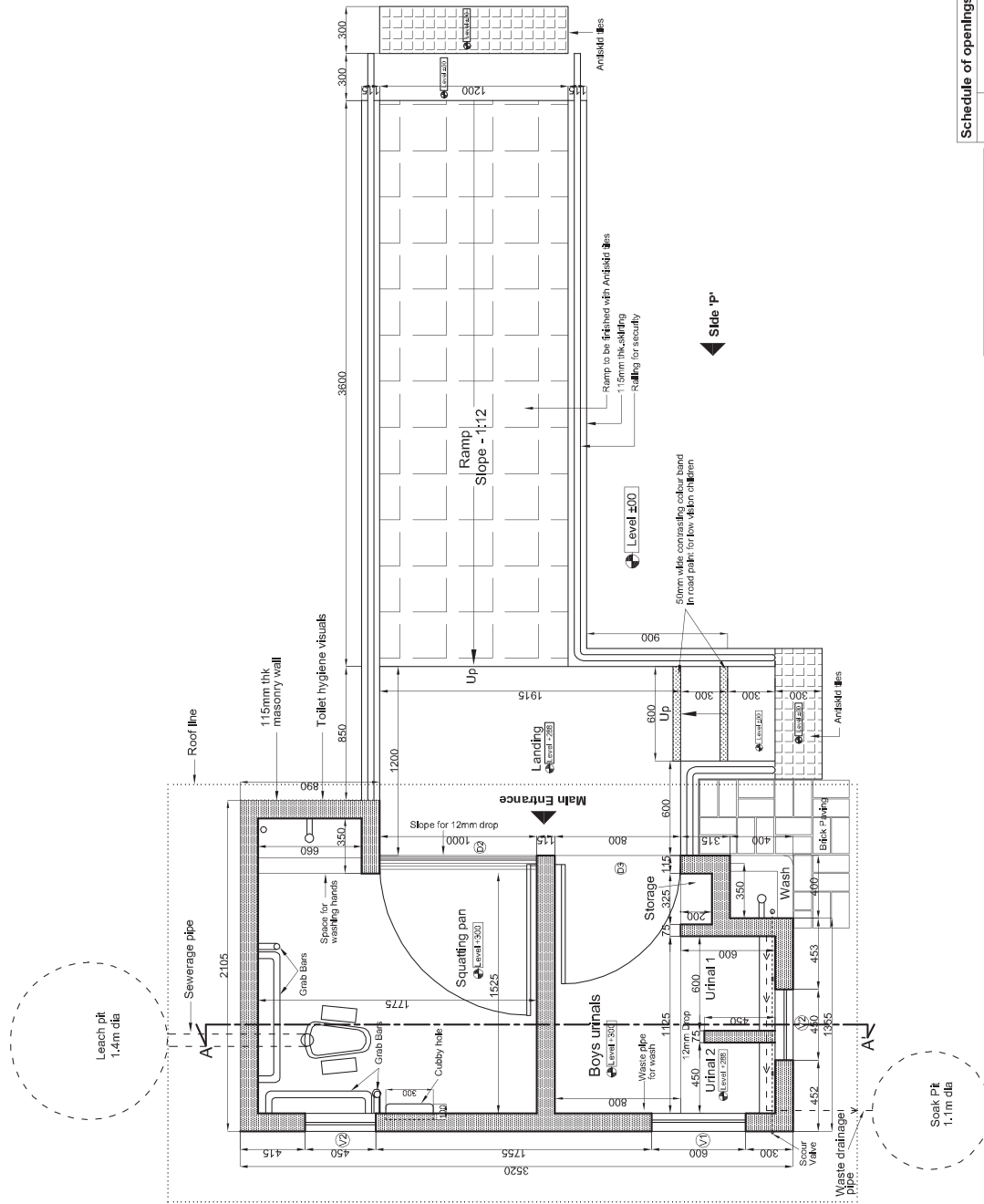

Schedule of openings

Name	Size w x h
D2	1000x2100
D3	800x2100
V1	600x450
V2	450x450

Area calculation	6.49 sqm
Boys Toilet block	6.49 sqm
Landing+Steps	2.47 sqm
Ramp	5.12 sqm
Total Overall Area	14.08 sqm
Total Covered Area	6.49 sqm

Section & Details – 05 BCD CWSN 40B

Suggested brief specifications:

- Civil work**
1. Pre-construction chemical termite treatment as per need.
 2. PCC 1:3:6 Cement: Coarse Sand: Coarse Aggregate in foundation.
 3. Foundation and Plinth in 1:4 cement mortar in brickwork.
 4. 75mm thick plinth band in 1:2:4 Reinforced Cement Concrete.
 5. Superstructure masonry in 1:4 cement mortar in 115 mm thick brick work.
 6. Plastering in 1:4 on exterior face.
 7. Plastering in 1:6 on interior face above dado level.
 8. All urinals and squatting pan area with ceramic tile floor and dado up to 750mm from finished floor.
 9. Use of waterproofing compound for plaster upto dado level and for fixing tile.
 10. All other flooring in cement concrete / stone tile as per availability. Slope in toilets & urinals floors is 1:50.
 11. 150mm thick Lintel band in 1:2:4 Reinforced Cement Concrete.
 12. Built-in water tank with masonry walls and lining of waterproof cement plaster.
 13. Sloping roof in MCR / Country tile / Mangalore tile with metal / timber under-structure.
 14. Roof under-structure to be tied to masonry/Intel band as per detail given.
 15. Door and ventilator frame in metal angle sections, painted with two coats of primer before installation.
 16. Door shutter in PVC/metal painted with two coats of primer and painted with enamel paint in light colour.

Plumbing and Sanitary work

17. All plumbing pipes in B class GI pipes with suitable elbow / tee / nipple / union / scour valves.
18. All taps of best quality, locally available.
19. All waste water carrying pipes in HDPE / PVC to flush urinals.
20. All girds urinals squatting type in glazed ceramic type, white in colour.
21. All squatting pan of rural pan type in glazed ceramic type, white in colour.
22. All drainage and sewage pipes from Urinals / Squatting pan area in HDPE / PVC / CI / SW as per local availability.
23. Leach pit with 115mm thick honeycomb brickwork in 1:4 cement sand mortar.

Schedule of openings	
Name	Size w x h
D2	1000x2100
D3	800x2100
V1	600x450
V2	450x450

05

Proposed Toilet BCD CWSN 40B
Section and Details

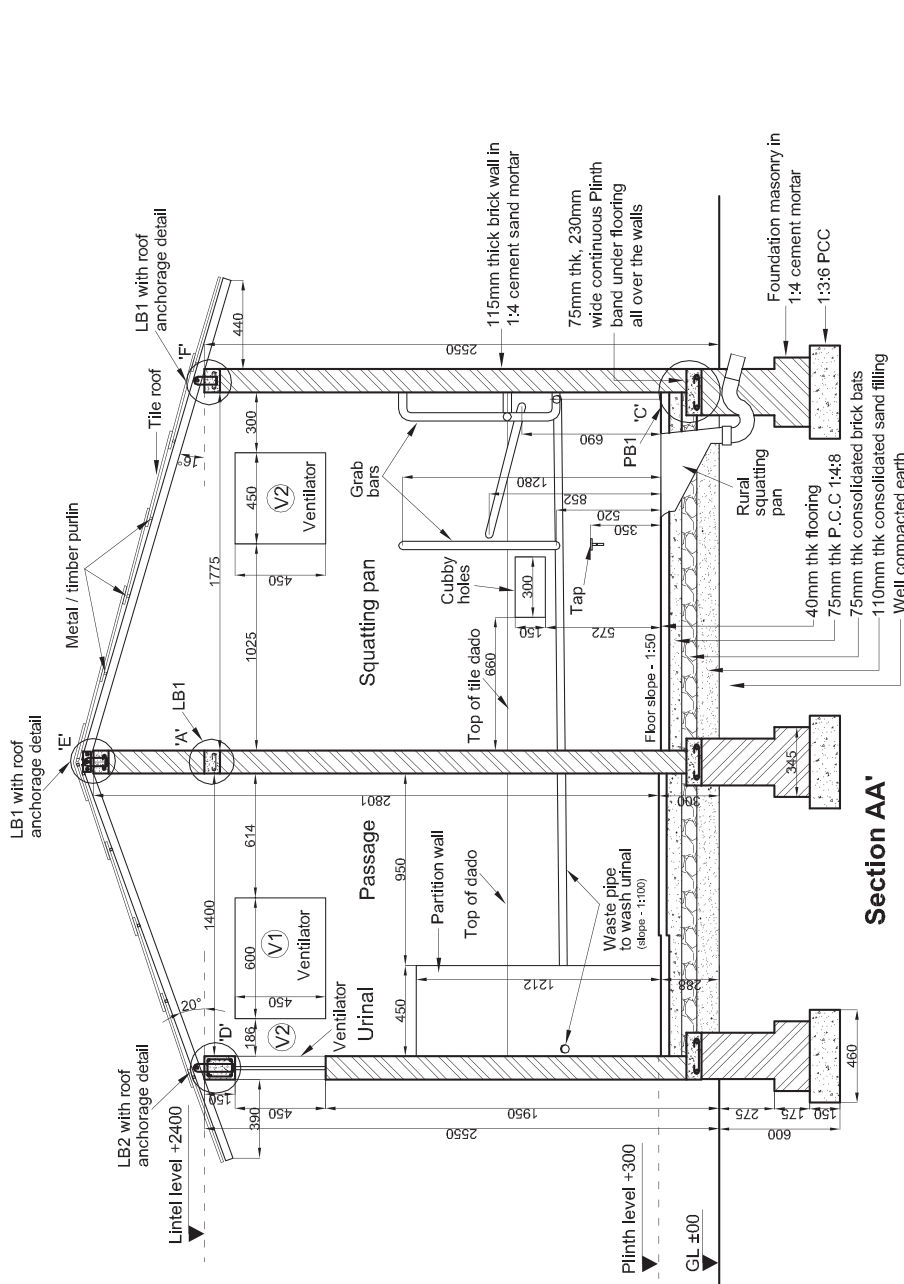
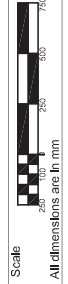

Section AA

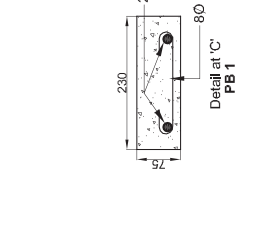
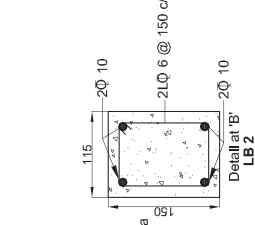
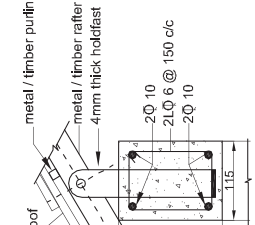
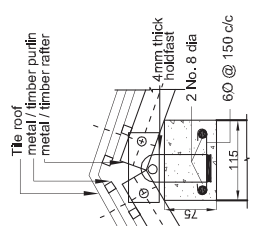
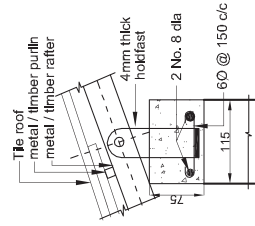

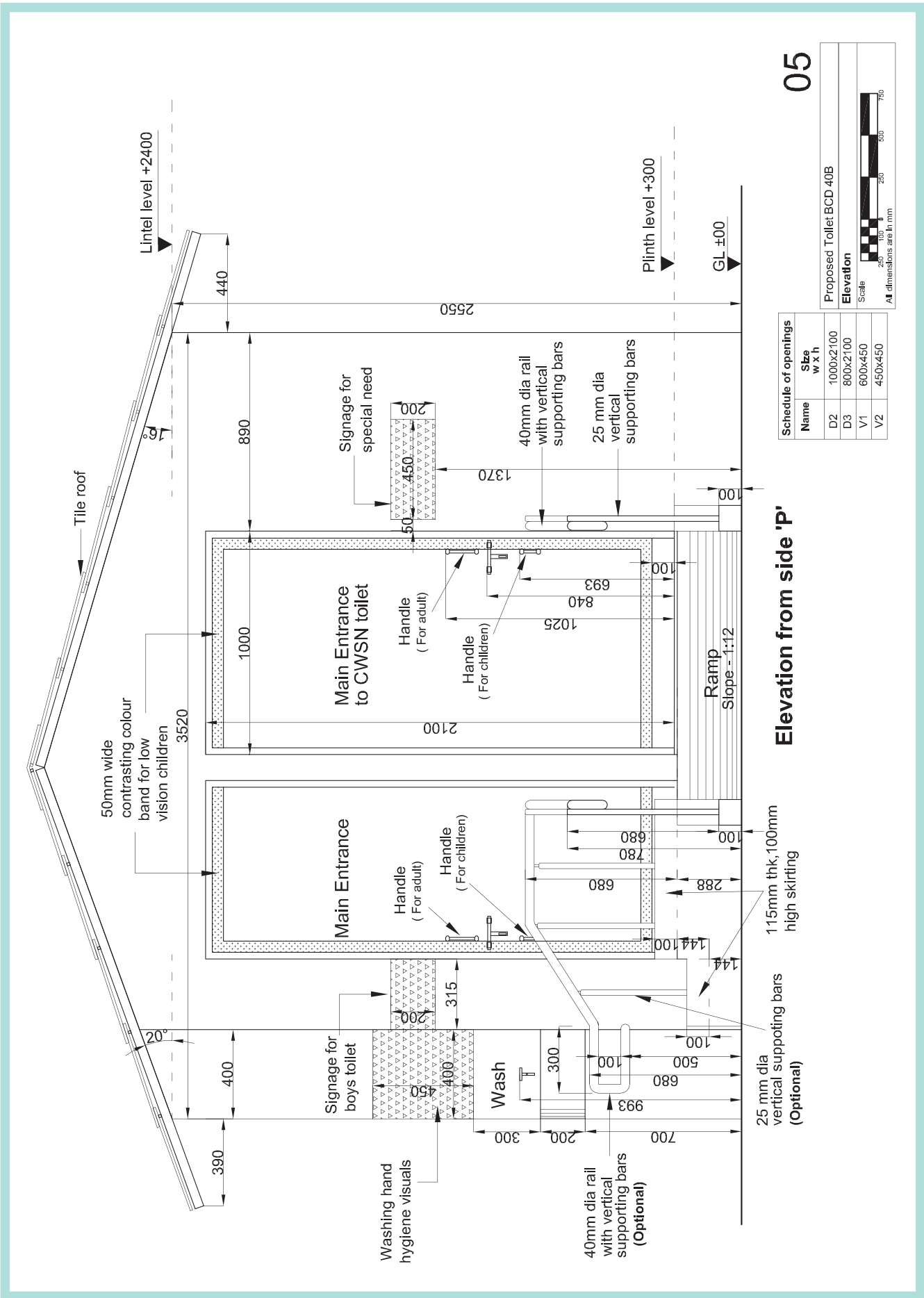

Schedule of openings

Name	Size W X H
D2	1000x2100
D3	800x2100
V1	600x450
V2	450x450

Proposed Toilet BCD 40B

Elevation

Scale: 1:50

All dimensions are in mm

Elevation from side 'P'

05

Bill of quantities – 05 BCD CWSN 40B

ITEM	UNIT	Quantity	Rate	Indexed rate	Amount
9	Tile work				
a	Ceramic tile work in floor	sq.m	3.694	504.10	594.84
b	Ceramic tile work in dado	sq.m	7.23	504.10	594.84
c	Antiskid tiles in Ramp	sq.m	4.9446	406.15	479.26
10	Sanitary fixtures				
a	Rural squatting pan	number	1	350.00	413.00
b	Girl's squatting urinal	number	300.00	354.00	0.00
11	Plumbing				
a	GI pipe water supply line (internal) +3m external	rn.m	9.423	78.65	92.81
b	Taps	number	3	250.00	295.00
c	Waste water pipe for flushing	rn.m	1.397	31.05	36.64
12	Sewage				
a	Sewage line from squatting pan to first IC + 3m	rn.m	3.8762	111.60	131.69
b	Waste drain line from urinal to first IC + 3m	rn.m	3.6347	111.60	131.69
13	Roof work				
a	Roof area (sloping, with overhangs and overlaps)	sq.m	12.1498	700.00	700.00
14	Doors				
a	D1	number	1	500.00	590.00
b	D2	number	1	500.00	590.00
c	D3	number	1	500.00	590.00
d	D4	number	1	500.00	590.00
e	D5	number	1	500.00	590.00
f	Storage door shutter	number	1	500.00	590.00
15	Ventilators				
a	V1	number	1	350.00	413.00
b	V2	number	2	350.00	413.00
c	V3	number	1	350.00	413.00
d	V4	number	1	350.00	413.00
16	Incinerator				
a	Metal / Masonry incinerator	number	1	1500.00	1500.00
17	Painting work				
a	Internal white washing	sq.m	23.0058	35.40	41.77
b	External wall painting	sq.m	24.2325	30.00	35.40
c	Door and ventilator	sq.m	8.235	58	68.44
18	Metal Work				
a	Grab bars in toilets 40mm dia MS pipe	rn.m	4.1448	32.10	37.88
b	Rail in 40mm dia MS pipe in ramp	rn.m	20.5861	32.10	37.88
c	Vertical rail supports 25mm dia MS bars	rn.m	10.595	32.10	37.88

Total Amount Rs. 49997
Total Area Sq.m 6.49
Cost per sqm 7704

ITEM	UNIT	Quantity	Rate	Indexed rate	Amount
1	Excavation				
a	Foundation	cu.m	3.4304	30.00	121.44
b	Leach and soak pit	cu.m	4.2076	30.00	148.95
c	Ramp work	cu.m	1.5180	30.00	53.74
2	PCC				
a	1:3:6 PCC in foundation	cu.m	0.8576	1678.00	1698.08
b	1:4:8 PCC in flooring	cu.m	0.3742	1503.60	663.99
c	1:4:8 PCC in Ramp	cu.m	1.0916	1503.60	1936.77
3	Back-filling				
a	Foundation	cu.m	1.0316	25.55	31.10
b	Sand fill under floor	cu.m	0.7103	95.60	80.13
c	Consolidated aggregate under floor	cu.m	0.8326	0.00	0.00
d	Infill in soak pit	cu.m	1.8997	25.55	57.27
e	Back fill in Ramp	cu.m	0.0591	25.55	1.78
4	Brick work				
a	Brickwork in foundation and plinth	cu.m	1.7773	1452.9	3047.12
b	Brickwork in Ramp	cu.m	0.8088	1452.90	1386.62
c	Honey comb brickwork in leach pit	sq.m	6.0540	216.45	1546.26
d	75mm thk masonry partition in superstructure	sq.m	1.1475	119.4	161.67
e	115mm thick masonry in superstructure	sq.m	27.5808	199.00	6476.52
f	230mm thick masonry in superstructure	cu.m	1690.45	1994.73	1994.73
g	Brick work in steps	cu.m	0.0270	1690.45	53.86
h	Dry brick work in paving	sq.m	0.6293	80.85	60.04
5	RCC work				
a	1:2:4 RCC Plinth band	cu.m	0.2138	5209.75	1314.21
b	1:2:4 RCC Lintel band (all types)	cu.m	0.1421	5209.75	873.56
c	1:2:4 PCC bed blocks for roof anchorage	cu.m	0.0159	2136.35	40.01
6	Slab (Stone / precast RCC)				
a	125mm thk Slab under water tank	sq.m	570.79	673.53	673.53
b	75mm thk Slab under hand wash areas (all)	sq.m	0.4840	342.47	404.11
c	50mm thk Partition shelves in storage	sq.m	0.3188	228.31	269.41
d	75mm thk Cover for water tank	sq.m	342.47	404.11	404.11
e	75mm thk Cover for leach pit	sq.m	1.5386	342.47	621.77
7	Pointing and plastering				
a	1:4 pointing in exposed brick work	sq.m	24.2325	29.75	35.11
b	1:6 cement sand plastering	sq.m	23.0058	39.90	47.08
c	1:6 cement sand with waterproof plastering	sq.m	1.8000	32.73	69.52
8	Flooring				
a	Cement concrete flooring	sq.m	3.6100	143.85	612.77

cu.m – Cubic meter, sq.m – Square meter, rn.m – Running meter

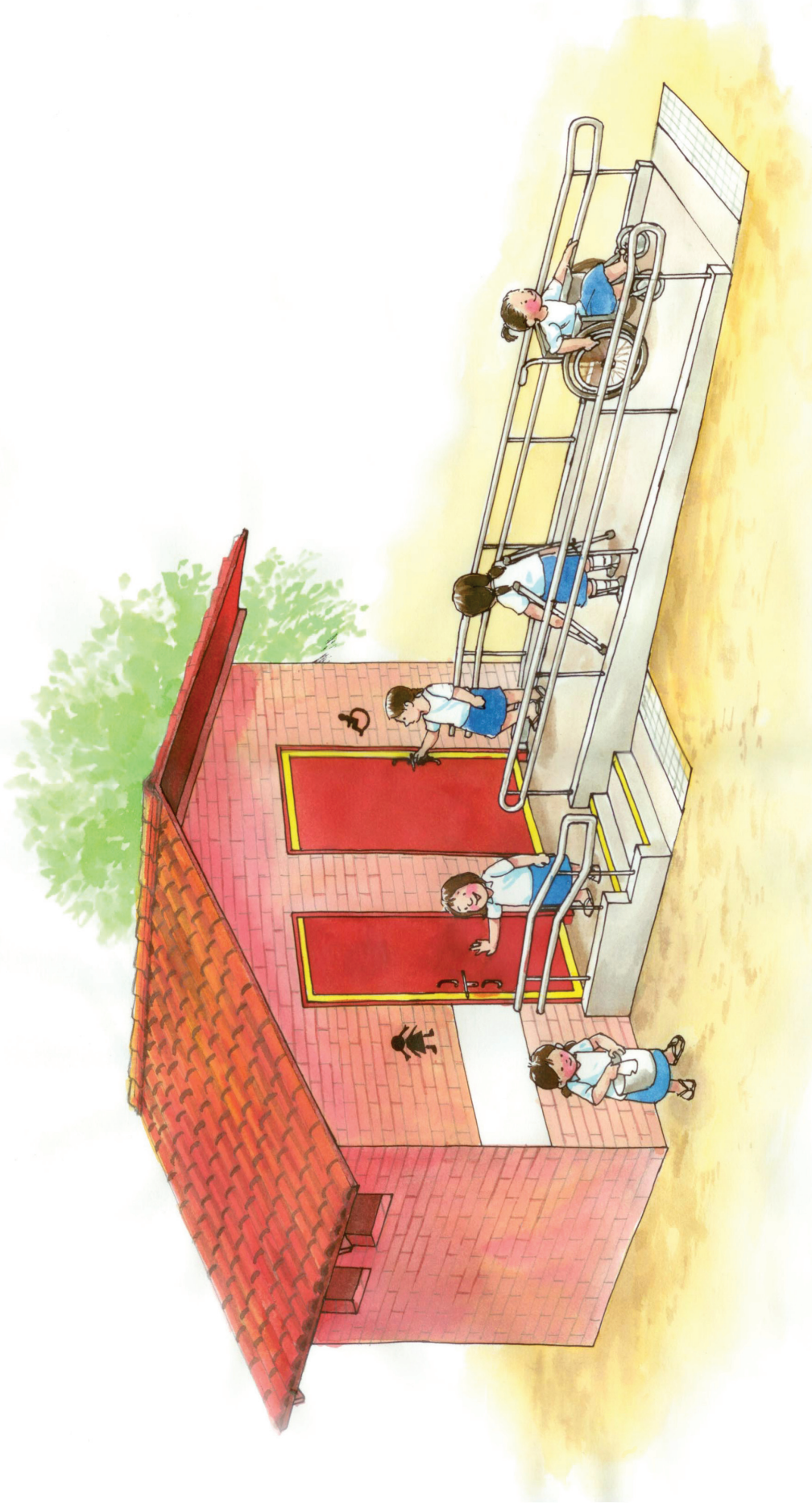

Basic Core Design for 40 Girls with provision for Children With Special Needs

Suitable when there is need of Girl's toilet as well as CWSN toilet.

Total Built-up Area: 7.35 sq.m

Indicative cost Rs 59,311

Additional salient features:

The design has:

1. Accessibility ramp and rails for CWSN.
2. One toilet for girls / CWSN with internal wash and provision of internal grab bars and rails.

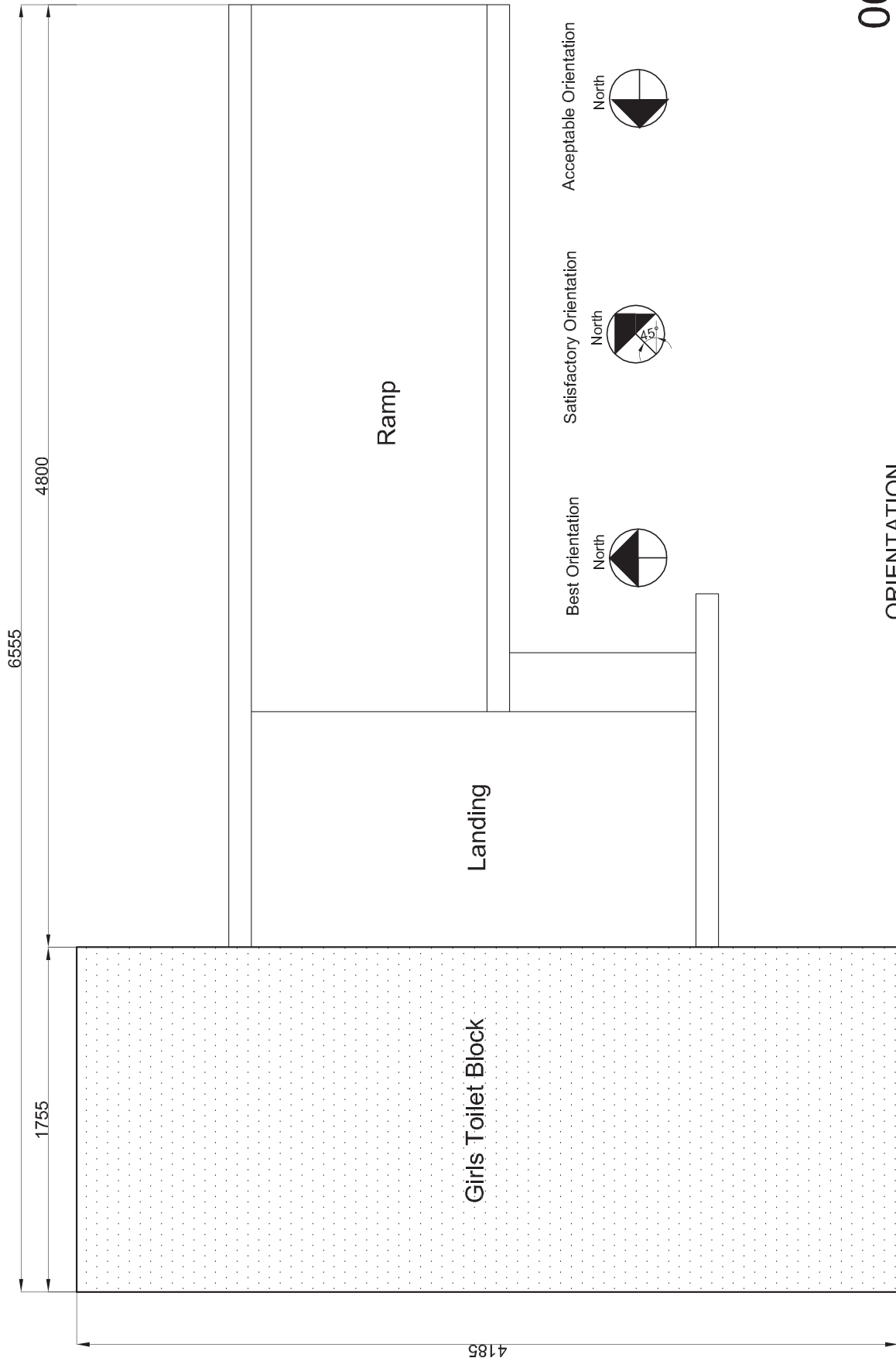

ORIENTATION

06

Proposed Toilet BCD CWSN 40G
Planning and Site Layout

Notes

1. This design is valid for brick strength not below 3.5kg/sq.cm.
2. Foundation design is only indicative & may need review based on local site conditions.
3. For masonry water tank, the foundation shall be in 230mm brick up to the base of the tank.
4. Mortar 1:4 for 115mm thick masonry. No reinforcement bars in alternate courses.
5. This design is valid for earth quake zone I, II & III regions only
6. No water supply or waste water carrying pipe shall be concealed in the masonry wall. It shall be exposed and fixed with clips and not chased in masonry walls.
7. In case the masonry specification is changed from that given here, maintain the internal clear dimensions and the layout and provide suitable redesigned foundation.
8. Sloping roof overhang and its anchorage design may need review in cyclone prone regions.
9. In case roof specifications are changed from that given here (e.g. flat roof in stone or RCC) provide suitable strengthening of masonry while maintaining all internal clearances in the layout design.
10. Only one metallic / masonry incinerator to be put along the location indicative as ICN.
11. Incinerator to be provided only with Girl's toilet and to have chute from inside.
12. Location of leach pits, soak pits, waste drainage pipes & inspection chamber is indicated only. Actual location to be decided based on site conditions.
13. Minimum distance of leaching pit from building foundation to be 125cm in different soil types.
14. Design of leach pit shown is for 40 children with its volume sufficient for catering approximately two years in different soil types. For higher capacity or longer duration, design will need review.

Key to symbols:

1. - - - - - Pipe carrying waste water from wash area to flush urinals.
2. - - - - - Open / Covered drain for waste from Urinal / Squatting pan.
3. [Symbol] Masonry wall.
4. [Symbol] Roof line

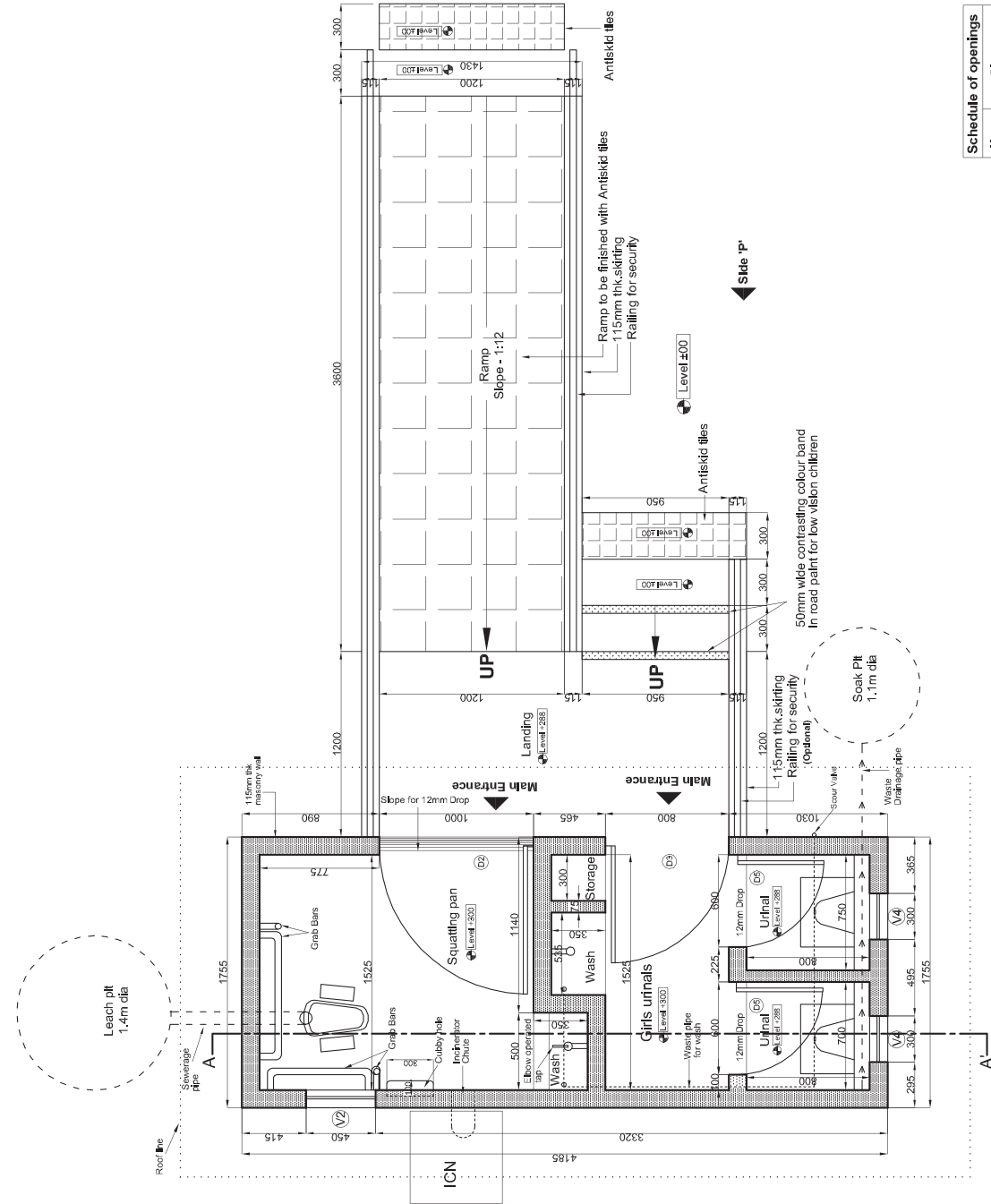

Schedule of openings

Name	Size w x h
D2	1000x2100
D3	800x2100
D5	600x1500
V2	450x450
V4	300x450

Area calculation	Size
Girls Toilet block	7.35 sqm
Landing+Steps	3.63 sqm
Ramp	5.15 sqm
Total Overall Area	16.13 sqm
Total Covered Area	7.35 sqm

06

Proposed Toilet BCD CWSN 40G

Plan

Scale

All dimensions are in mm



Section & Details – 06 BCD CWSN 40G

Suggested brief specifications:

- Civil work**
1. Pre-construction chemical termite treatment as per need.
 2. PCC 1:3:6 Cement: Coarse Sand: Coarse Aggregate in foundation.
 3. Foundation and Plinth in 1:4 cement mortar in brickwork.
 4. 7.5mm thick plinth band in 1:2:4 Reinforced Cement Concrete.
 5. Superstructure masonry in 1:4 cement mortar in 115 mm thick brick work.
 6. Pointing in 1:4 on exterior face.
 7. Plastering in 1:6 on interior face above dado level.
 8. All urninals and squatting pan area with ceramic tile floor and dado up to 750mm from finished floor.
 9. Use of waterproofing compound for plaster upto dado level and for fixing tile.
 10. All other flooring in cement concrete / stone tile as per availability. Slope in toilets & urninals floor is 1:50.
 11. 150mm thick Lintel band in 1:2:4 Reinforced Cement Concrete.
 12. Built-in water tank with masonry walls and lining of waterproof cement plaster.
 13. Sloping roof in MCR / Country tile / Mangalore tile with metal / timber under-structure.
 14. Roof under-structure to be tied to masonry/lintel band as per detail given.
 15. Door and ventilator frame in metal angle sections, painted with two coats of primer before installation.
 16. Door shutter in PVC/metal painted with two coats of primer and painted with enamel paint in light colour.
- Plumbing and Sanitary work**
17. All plumbing pipes in B class GI pipes with suitable elbow / tee / nipple / union / scour valves.
 18. All taps of best quality, locally available.
 19. All waste water carrying pipes in HDPE / PVC to flush urninals.
 20. All gis urninals squatting type in glazed ceramic type, white in colour.
 21. All squatting pan of rural pan type in glazed ceramic type, white in colour
 22. All drainage and sewage pipes from Urinals / Squatting pan area in HDPE / PVC / CI / SW as per local availability.
 23. Leach pit with 115mm thick honeycomb brickwork in 1:4 cement sand mortar

Name	Size W x H
D2	1000x2100
D3	800x2100
D5	600x1900
V2	450x450
V4	300x450

06

Proposed Toilet BCD CWSN 40G

Section and Details

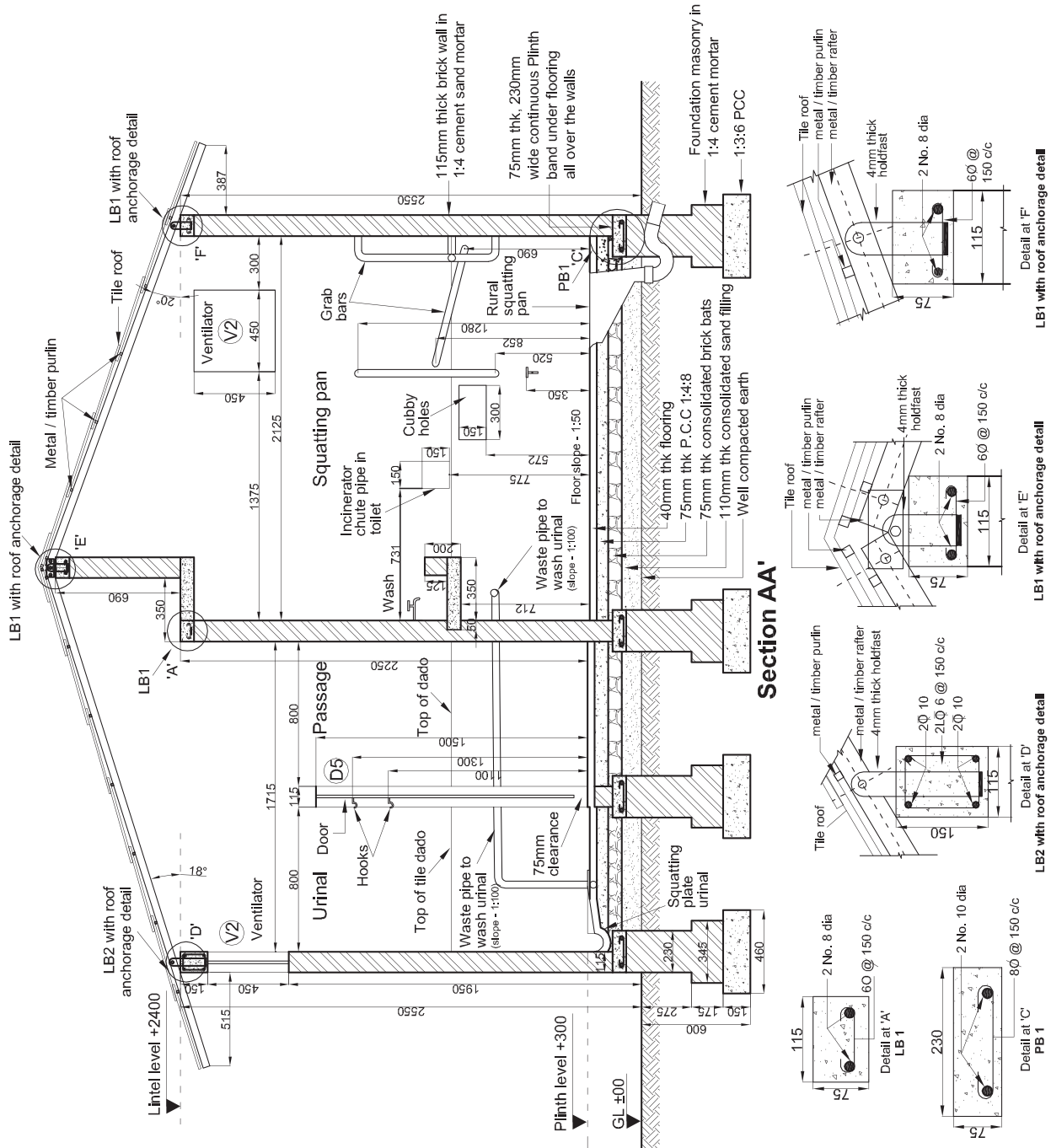

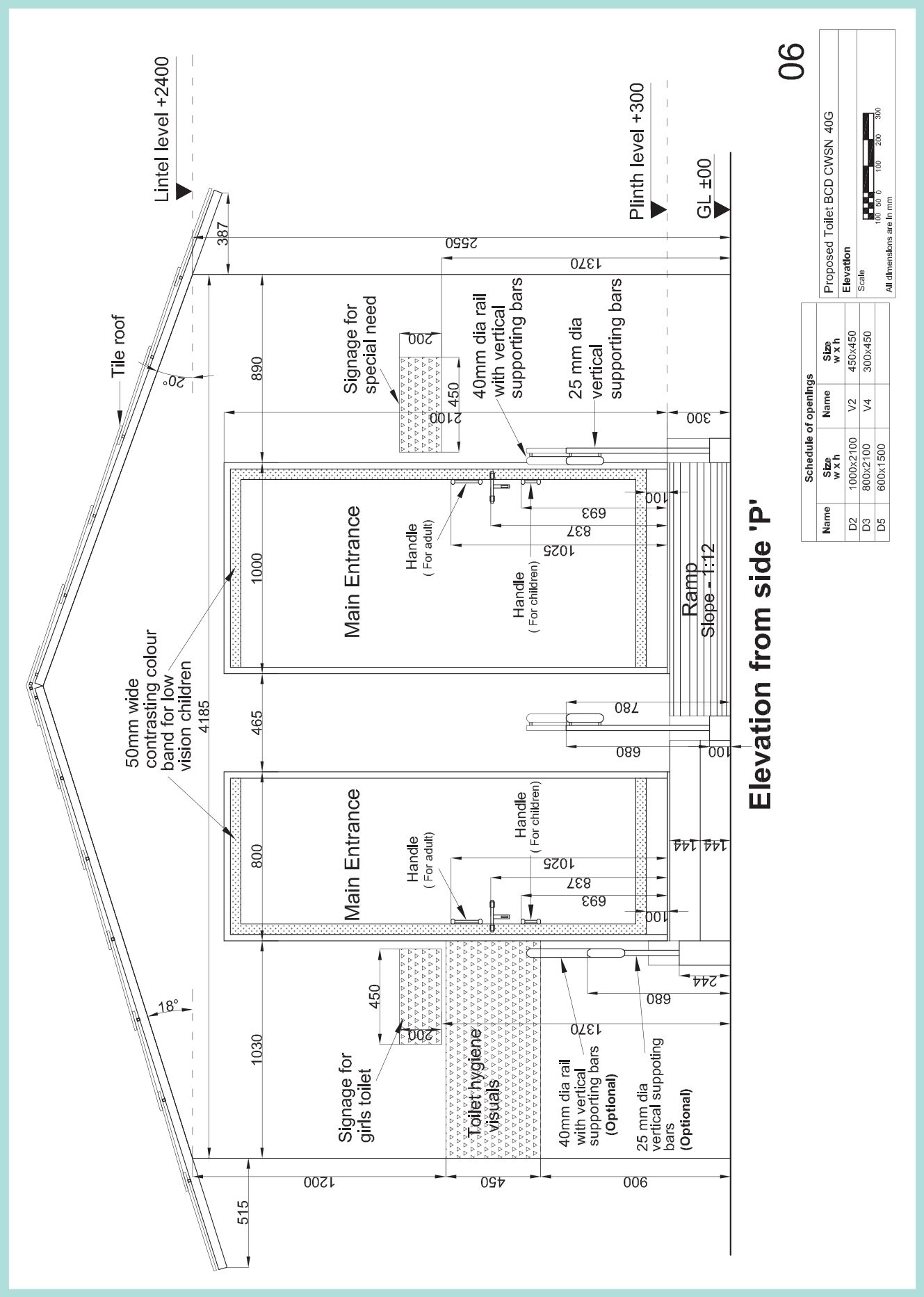

Elevation from side 'P'

06

Schedule of openings	
Name	Size W x H
D2	1000x2100
D3	800x2100
D5	600x1500

Proposed Toilet BCD CWSN 40G	
Elevation	Scale
	1:100 1:50 1:200 1:300

All dimensions are in mm

Bill of quantities – 06 BCD CWSN 40G

ITEM	UNIT	Quantity	Rate	Indexed rate	Amount
1 Excavation					
a Foundation	cu.m	4.1538	30.00	35.4	147.04
b Leach and soak pit	cu.m	4.2076	30.00	35.4	148.95
c Ramp work	cu.m	1.5480	30.00	35.4	54.80
2 PCC					
a 1:3:6 PCC in foundation	cu.m	1.0385	1678.00	1980.04	2056.17
b 1:4:8 PCC in flooring	cu.m	0.4230	1503.60	1774.25	750.56
c 1:4:8 PCC in Ramp	cu.m	1.1939	1503.60	1774.25	2118.27
3 Back-filling					
a Foundation	cu.m	1.2492	25.55	30.15	37.66
b Sand fill under floor	cu.m	0.7193	95.60	112.81	81.15
c Consolidated aggregate under floor	cu.m	0.9230		0.00	0.00
d Infill in soak pit	cu.m	1.8997	25.55	30.15	57.27
e Back fill in Ramp	cu.m	0.0591	25.55	30.15	1.78
4 Brick work					
a Brickwork in foundation and plinth	cu.m	2.1522	1452.9	1714.42	3689.69
b Brickwork in Ramp	cu.m	0.8797	1452.90	1714.42	1508.18
c Honey comb brickwork in leach pit	sq.m	6.0540	216.45	255.41	1546.26
d 75mm thk masonry partition in superstructure	sq.m	1.9838	119.4	140.89	279.49
e 115mm thick masonry in superstructure	sq.m	31.4593	199.00	234.82	7387.27
f 230mm thick masonry in superstructure	cu.m		1690.45	1994.73	
g Brick work in steps	cu.m	0.0480	1690.45	1994.73	95.75
h Dry brick work in paving	sq.m		80.85	95.40	0.00
5 RCC work					
a 1:2:4 RCC Plinth band	cu.m	0.2589	5209.75	6147.51	1591.34
b 1:2:4 RCC Lintel band (all types)	cu.m	0.1738	5209.75	6147.51	1068.44
c 1:2:4 PCC bed blocks for roof anchorage	cu.m	0.0198	2136.35	2520.89	50.01
6 Slab (Stone / precast RCC)					
a 125mm thk Slab under water tank	sq.m		570.79	673.53	
b 75mm thk Slab under hand wash areas (all)	sq.m	0.4940	342.47	404.11	199.63
c 50mm thk Partition shelves in storage	sq.m	0.4800	228.31	269.41	129.31
d 75mm thk Cover for water tank	sq.m		342.47	404.11	
e 75mm thk Cover for leach pit	sq.m	1.5386	342.47	404.11	621.77
7 Pointing and plastering					
a 1:4 pointing in exposed brick work	sq.m	26.0415	29.75	35.11	914.19
b 1:6 cement sand plastering	sq.m	27.5780	39.90	47.08	1298.43
c 1:6 cement sand with waterproof plastering	sq.m	1.3613	32.73	38.62	52.57
8 Flooring					
a Cement concrete flooring	sq.m	4.3553	143.85	169.74	739.28

cu.m – Cubic meter, sq.m – Square meter, m.m – Running meter

ITEM	UNIT	Quantity	Rate	Indexed rate	Amount
9 Tile work					
a Ceramic tile work in floor	sq.m	4.1569	504.10	594.84	2472.68
b Ceramic tile work in dado	sq.m	8.5725	504.10	594.84	5099.25
c Antiskid tiles in Ramp	sq.m	5.0153	406.15	479.26	2403.62
10 Sanitary fixtures					
a Rural squatting pan	number	1	350.00	413.00	413.00
b Girl's squatting urinal	number	2	300.00	354.00	708.00
11 Plumbing					
a GI pipe water supply line (internal) +3m external	m.m	4.0614	78.65	92.81	376.93
b Taps	number	3	250.00	295.00	885.00
c Waste water pipe for flushing	m.m	4.426	31.05	36.64	162.16
12 Sewage					
a Sewage line from squatting pan to first IC + 3m	m.m	3.881	111.60	131.69	511.08
b Waste drain line from urinal to first IC + 3m	m.m	3.721	111.60	131.69	490.01
13 Roof work					
a Roof area (sloping, with overhangs and overlaps)	sq.m	14.2619	700.00	700.00	9983.33
14 Doors					
a D1	number		500.00	590.00	
b D2	number	1	500.00	590.00	590.00
c D3	number	1	500.00	590.00	590.00
d D4	number		500.00	590.00	0.00
e D5	number	2	500.00	590.00	1180.00
f Storage door shutter	number		500.00	590.00	0.00
15 Ventilators					
a V1	number		350.00	413.00	0.00
b V2	number	1	350.00	413.00	413.00
c V3	number		350.00	413.00	
d V4	number	2	350.00	413.00	826.00
16 Incinerator					
a Metal / Masonry incinerator	number	1	1500.00	1500.00	1500.00
17 Painting work					
a Internal white washing	sq.m	27.578	35.40	41.77	1151.99
b External wall painting	sq.m	26.0415	30.00	35.40	921.87
c Door and ventilator	sq.m	11.6325	58	68.44	796.13
18 Metal Work					
a Grab bars in toilets 40mm dia MS pipe	m.m	4.1448	32.10	37.88	157.00
b Rail in 40mm dia MS pipe in ramp	m.m	18.8785	32.10	37.88	715.08
c Vertical rail supports 25mm dia MS bars	m.m	8.965	32.10	37.88	339.58

Total Amount Rs. 59311
Total Area Sq.m 7.35
Cost per sqm 8070

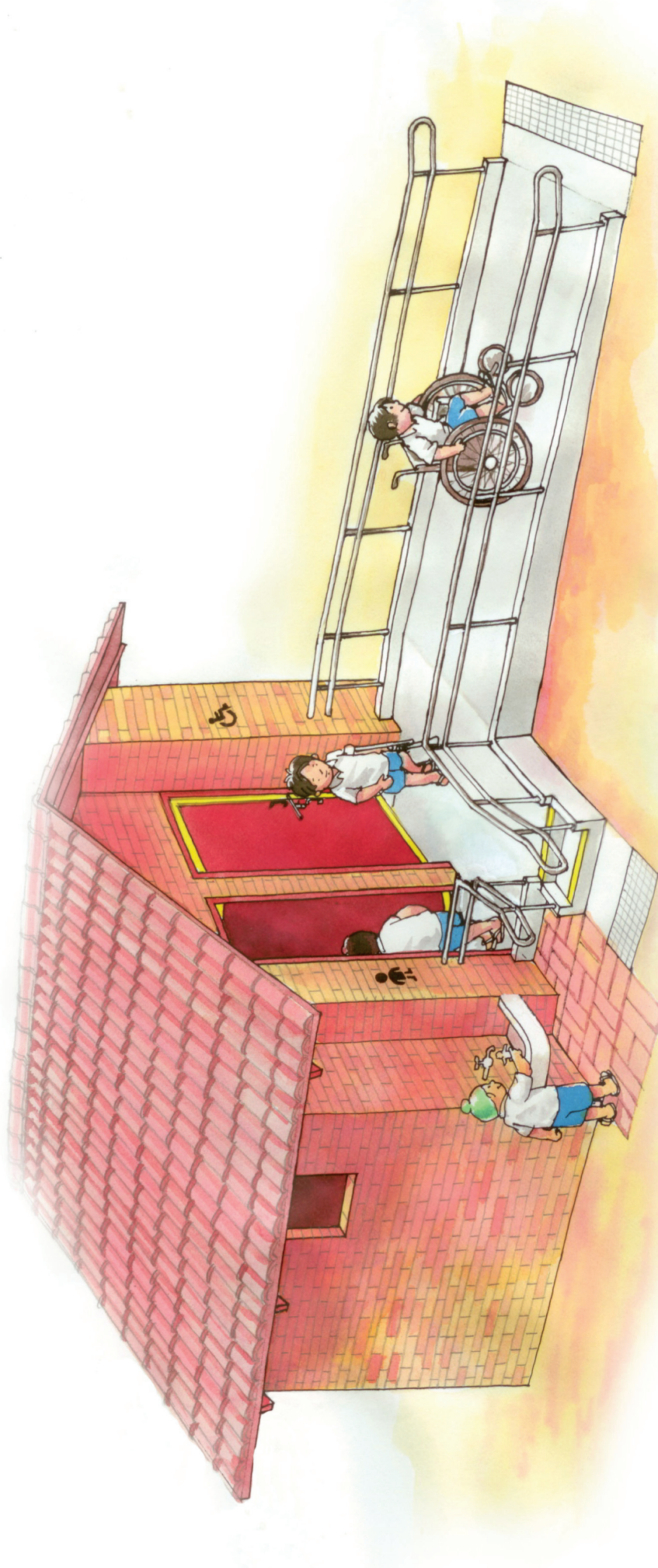

Basic Core Design for 80 Boys with provision for Children with Special Needs

Suitable when there is need of boy's toilet as well as CWSN toilet.

Total Built-up Area: 7.75 sq.m

Indicative cost* Rs 56,330

Additional salient features:

The design has:

1. Accessibility ramp and rails for CWSN.
2. One toilet for boys / CWSN with internal wash and provision of internal grab bars and rails.

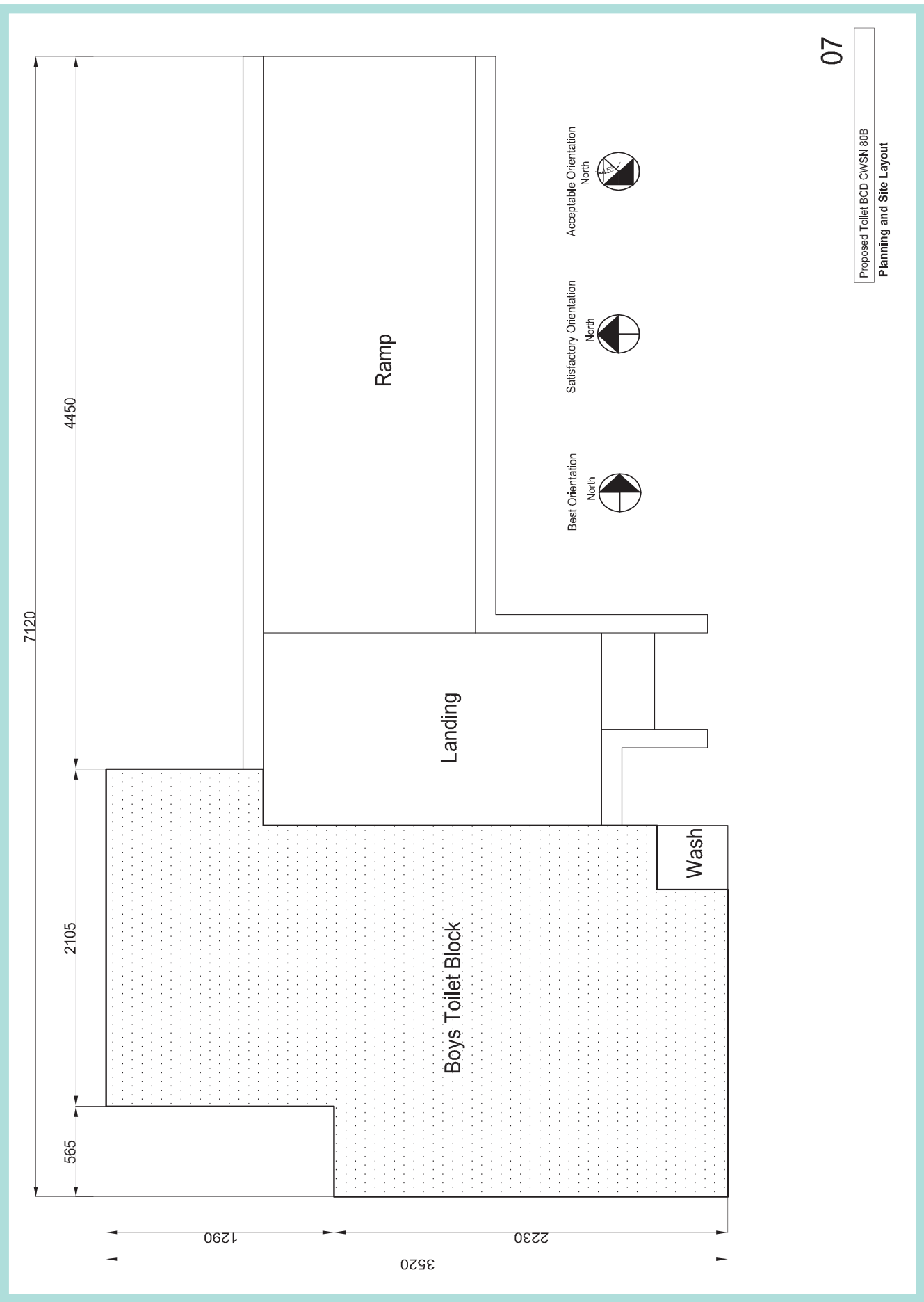

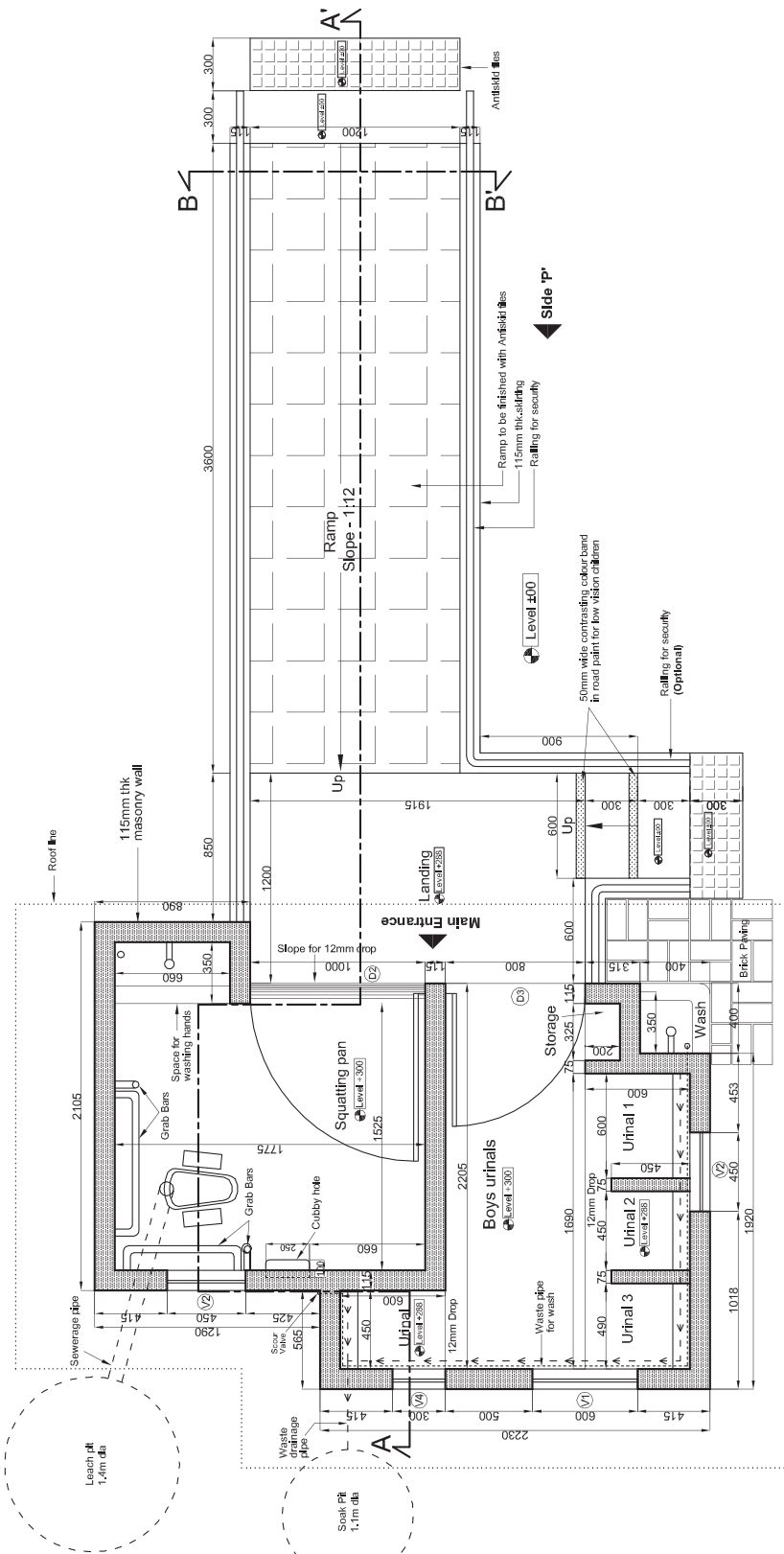

Area calculation		
Boys Toilet block		7.75 sqm
Landing+Steps		2.77 sqm
Ramp		5.12 sqm
Total Overall Area		15.64 sqm
Total Covered Area		7.75 sqm

Schedule of openings		
Name	Size w x h	Size w x h
D2	1000x2100	V1 600x450
D3	800x2100	V2 450x450
		V4 300x450

07

Proposed Toilet BCD CWSN 80B

Plan

Scale: 200 100 0 100 200 300

All dimensions are in mm

Notes

- This design is valid for brick strength not below 35kg/sq.cm.
- Foundation design is only indicative & may need review based on local site conditions.
- For masonry water tank, the foundation shall be in 230mm brick up to the base of the tank.
- Mortar 1:4 for 15mm thick masonry. No reinforcement bars in alternate courses.
- This design is valid for earth quake zone I, II & III regions only
- No water supply or waste water carrying pipe shall be concealed in the masonry wall. It shall be exposed and fixed with clips and not chased in masonry walls.
- In case the masonry specification is changed from that given here, maintain the internal clear dimensions & the layout and provide suitable redesigned foundation.
- Stopping roof overhang and its anchorage design may need review in cyclone prone regions.
- In case roof specifications are changed from that given here (e.g. flat roof in stone or RCC) provide suitable strengthening of masonry while maintaining all internal clearances in the layout design.
- Location of leach pits, soak pits, waste drainage pipes & inspection chamber to be decided based on site conditions.
- Minimum distance of leaching pit from building foundation to be 125cm in different soil types.
- Design of leach pit shown is for 80 children with its volume sufficient for catering approximately one year in different soil types. For higher capacity or longer duration, design will need review.

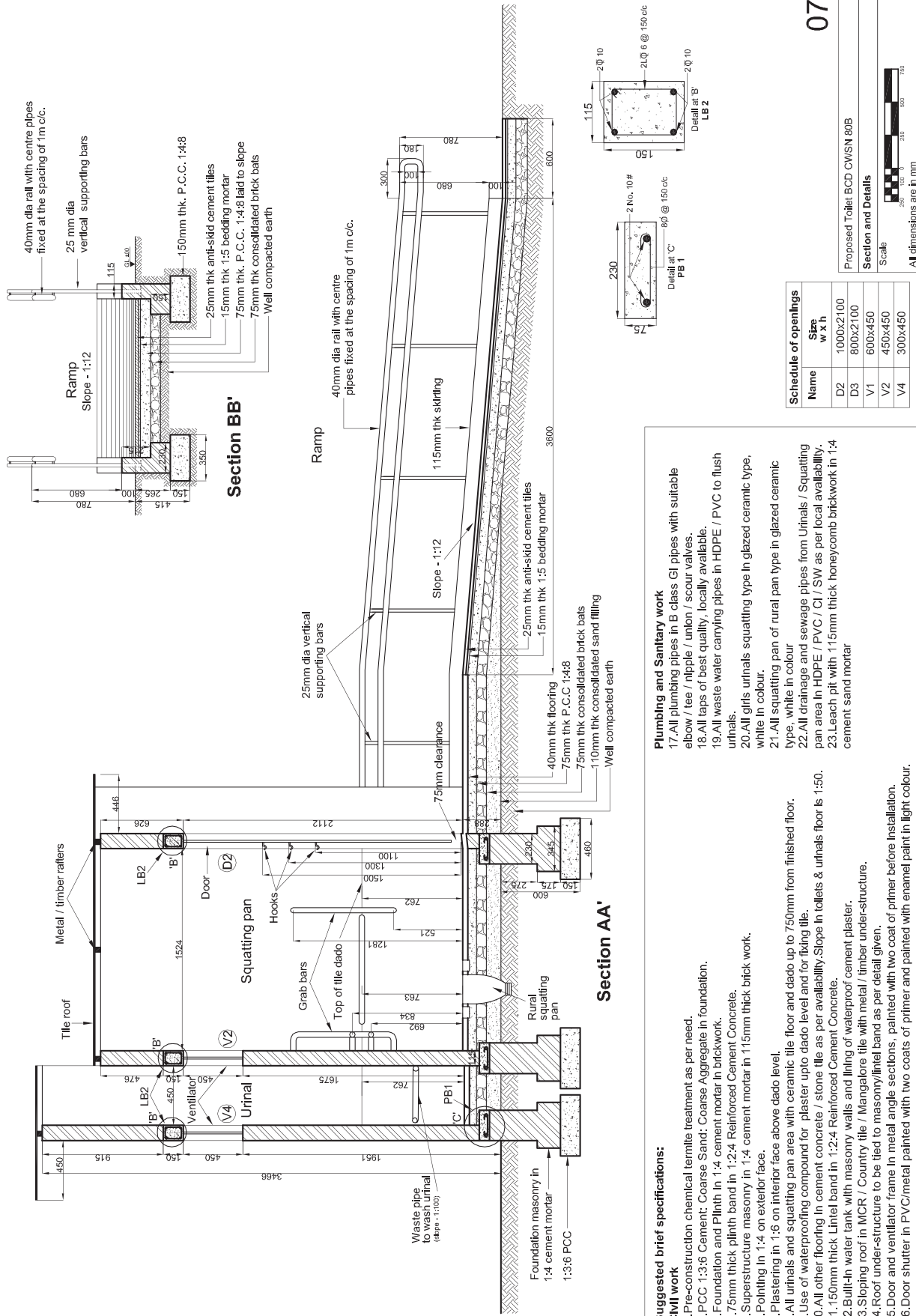

Suggested brief specifications:

- Civil work**
1. Pre-construction chemical termite treatment as per need.
 2. PCC 1:3:6 Cement: Coarse Sand: Coarse Aggregate in foundation.
 3. Foundation and Plinth in 1:4 cement mortar in brickwork.
 4. 75mm thick plinth band in 1:2:4 Reinforced Cement Concrete.
 5. Superstructure masonry in 1:4 cement mortar in 115mm thick brick work.
 6. Pointing in 1:4 on exterior face.
 7. Plastering in 1:6 on interior face above dado level.
 8. All urinals and squatting pan area with ceramic tile floor and dado up to 750mm from finished floor.
 9. Use of waterproofing compound for plaster upto dado level and for fixing tile.
 10. All other flooring in cement concrete / stone tile as per availability. Slope in toilets & urinals floor is 1:50.
 11. 150mm thick Lintel band in 1:2:4 Reinforced Cement Concrete.
 12. Built-in water tank with masonry walls and lining of waterproof cement plaster.
 13. Sloping roof in MCR / Country tile / Mangalore tile with metal / timber under-structure.
 14. Roof under-structure to be tied to masonry/lintel band as per detail given.
 15. Door and ventilator frame in metal angle sections, painted with two coats of primer before installation.
 16. Door shutter in PVC/metal painted with two coats of primer and painted with enamel paint in light colour.

Plumbing and Sanitary work

17. All plumbing pipes in B class GI pipes with suitable elbow / tee / nipple / union / scour valves.
18. All taps of best quality, locally available.
19. All waste water carrying pipes in HDPE / PVC to flush urinals.
20. All girls urinals squatting type in glazed ceramic type, white in colour.
21. All squatting pan of rural pan type in glazed ceramic type, white in colour.
22. All drainage and sewage pipes from Urinals / Squatting pan area in HDPE / PVC / GI / SW as per local availability.
23. Leach pit with 115mm thick honeycomb brickwork in 1:4 cement sand mortar.

Schedule of openings	
Name	Size w x h
D2	1000x2100
D3	800x2100
V1	600x450
V2	450x450
V4	300x450

Proposed Toilet BCD CWSN 80B

Section and Details

Scale

All dimensions are in mm

07

07

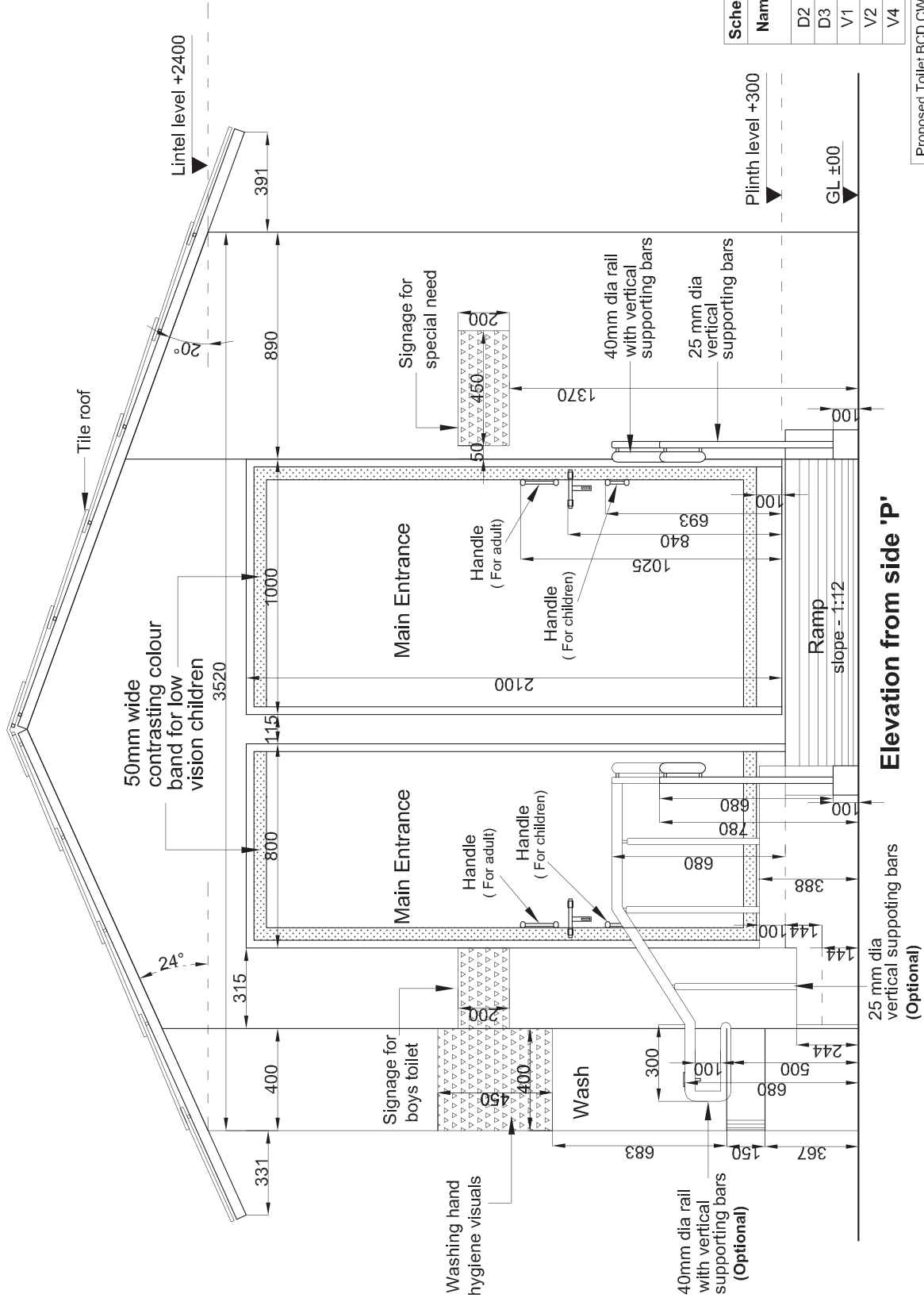

Schedule of openings	
Name	Size w x h
D2	1000x2100
D3	800x2100
V1	600x450
V2	450x450
V4	300x450

Proposed Toilet BCD CWSN 80B

Elevation

Scale
 100 200 300
 100 200 300

All dimensions are in mm

Elevation from side 'P'

25 mm dia vertical supporting bars (Optional)

Bill of quantities – 07 BCD CWSN 80B

ITEM	UNIT	Quantity	Rate	Indexed rate	Amount
9	Tile work				
a	Ceramic tile work in floor	sq.m	4.2694	504.10	594.84
b	Ceramic tile work in dado	sq.m	9.480975	504.10	594.84
c	Antiskid tiles in Ramp	sq.m	4.9446	406.15	479.26
10	Sanitary fixtures				
a	Rural squatting pan	number	1	350.00	413.00
b	Girl's squatting urinal	number		300.00	354.00
11	Plumbing				
a	GI pipe water supply line (internal) +3m external	rn.m	9.126	78.65	92.81
b	Taps	number	3	250.00	295.00
c	Waste water pipe for flushing	rn.m	4.347	31.05	36.64
12	Sewage				
a	Sewage line from squatting pan to first IC + 3m	rn.m	4.1315	111.60	131.69
b	Waste drain line from urinal to first IC + 3m	rn.m	3.46	111.60	131.69
13	Roof work				
a	Roof area (sloping, with overhangs and overlaps)	sq.m	14.0142	700.00	700.00
14	Doors				
a	D1	number		500.00	590.00
b	D2	number		500.00	590.00
c	D3	number	1	500.00	590.00
d	D4	number	1	500.00	590.00
e	D5	number		500.00	590.00
f	Storage door shutter	number		500.00	590.00
15	Ventilators				
a	V1	number	1	350.00	413.00
b	V2	number	2	350.00	413.00
c	V3	number		350.00	413.00
d	V4	number	1	350.00	413.00
16	Incinerator				
a	Metal / Masonry incinerator	number		1500.00	1500.00
17	Painting work				
a	Internal white washing	sq.m	25.2175	35.40	41.77
b	External wall painting	sq.m	26.979	30.00	35.40
c	Door and ventilator	sq.m	8.37	58	68.44
18	Metal Work				
a	Grab bars in toilets 40mm dia MS pipe	rn.m	4.1448	32.10	37.88
b	Rail in 40mm dia MS pipe in ramp	rn.m	20.5861	32.10	37.88
c	Vertical rail supports 25mm dia MS bars	rn.m	10.595	32.10	37.88

Total Amount Rs. 56330
Total Area Sq.m 7.75
Cost per sqm 7268

ITEM	UNIT	Quantity	Rate	Indexed rate	Amount
1	Excavation				
a	Foundation	cu.m	3.9082	30.00	138.35
b	Leach and soak pit	cu.m	4.2076	30.00	148.95
c	Ramp work	cu.m	2.8272	30.00	100.08
2	PCC				
a	1:3:6 PCC in foundation	cu.m	0.9770	1678.00	1934.58
b	1:4:8 PCC in flooring	cu.m	0.4624	1503.60	820.49
c	1:4:8 PCC in Ramp	cu.m	1.0916	1503.60	1936.77
3	Back-filling				
a	Foundation	cu.m	1.1753	25.55	30.15
b	Sand fill under floor	cu.m	0.7992	95.60	112.81
c	Consolidated aggregate under floor	cu.m	0.9208		0.00
d	Infill in soak pit	cu.m	1.8997	25.55	30.15
e	Back fill in Ramp	cu.m	0.0591	25.55	30.15
4	Brick work				
a	Brick work in foundation and plinth	cu.m	2.0249	1452.9	1714.42
b	Brickwork in Ramp	cu.m	0.8088	1452.90	1714.42
c	Honey comb brickwork in leach pit	sq.m	6.0540	216.45	255.41
d	75mm thk masonry partition in superstructure	sq.m	1.9088	119.4	140.89
e	115mm thick masonry in superstructure	sq.m	31.9948	199.00	234.82
f	230mm thick masonry in superstructure	cu.m		1690.45	1994.73
g	Brick work in steps	cu.m	0.0374	1690.45	1994.73
h	Dry brick work in paving	sq.m	0.6293	80.85	95.40
5	RCC work				
a	1:2:4 RCC Plinth band	cu.m	0.2436	5209.75	6147.51
b	1:2:4 RCC Lintel band (all types)	cu.m	0.1609	5209.75	6147.51
c	1:2:4 PCC bed blocks for roof anchorage	cu.m	0.0179	2136.35	2520.89
6	Slab (Stone / precast RCC)				
a	125mm thk Slab under water tank	sq.m		570.79	673.53
b	75mm thk Slab under hand wash areas (all)	sq.m	0.4840	342.47	404.11
c	50mm thk Partition shelves in storage	sq.m	0.3188	228.31	269.41
d	75mm thk Cover for water tank	sq.m		342.47	404.11
e	75mm thk Cover for leach pit	sq.m	1.5386	342.47	404.11
7	Pointing and plastering				
a	1:4 pointing in exposed brick work	sq.m	26.9790	29.75	35.11
b	1:6 cement sand plastering	sq.m	25.2175	39.90	47.08
c	1:6 cement sand with waterproof plastering	sq.m	1.8863	32.73	38.62
8	Flooring				
a	Cement concrete flooring	sq.m	4.0620	143.85	169.74

cu.m – Cubic meter, sq.m – Square meter, rn.m – Running meter

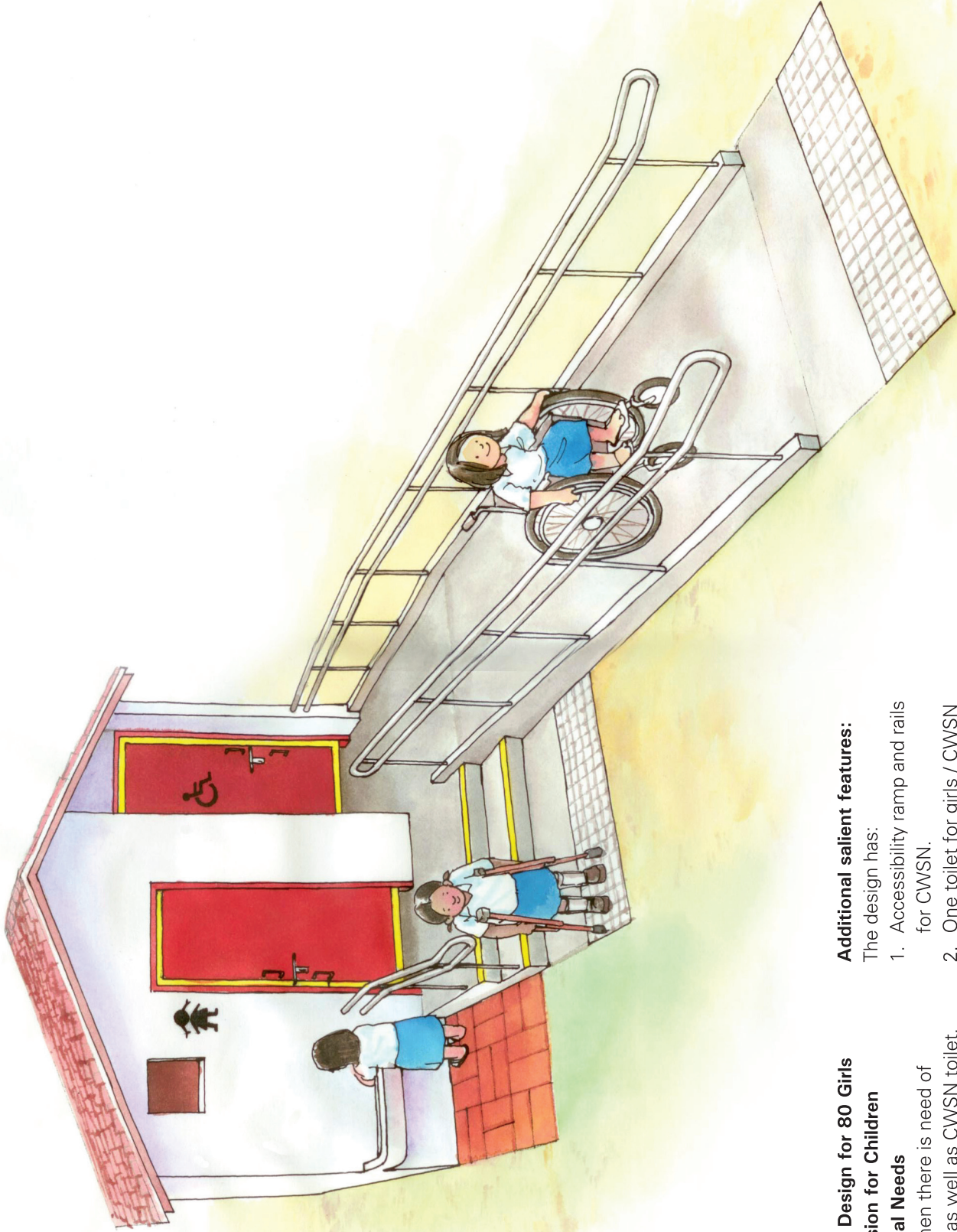

Basic Core Design for 80 Girls with provision for Children With Special Needs

Suitable when there is need of Girl's toilet as well as CWSN toilet.

Total Built-up Area: 10.08 sq.m

Indicative cost Rs 75.672

Additional salient features:

The design has:

1. Accessibility ramp and rails for CWSN.
2. One toilet for girls / CWSN with internal wash and provision of internal grab bars and rails.

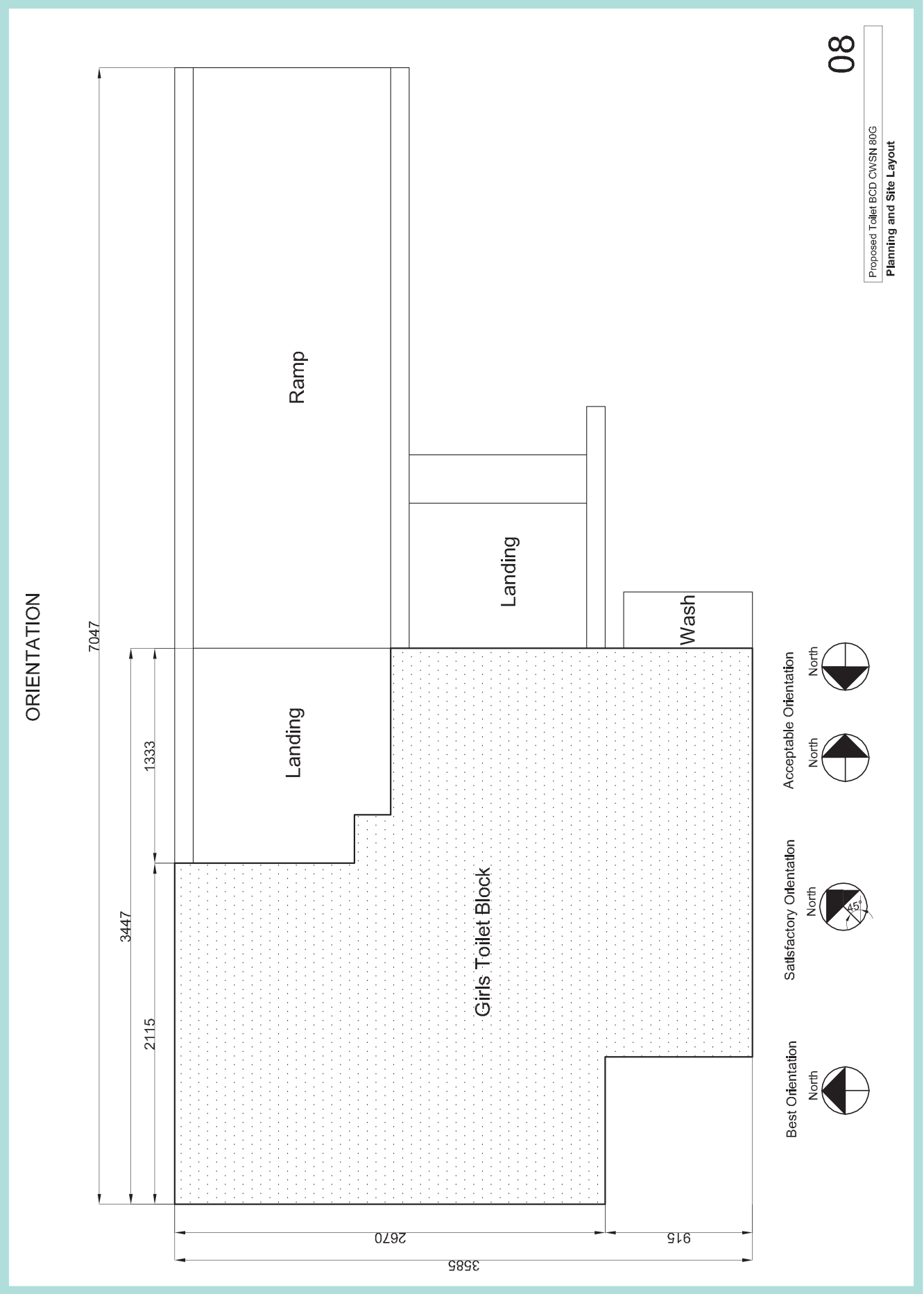

08

Proposed Toilet BCD CWSN 80G
 Planning and Site Layout

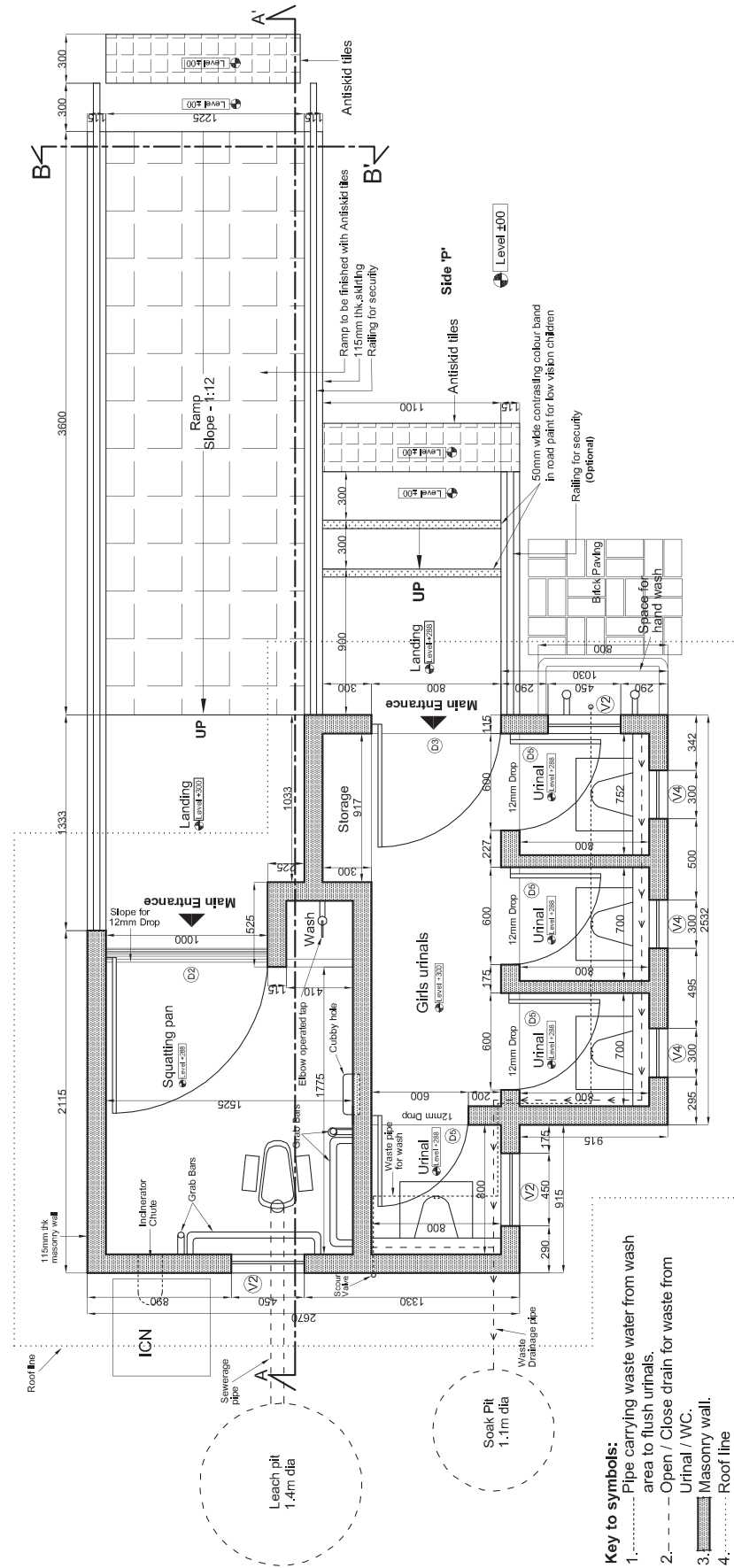

- Key to symbols:**
- Pipe carrying waste water from wash area to flush urinals.
 - - - - Open / Close drain for waste from Urinal / WC.
 - ▬ Masonry wall.
 - Roof line

Notes

- This design is valid for brick strength not below 35kg/sq.cm.
- Foundation design is only indicative & may need review based on local site conditions.
- For masonry water tank, the foundation shall be in 230mm brick up to the base of the tank.
- Mortar 1:4 for 115mm thick masonry. No reinforcement bars in alternate courses.
- This design is valid for earth quake zone I, II & III regions only
- No water supply or waste water carrying pipe shall be concealed in the masonry wall. It shall be exposed and fixed with clips and not chased in masonry walls.
- In case the masonry specification is changed from that given here, maintain the internal clear dimensions and the layout and provide suitable redesigned foundation.
- Sloping roof overhang and its anchorage design may need review in cyclone prone regions.
- In case roof specifications are changed from that given here (e.g. flat roof in stone or RCC) provide suitable strengthening of masonry while maintaining all internal clearances in the layout design.
- Only one metallic / masonry incinerator to be put along the location indicative as ICN.
- Incinerator to be provided only with Girl's toilet and to have chute from inside.
- Location of leach pits, soak pits, waste drainage pipes & inspection chamber is indicated only. Actual location to be decided based on site conditions.
- Minimum distance of leaching pit from building foundation to be 125cm in different soil types.
- Design of leach pit shown is for 80 children with its volume sufficient for catering approximately one year in different soil types. For higher capacity or longer duration, design will need review.

Area calculation

Girls toilet block	9.8 sqm
Landing+Steps	3.52 sqm
Wash	0.28 sqm
Ramp	5.23 sqm
Total Overall Area	18.83 sqm
Total Covered Area	10.08 sqm

Schedule of openings

Name	Size w x h	Name	Size w x h
D2	1000x2100	V2	450x450
D3	800x1500	V4	300x450
D5	600x2100		

Proposed Toilet BCD CWSN 80G

Plan

Scale: 1:100 (1:250, 1:500, 1:750)

All dimensions are in mm

08

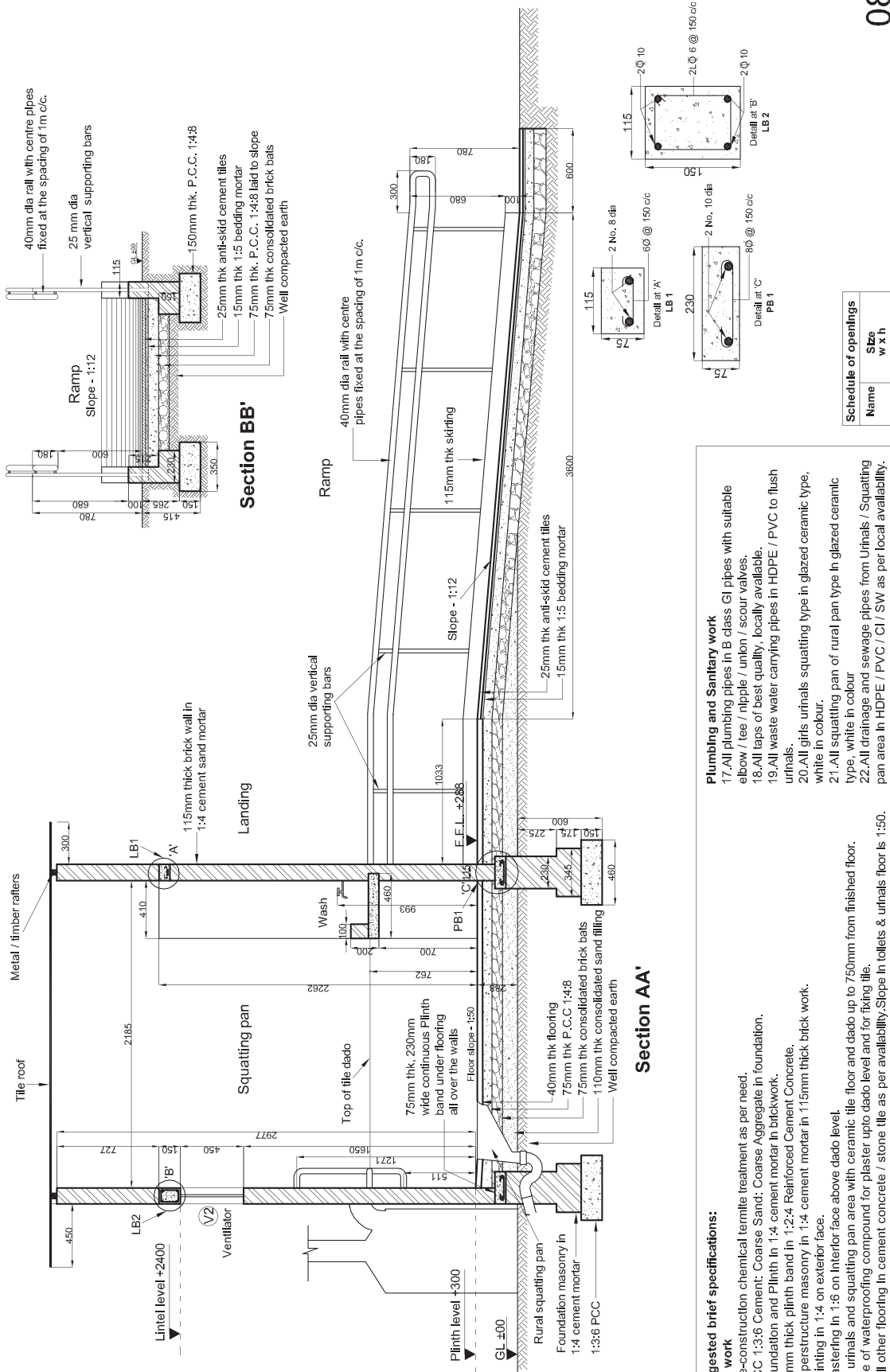

08

Schedule of openings	
Name	Size w x h
D2	1000x2100
D3	800x2100
D5	600x1500
V2	450x450
V4	300x450

Section and Details	
Scale	
All dimensions are in mm	

Proposed Toilet BCD CWSN 80G

- Suggested brief specifications:**
- Civil work**
1. Pre-construction chemical termite treatment as per need.
 2. PCC 1:3:6 Cement: Coarse Sand: Coarse Aggregate in foundation.
 3. Foundation and Plinth in 1:4 cement mortar in brickwork.
 4. 75mm thick plinth band in 1:2:4 Reinforced Cement Concrete.
 5. Superstructure masonry in 1:4 cement mortar in 115mm thick brick work.
 6. Pointing in 1:4 on exterior face.
 7. Plastering in 1:6 on interior face above dado level.
 8. All urinals and squatting pan area with ceramic tile floor and dado up to 750mm from finished floor.
 9. Use of waterproofing compound for plaster upto dado level and for fixing tile.
 10. All other flooring in cement concrete / stone tile as per availability. Slope in toilets & urinals floor is 1:50.
 11. 150mm thick Lintel band in 1:2:4 Reinforced Cement Concrete.
 12. Bull-in water tank with masonry walls and lining of waterproof cement plaster.
 13. Slipping roof in MCR / Country tile / Mangalore tile with metal / timber under-structure.
 14. Roof under-structure to be tied to masonry/lintel band as per detail given.
 15. Door and ventilator frame in metal angle sections, painted with two coats of primer before installation.
 16. Door shutter in PVC/metal painted with two coats of primer and painted with enamel paint in light colour.
- Plumbing and Sanitary work**
17. All plumbing pipes in B class GI pipes with suitable elbow / tee / nipple / union / scour valves.
 18. All taps of best quality, locally available.
 19. All waste water carrying pipes in HDPE / PVC to flush urinals.
 20. All girls urinals squatting type in glazed ceramic type, white in colour.
 21. All squatting pan of rural pan type in glazed ceramic type, white in colour.
 22. All drainage and sewage pipes from Urinals / Squatting pan area in HDPE / PVC / CI / SW as per local availability.
 23. Leach pit with 115mm thick honeycomb brickwork in 1:4 cement sand mortar.

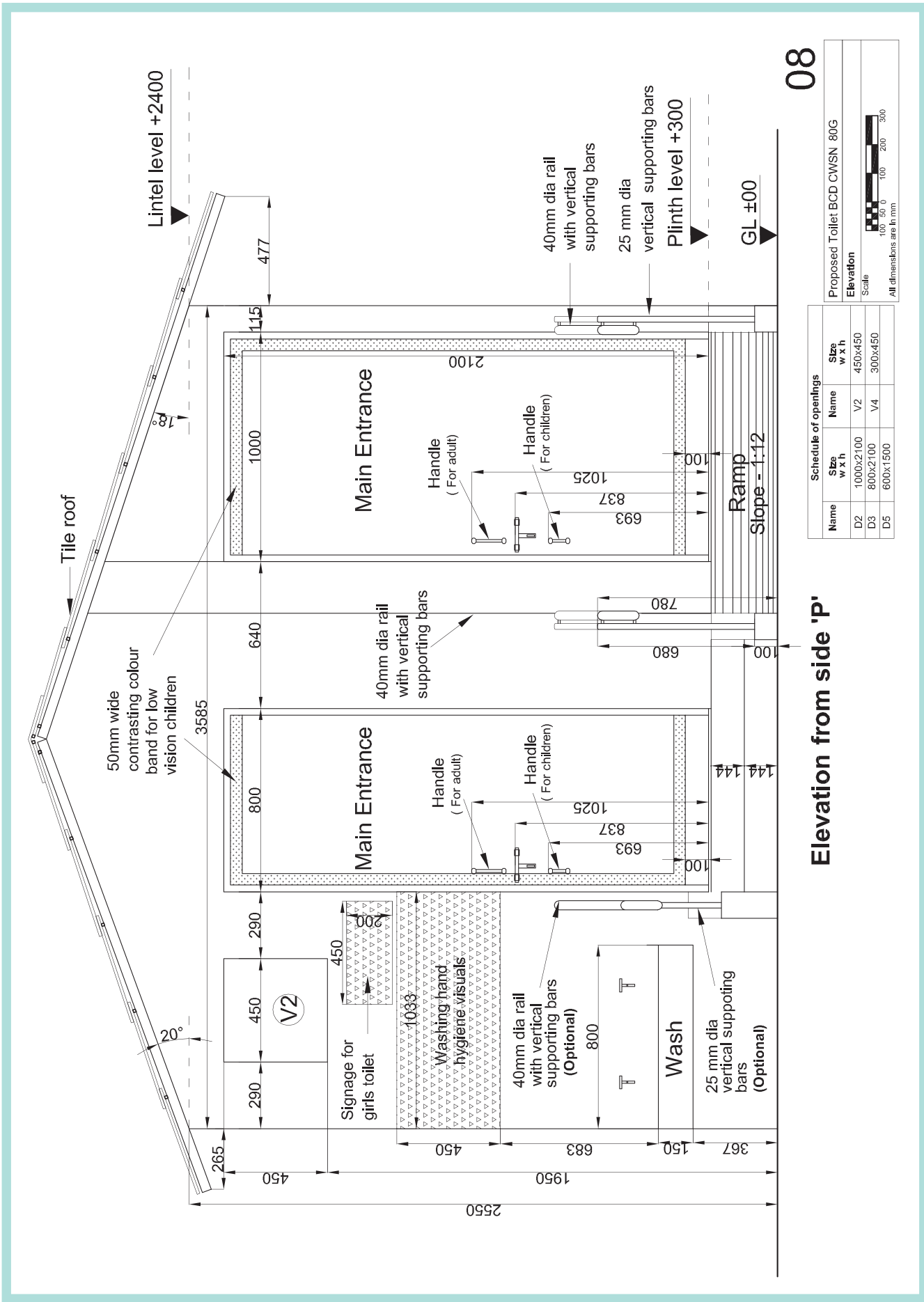

08

Elevation from side 'P'

Proposed Toilet BCD CWSN 80G

Name	Size w x h	Name	Size w x h
D2	1000x2100	V2	450x450
D3	800x2100	V4	300x450
D5	600x1500		

Scale: 1:50, 1:100, 1:200, 1:300
All dimensions are in mm

Schedule of openings

Name	Size w x h	Name	Size w x h
D2	1000x2100	V2	450x450
D3	800x2100	V4	300x450
D5	600x1500		

Bill of quantities – 08 BCD CWSN 80G

ITEM	UNIT	Quantity	Rate	Indexed rate	Amount
9	Tile work				
a	Ceramic tile work in floor	sq.m	5.352	504.10	594.84
b	Ceramic tile work in dado	sq.m	12.24375	504.10	594.84
c	Antiskid tiles in Ramp	sq.m	5.1508	406.15	479.26
10	Sanitary fixtures				
a	Rural squatting pan	number	1	350.00	413.00
b	Girl's squatting urinal	number	4	300.00	1416.00
11	Plumbing				
a	GI pipe water supply line (internal) +3m external	rn.m	7.9537	78.65	92.81
b	Taps	number	4	250.00	1180.00
c	Waste water pipe for flushing	rn.m	5.3887	31.05	36.64
12	Sewage				
a	Sewage line from squatting pan to first IC + 3m	rn.m	4.2183	111.60	131.69
b	Waste drain line from urinal to first IC + 3m	rn.m	3.7094	111.60	131.69
13	Roof work				
a	Roof area (sloping, with overhangs and overlaps)	sq.m	16.9948	700.00	700.00
14	Doors				
a	D1	number	1	500.00	590.00
b	D2	number	1	500.00	590.00
c	D3	number	1	500.00	590.00
d	D4	number	0	500.00	590.00
e	D5	number	4	500.00	2360.00
f	Storage door shutter	number	0	500.00	590.00
15	Ventilators				
a	V1	number	3	350.00	413.00
b	V2	number	3	350.00	413.00
c	V3	number	3	350.00	413.00
d	V4	number	3	350.00	413.00
16	Incinerator				
a	Metal / Masonry incinerator	number	1	1500.00	1500.00
17	Painting work				
a	Internal white washing	sq.m	34.3935	35.40	41.77
b	External wall painting	sq.m	31.0758	30.00	35.40
c	Door and ventilator	sq.m	15.7725	58	68.44
18	Metal Work				
a	Grab bars in toilets 40mm dia MS pipe	rn.m	4.1448	32.10	37.88
b	Rail in 40mm dia MS pipe in ramp	rn.m	19.3621	32.10	37.88
c	Vertical rail supports 25mm dia MS bars	rn.m	8.965	32.10	37.88

Total Amount Rs. 75672
Total Area Sq.m 10.08
Cost per sqm 7507

ITEM	UNIT	Quantity	Rate	Indexed rate	Amount
1	Excavation				
a	Foundation	cu.m	5.6097	30.00	198.58
b	Leach and soak pit	cu.m	4.2076	30.00	148.95
c	Ramp work	cu.m	1.4359	30.00	50.83
2	PCC				
a	1:3:6 PCC in foundation	cu.m	1.3597	1678.00	2692.22
b	1:4:8 PCC in flooring	cu.m	0.7315	1503.60	1297.90
c	1:4:8 PCC in Ramp	cu.m	1.2851	1503.60	2280.09
3	Back-filling				
a	Foundation	cu.m	1.6356	25.55	49.31
b	Sand fill under floor	cu.m	0.8414	95.60	94.92
c	Consolidated aggregate under floor	cu.m	0.7415	0.00	0.00
d	Infill in soak pit	cu.m	1.8997	25.55	57.27
e	Back fill in Ramp	cu.m	0.0591	25.55	1.78
4	Brick work				
a	Brickwork in foundation and plinth	cu.m	2.8179	1452.9	4831.05
b	Brickwork in Ramp	cu.m	0.7780	1452.90	1333.82
c	Honey comb brickwork in leach pit	sq.m	6.0540	216.45	1546.26
d	75mm thk masonry partition in superstructure	sq.m	2.7450	119.4	386.75
e	115mm thick masonry in superstructure	sq.m	39.8101	199.00	9348.21
f	230mm thick masonry in superstructure	cu.m		1690.45	1994.73
g	Brick work in steps	cu.m	0.3674	1690.45	1994.73
h	Dry brick work in paving	sq.m	0.6750	80.85	64.39
5	RCC work				
a	1:2:4 RCC Plinth band	cu.m	0.3389	5209.75	2083.60
b	1:2:4 RCC Lintel band (all types)	cu.m	0.2411	5209.75	1482.26
c	1:2:4 PCC bed blocks for roof anchorage	cu.m	0.0298	2136.35	75.01
6	Slab (Stone / precast RCC)				
a	125mm thk Slab under water tank	sq.m	570.79	673.53	
b	75mm thk Slab under hand wash areas (all)	sq.m	0.5546	342.47	404.11
c	50mm thk Partition shelves in storage	sq.m	1.0679	228.31	269.41
d	75mm thk Cover for water tank	sq.m	342.47	404.11	
e	75mm thk Cover for leach pit	sq.m	1.5386	342.47	621.77
7	Pointing and plastering				
a	1:4 pointing in exposed brick work	sq.m	31.0758	29.75	35.11
b	1:6 cement sand plastering	sq.m	34.3935	39.90	47.08
c	1:6 cement sand with waterproof plastering	sq.m	1.5653	32.73	60.45
8	Flooring				
a	Cement concrete flooring	sq.m	4.8748	143.85	169.74

cu.m – Cubic meter, sq.m – Square meter, rn.m – Running meter



Basic Core Design of combined toilet block for 40 Girls and 40 Boys on a site with Linear space to make the toilets

Suitable when a combined toilet block for Girls and Boys is needed and the space available is elongated in shape.

Total Built-up Area: 9.88 sq.m
Indicative cost* Rs 73,328

Additional salient features:

The design has:

1. Segregated entrances for girl's and boy's toilet blocks.
2. One toilet for girls with internal wash
3. Two girl's urinals
4. One toilet for boys with internal wash
5. Two boy's urinals
6. One thick partition wall between boys and girl's toilet area.
7. One common external wash with provision for storage water tank.

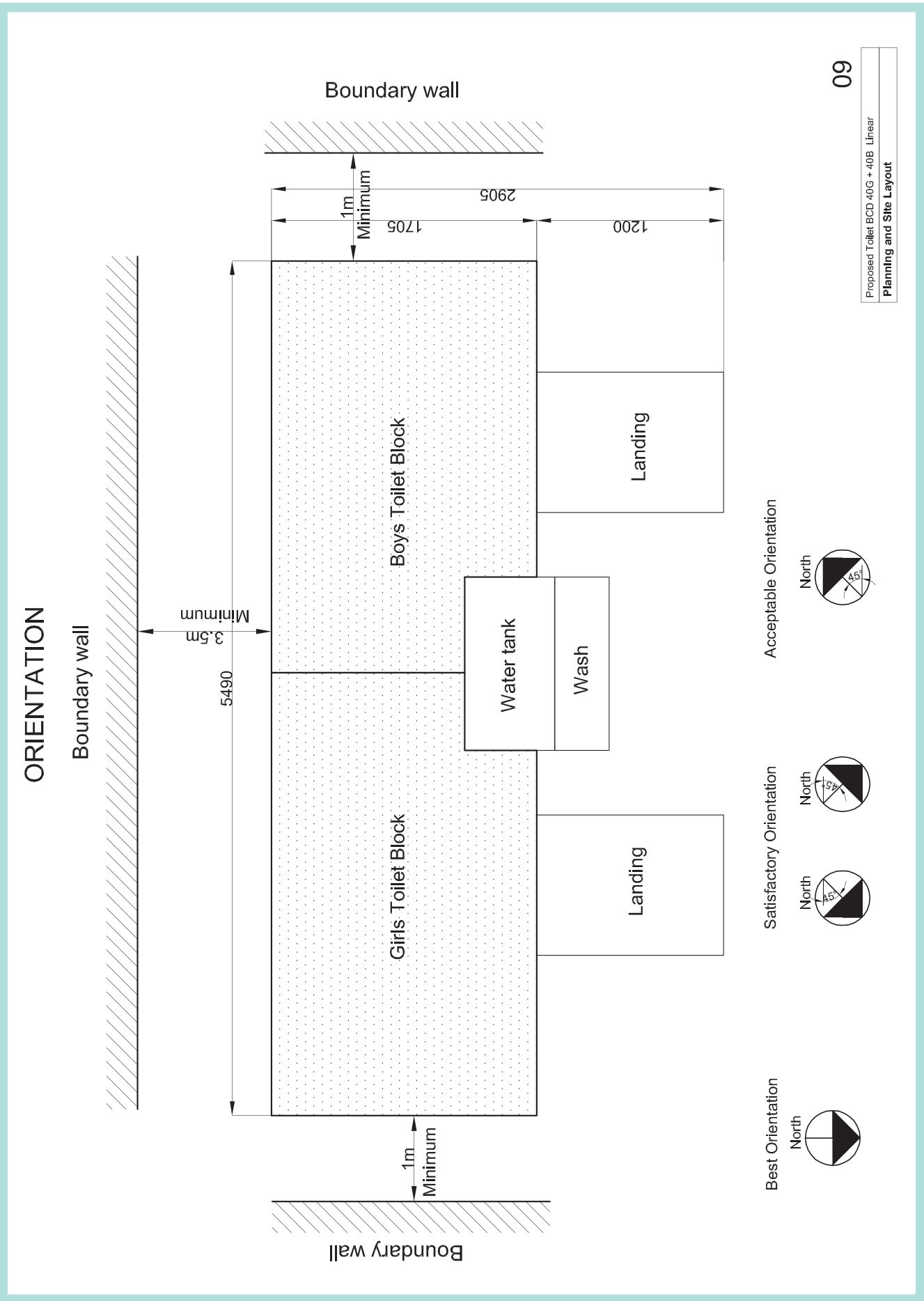

09

Proposed Toilet BCD 40G + 40B Linear
Planning and Site Layout

Plan – 09 BCD Linear 40G+40B

Schedule of openings		Area calculation	
Name	Size w x h	Boys toilet block	4.08 sqm
D3	800x2100	Girls toilet block	4.76 sqm
D4	700x2100	Water tank	0.65 sqm
D5	600x1500	Wash area	0.39 sqm
V1	600x450	Landing+Steps	2.18 sqm
V2	450x450	Total Overall Area	12.84 sqm
		Total Covered Area	9.88 sqm

- Notes**
- This design is valid for brick strength not below 35kg/sq.cm.
 - Foundation design is only indicative & may need review based on local site conditions.
 - For masonry water tank, the foundation shall be in 230mm brick up to the base of the tank.
 - Mortar 1:4 for 115mm thick masonry. No reinforcement bars in alternate courses.
 - This design is valid for earth quake zone I, II and III only.
 - No water supply or waste water carrying pipe shall be concealed in the masonry wall. It shall be exposed and fixed with clips and not chased in masonry walls.
 - In case the masonry specification is changed from that given here, maintain the internal clear dimensions & the layout and provide suitable redesigned foundation.
 - Stopping roof overhang and its anchorage design may need review in cyclone prone regions.
 - In case roof specifications are changed from that given here (e.g. flat roof in stone or RCC provide suitable strengthening of masonry while maintaining all internal clearances in the layout design.
 - Only one metallic / masonry incinerator to be put along the location indicated as ICN.
 - Incinerator to be provided only with Girls toilet and to have chute from inside.
 - Location of leach pits, soak pits, waste drainage pipes & inspection chamber is indicative only. Actual location to be decided based on site conditions.
 - Minimum distance of leaching pit from building foundation to be 125cm in different soil types.
 - Design of leach pit shown is for 40+40=80 children with its volume sufficient for catering approximately one year in different soil types. For higher capacity or longer duration, design will need review.

Key to symbols:

- Pipe carrying waste water from wash area to flush urinals.
- - - - Open / Covered drain for waste from Urinal / Squatting pan.
- ▨ Masonry wall.
- Roof line

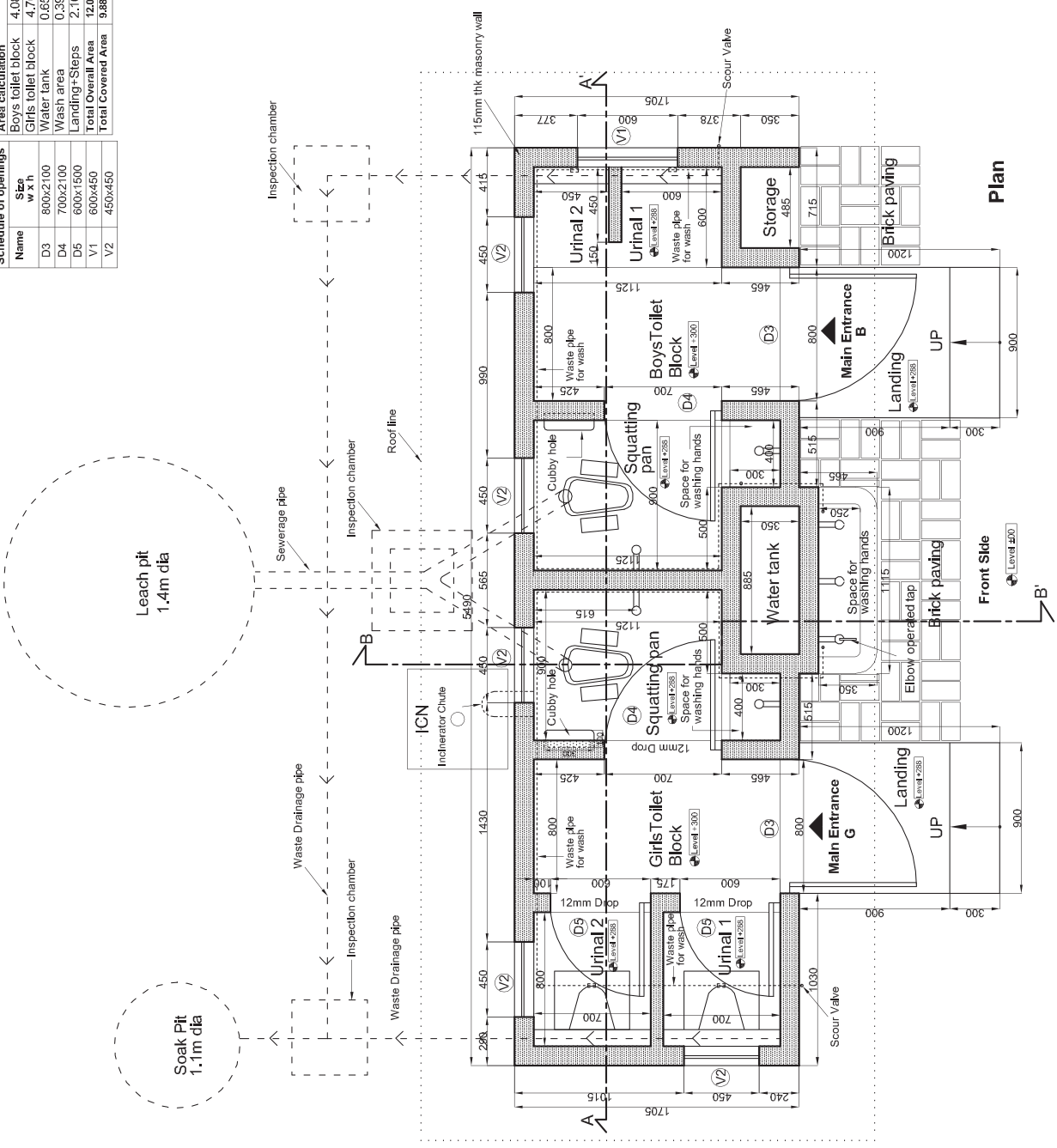

09

Proposed Toilet Basic Core Design 40 G+ 40 B Linear

Plan

Scale: 0 250 500 750
 Dimensions in mm

North

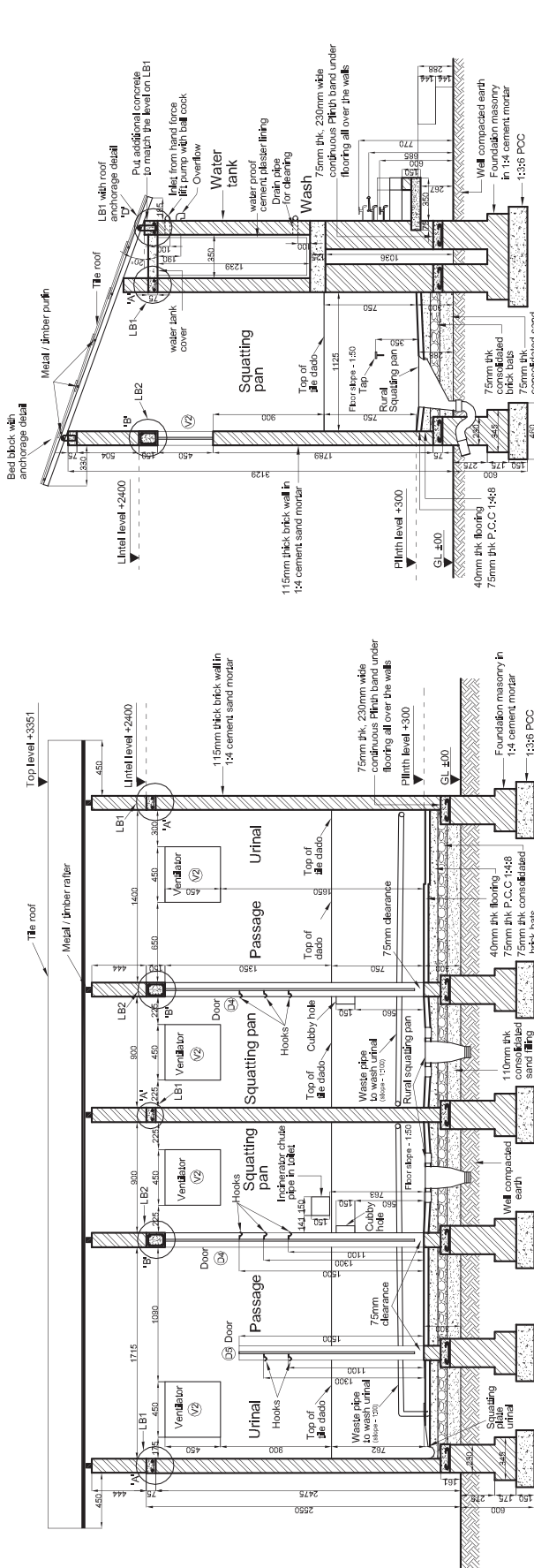

Girls Toilet Block
Section AA'

Boys Toilet Block
Section BB'

Name	Size w x h
D1	600x2100
D2	700x2100
D3	600x1600
V1	600x450
V2	450x450

Suggested brief specifications:

- Civil work**
1. Pre-construction chemical termite treatment as per need.
 2. PCC 1:3:6 Cement: Coarse Sand: Coarse Aggregate in foundation.
 3. Foundation and Plinth in 1:4 cement mortar in brickwork.
 4. 75mm thick plinth band in 1:2:4 Reinforced Cement Concrete.
 5. Superstructure masonry in 1:4 cement mortar in 115mm thick brick work.
 6. Pointing in 1:4 on exterior face.
 7. Plastering in 1:6 on interior face above dado level.
 8. All urinals and squatting pan area with ceramic tile floor and dado up to 750mm from finished floor.
 9. Use of waterproofing compound for plaster upto dado level and for fixing tile.
 10. All other flooring in cement concrete / stone tile as per availability. Slope in toilets & urinals floor is 1:50.
 11. 150mm thick Lintel band in 1:2:4 Reinforced Cement Concrete.
 12. Built-in water tank with masonry walls and lining of waterproof cement plaster.
 13. Sloping roof in MCR / Country tile / Mangalore tile with metal / timber under-structure.
 14. Roof under-structure to be tied to masonry/lintel band as per detail given.
 15. Door and ventilator frame in metal angle sections, painted with two coats of primer before installation.
 16. Door shutter in PVC/metal painted with two coats of primer and painted with enamel paint in light colour.

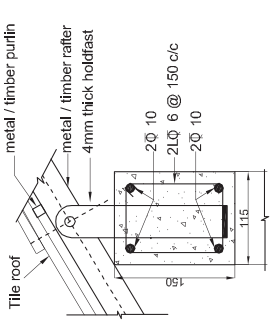
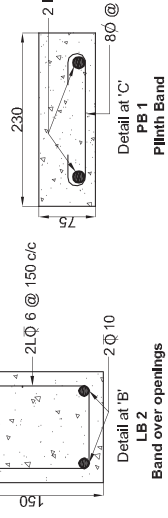

Plumbing and Sanitary work

17. All plumbing pipes in B class GI pipes with suitable elbow / tee / nipple / union / scour valves.
18. All taps of best quality, locally available.
19. All waste water carrying pipes in HDPE / PVC to flush urinals.
20. All girls urinals squatting type in glazed ceramic type, white in colour.
21. All squatting pan of rural pan type in glazed ceramic type, white in colour
22. All drainage and sewage pipes from urinals / Squatting pan area in HDPE / PVC / CI / SW as per local availability.
23. Leach pit with 115mm thick honeycomb brickwork in 1:4 cement sand mortar

Proposed Toilet Basic Core Design 40 G+ 40 B Linear

Sections and Details

Scale: 1:100, 1:200, 1:400, 1:800, 1:1600

All dimensions are in mm

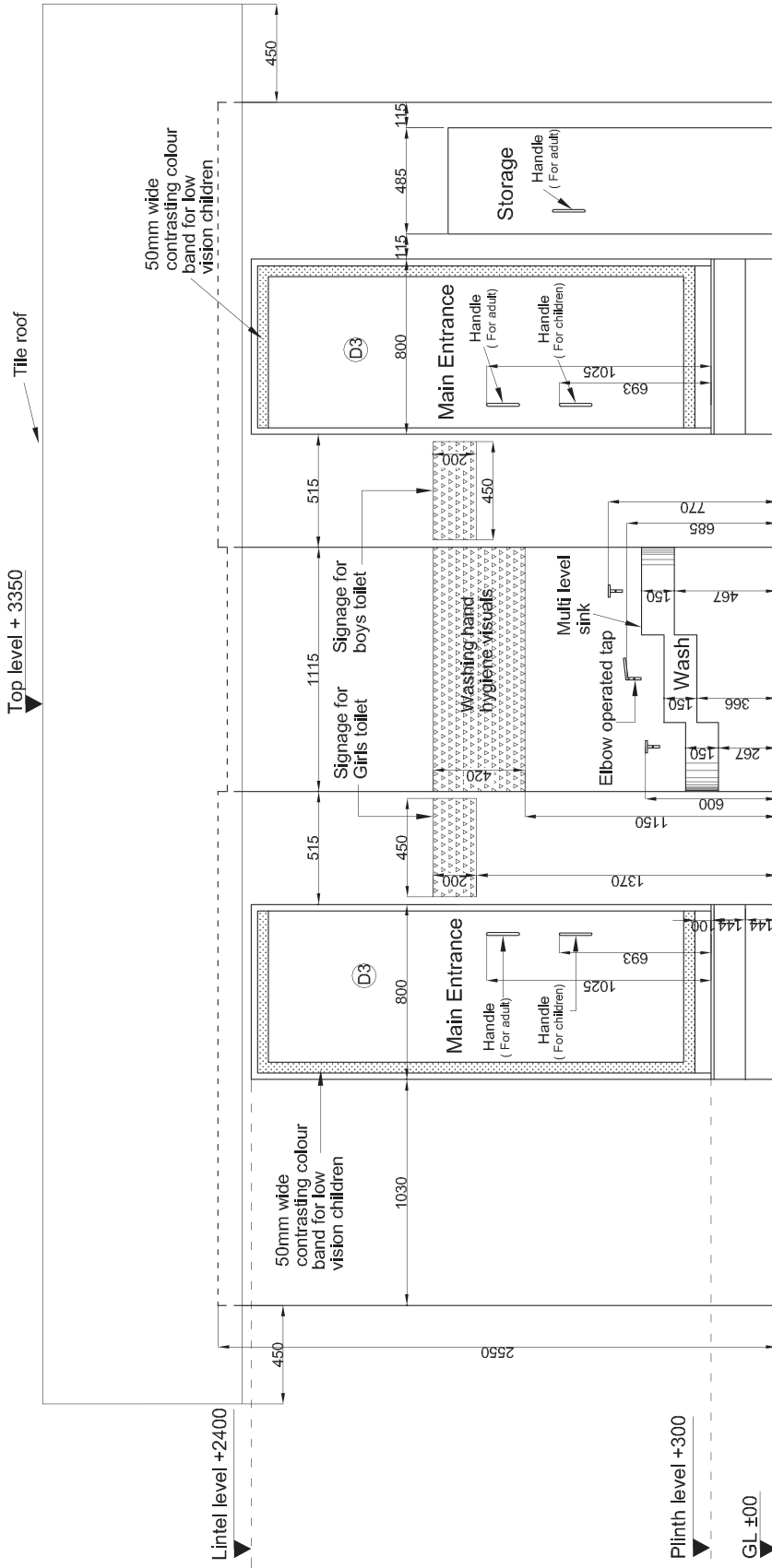

Girls Toilet Block

Boys Toilet Block

Front Elevation

09

Schedule of openings			
Name	Size w x h	Name Size w x h	
D3	800x2100	V1	600x450
D4	700x2100	V2	450x450
D5	600x1500		

Proposed Toilet Basic Core Design 40 G+ 40 B Linear

Elevation

Scale: 1:50

Dimensions are in mm

Bill of quantities – 09 BCD Linear 40G +40B

ITEM	UNIT	Quantity	Rate	Indexed rate	Amount
9	Tile work				
a	Ceramic tile work in floor	sq.m	4.0663	504.10	594.84
b	Ceramic tile work in dado	sq.m	12.09375	504.10	594.84
c	Antiskid tiles in Ramp	sq.m		406.15	479.26
10	Sanitary fixtures				
a	Rural squatting pan	number	2	350.00	413.00
b	Girl's squatting urinal	number	2	300.00	354.00
11	Plumbing				
a	GI pipe water supply line (internal) +3m external	rn.m	6.0714	78.65	92.81
b	Taps	number	7	250.00	295.00
c	Waste water pipe for flushing	rn.m	12.8229	31.05	36.64
12	Sewage				
a	Sewage line from squatting pan to first IC + 3m	rn.m	4.9093	111.60	131.69
b	Waste drain line from urinal to first IC + 3m	rn.m	5.4704	111.60	131.69
13	Roof work				
a	Roof area (sloping, with overhangs and overlaps)	sq.m	15.8868	700.00	700.00
14	Doors				
a	D1	number		500.00	590.00
b	D2	number		500.00	590.00
c	D3	number	2	500.00	590.00
d	D4	number	2	500.00	590.00
e	D5	number	2	500.00	590.00
f	Storage door shutter	number	1	500.00	590.00
15	Ventilators				
a	V1	number	1	350.00	413.00
b	V2	number	5	350.00	413.00
c	V3	number		350.00	413.00
d	V4	number		350.00	413.00
16	Incinerator				
a	Metal/ Masonry incinerator	number	1	1500.00	1500.00
17	Painting work				
a	Internal white washing	sq.m	40.8511	35.40	41.77
b	External wall painting	sq.m	31.8383	30.00	35.40
c	Door and ventilator	sq.m	19.083	58	68.44
18	Metal Work				
a	Grab bars in toilets 40mm dia MS pipe	rn.m		32.10	37.88
b	Rail in 40mm dia MS pipe in ramp	rn.m		32.10	37.88
c	Vertical rail supports 25mm dia MS bars	rn.m		32.10	37.88

Total Amount Rs. 73328
Total Area Sq.m 9.88
Cost per sqm 7422

ITEM	UNIT	Quantity	Rate	Indexed rate	Amount
1	Excavation				
a	Foundation	cu.m	6.1979	30.00	219.41
b	Leach and soak pit	cu.m	4.2076	30.00	148.95
c	Ramp work	cu.m		30.00	35.4
2	PCC				
a	1:3:6 PCC in foundation	cu.m	1.4780	1678.00	2926.46
b	1:4:8 PCC in flooring	cu.m	0.5303	1503.60	940.95
c	1:4:8 PCC in Ramp	cu.m		1503.60	1774.25
3	Back-filling				
a	Foundation	cu.m	1.7779	25.55	30.15
b	Sand fill under floor	cu.m	0.5098	95.60	57.51
c	Consolidated aggregate under floor	cu.m	0.5017		0.00
d	Infill in soak pit	cu.m	1.8997	25.55	30.15
e	Back fill in Ramp	cu.m		25.55	30.15
4	Brick work				
a	Brick work in foundation and plinth	cu.m	3.0631	1452.9	1714.42
b	Brickwork in Ramp	cu.m		1452.90	1714.42
c	Honey comb brickwork in leach pit	sq.m	6.0540	216.45	255.41
d	75mm thk masonry partition in superstructure	sq.m	1.9815	119.4	140.89
e	115mm thick masonry in superstructure	sq.m	46.6524	199.00	234.82
f	230mm thick masonry in superstructure	cu.m	0.4940	1690.45	1994.73
g	Brick work in steps	cu.m	0.5443	1690.45	1994.73
h	Dry brick work in paving	sq.m	2.0352	80.85	95.40
5	RCC work				
a	1:2:4 RCC Plinth band	cu.m	0.3684	5209.75	6147.51
b	1:2:4 RCC Lintel band (all types)	cu.m	0.2611	5209.75	6147.51
c	1:2:4 PCC bed blocks for roof anchorage	cu.m	0.0159	2136.35	2520.89
6	Slab (Stone / precast RCC)				
a	125mm thk Slab under water tank	sq.m	0.6467	570.79	673.53
b	75mm thk Slab under hand wash areas (all)	sq.m	0.8460	342.47	404.11
c	50mm thk Partition shelves in storage	sq.m	0.7020	228.31	269.41
d	75mm thk Cover for water tank	sq.m	0.6467	342.47	404.11
e	75mm thk Cover for leach pit	sq.m	1.5386	342.47	404.11
7	Pointing and plastering				
a	1:4 pointing in exposed brick work	sq.m	31.8383	29.75	35.11
b	1:6 cement sand plastering	sq.m	40.8511	39.90	47.08
c	1:6 cement sand with waterproof plastering	sq.m	3.0900	32.73	38.62
8	Flooring				
a	Cement concrete flooring	sq.m	4.2790	143.85	169.74

cu.m – Cubic meter, sq.m – Square meter, rn.m – Running meter

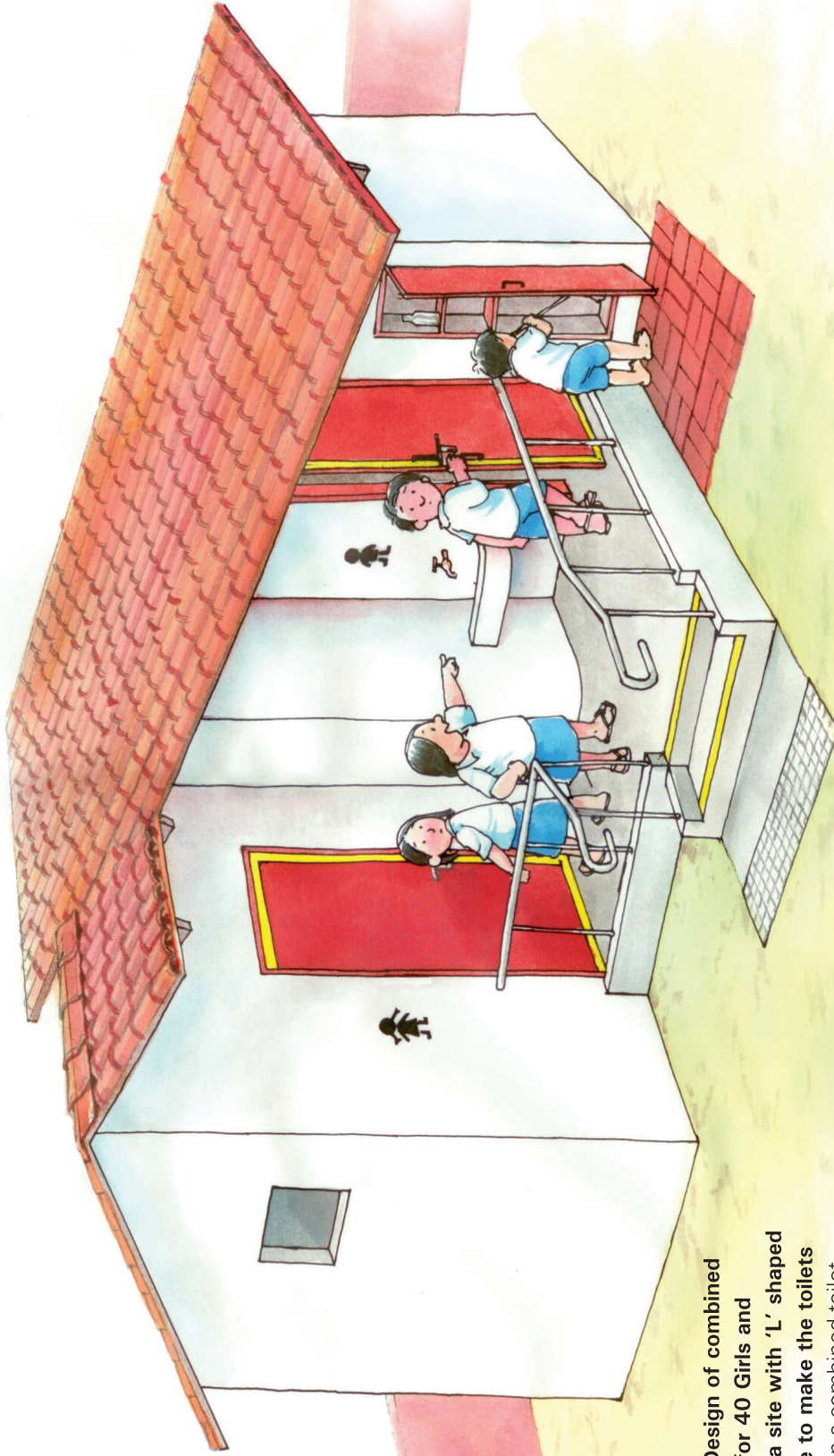

Basic Core Design of combined toilet block for 40 Girls and 40 Boys on a site with 'L' shaped corner space to make the toilets Suitable when a combined toilet block for Girls and Boys is needed and the space available is 'L' shaped in the corner.

Total Built-up Area: 9.58 sq.m
Indicative cost* Rs 79,342

Additional salient features:

The design has:

1. Segregated entrances for girl's and boy's toilet blocks.
2. One toilet for girls with internal wash
3. Two girl's urinals
4. One toilet for boys with internal wash
5. Two boy's urinals
6. No common wall between boys and girl's toilet area.

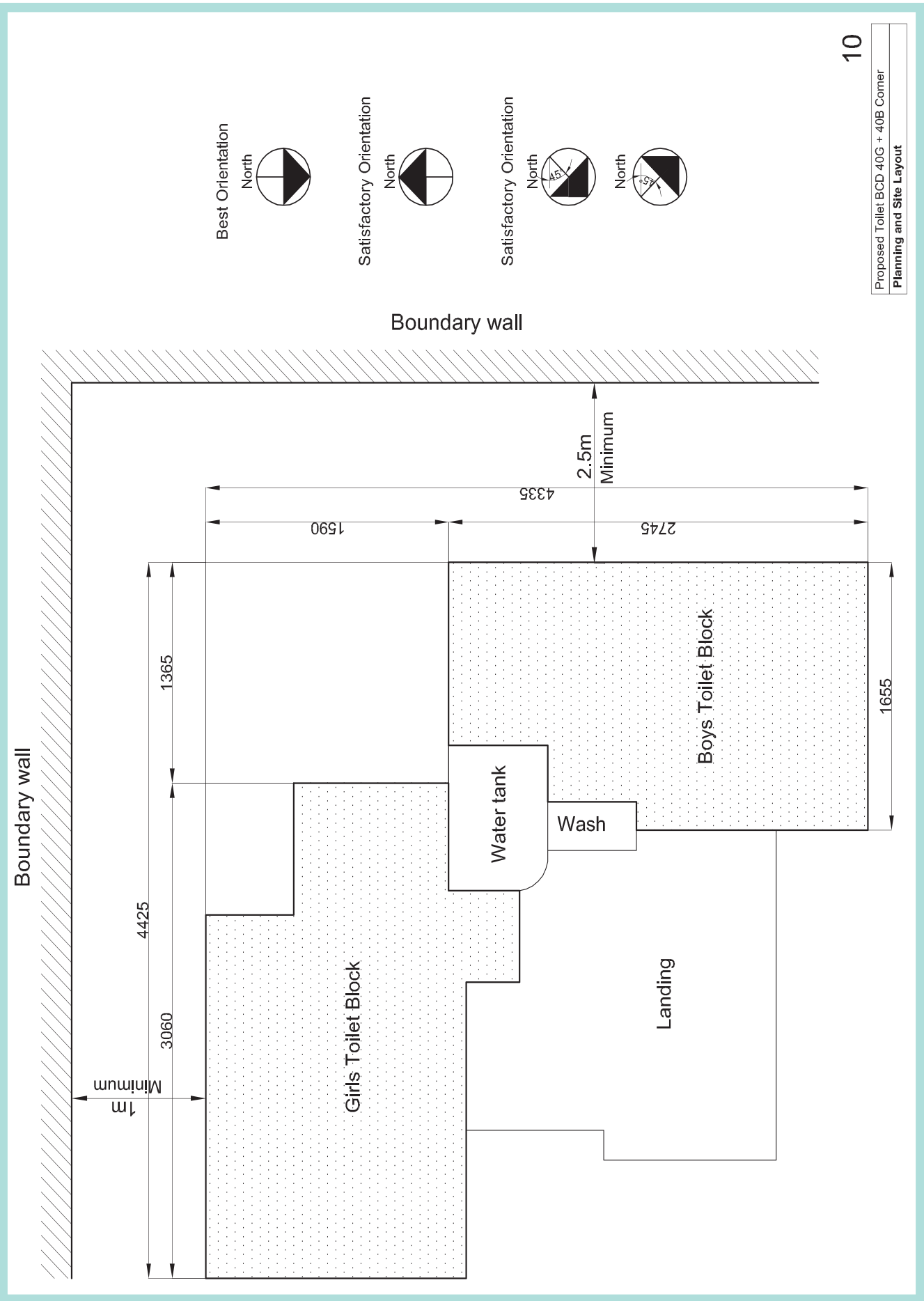

Plan – 10 BCD Corner 40G + 40B

Notes

- This design is valid for brick strength not below 35kg/sq.cm.
- Foundation design is only indicative & may need review based on local site conditions.
- For masonry water tank, the foundation shall be in 230mm brick up to the base of the tank.
- Mortar 1:4 for 115mm thick masonry. No reinforcement bars in alternate courses.
- This design is valid for earth quake zone I, II & III only
- No water supply or waste water carrying pipe shall be concealed in the masonry wall. It shall be exposed and fixed with clips and not chased in masonry walls.
- In case the masonry specification is changed from that given here, maintain the internal clear dimensions & the layout and provide suitable redesigned foundation.
- Stopping roof overhang and its anchorage design may need review in cyclone prone regions.
- In case roof specifications are changed from that given here (e.g. flat roof in stone or RCC) provide suitable strengthening of masonry while maintaining all internal clearances in the layout design.
- Only one metallic / masonry in chertator to be put along the location indicated as ICN.
- In chertator to be provided only with Girls toilet and to have chute from inside.
- Location of leach pits, soak pits, waste drainage pipes & inspection chamber is indicative only. Actual location to be decided based on site conditions.
- Minimum distance of leaching pit from building foundation to be 125cm in different soil types.
- Design of leach pit shown is for 40+40=80 children with its volume sufficient for catering approximately one year in different soil types. For higher capacity or longer duration, design will need review.

Key to symbols:

- Pipe carrying waste water from wash area to flush urinals.
- - - Open / Covered drain for waste from Urinal / Squatting pan.
- ▨ Masonry wall.
- Roof line

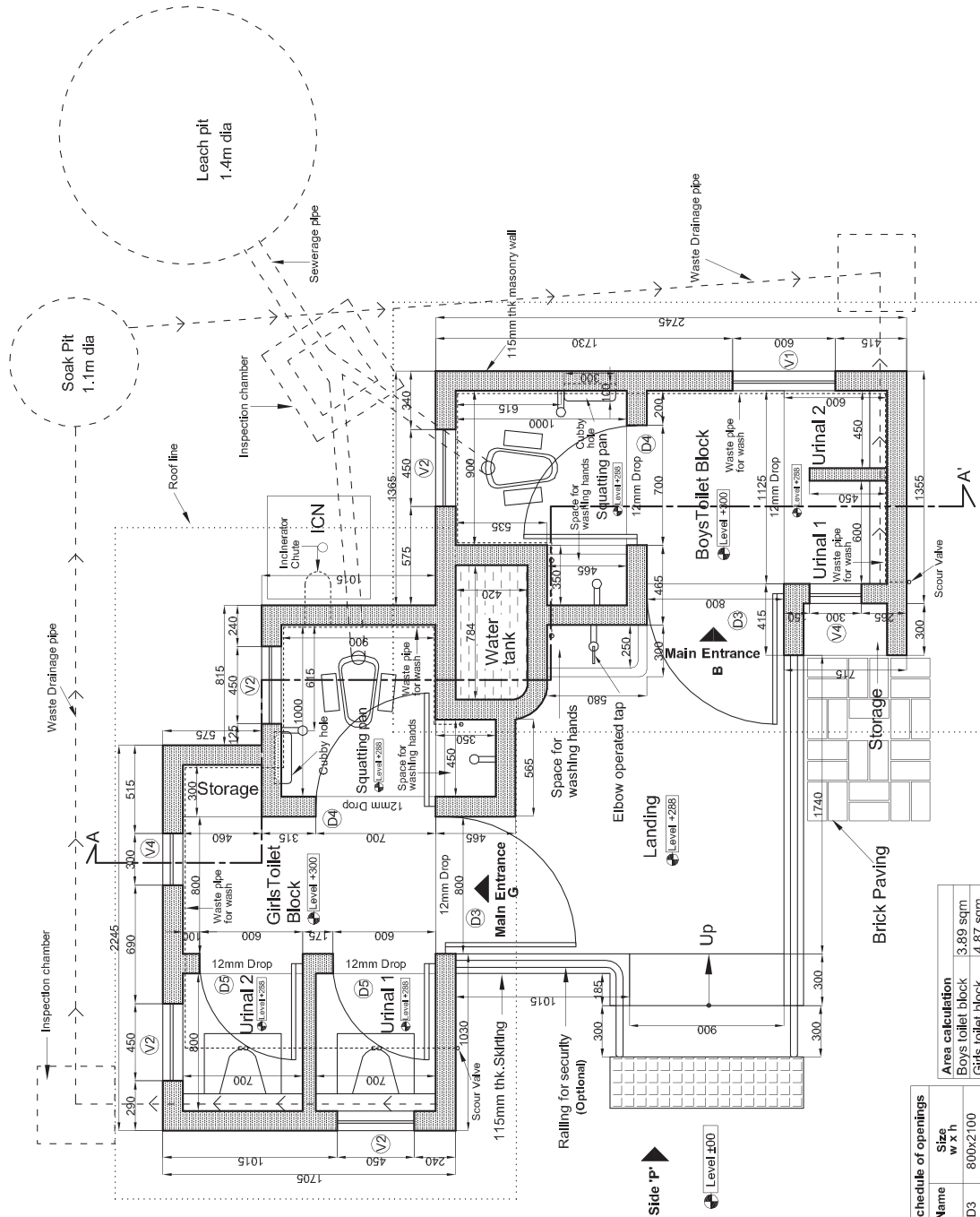

Schedule of openings	
Name	Size w x h
D3	800x2100
D4	700x2100
D5	600x1500
V1	450x450
V4	300x450

Area calculation	
Boys toilet block	3.89 sqm
Girls toilet block	4.87 sqm
Water tank	0.65 sqm
Wash area	0.174 sqm
Landing+Stairs	3.65 sqm
Total Overall Area	13.23 sqm
Total Covered Area	9.58 sqm

Plan

Proposed Toilet Basic Core Design 40G + 40B Corner

Scale: 1:100

All dimensions are in mm.

10

Section & Details – 10 BCD Corner 40G+40B

Suggested brief specifications:

- Civil work**
1. Pre-construction chemical termite treatment as per need.
 2. PCC 1:3:6 Cement: Coarse Sand: Coarse Aggregate in foundation.
 3. Foundation and Plinth in 1:4 cement mortar in brickwork.
 4. 75mm thick plinth band in 1:2:4 Reinforced Cement Concrete.
 5. Superstructure masonry in 1:4 cement mortar in 115 mm thick brick work.
 6. Pointing in 1:4 on exterior face.
 7. Plastering in 1:6 on interior face above dado level
 8. All urinals and squatting pan area with ceramic tile floor and dado up to 750mm from finished floor.
 9. Use of waterproofing compound for plaster upto dado level and for fixing tile.
 10. All other flooring in cement concrete / stone tile as per availability. Slope in toilets & urinals floor is 1:50.
 11. 150mm thick lintel band in 1:2:4 Reinforced Cement Concrete.
 12. Built-in water tank with masonry walls and lining of waterproof cement plaster.
 13. Sloping roof in MCR / Country tile / Mangalore tile with metal / timber under-structure.
 14. Roof under-structure to be tied to masonry/plinth band as per detail given.
 15. Door and ventilator frame in metal angle sections, painted with two coats of primer before installation.
 16. Door shutter in PVC/metal painted with two coats of primer and painted with enamel paint in light colour.
- Plumbing and Sanitary work**
17. All plumbing pipes in B class GI pipes with suitable elbow / tee / nipple / union / scour valves.
 18. All taps of best quality, locally available.
 19. All waste water carrying pipes in HDPE / PVC to flush urinals.
 20. All girls urinals squatting type in glazed ceramic type, white in colour.
 21. All squatting pan of rural pan type in glazed ceramic type, white in colour
 22. All drainage and sewage pipes from Urinals / Squatting pan area in HDPE / PVC / CI / SW as per local availability.
 23. Leach pit with 115mm thick honeycomb brickwork in 1:4 cement sand mortar

10

Proposed Toilet BCD 40G + 40B Corner

Section and Details

Scale

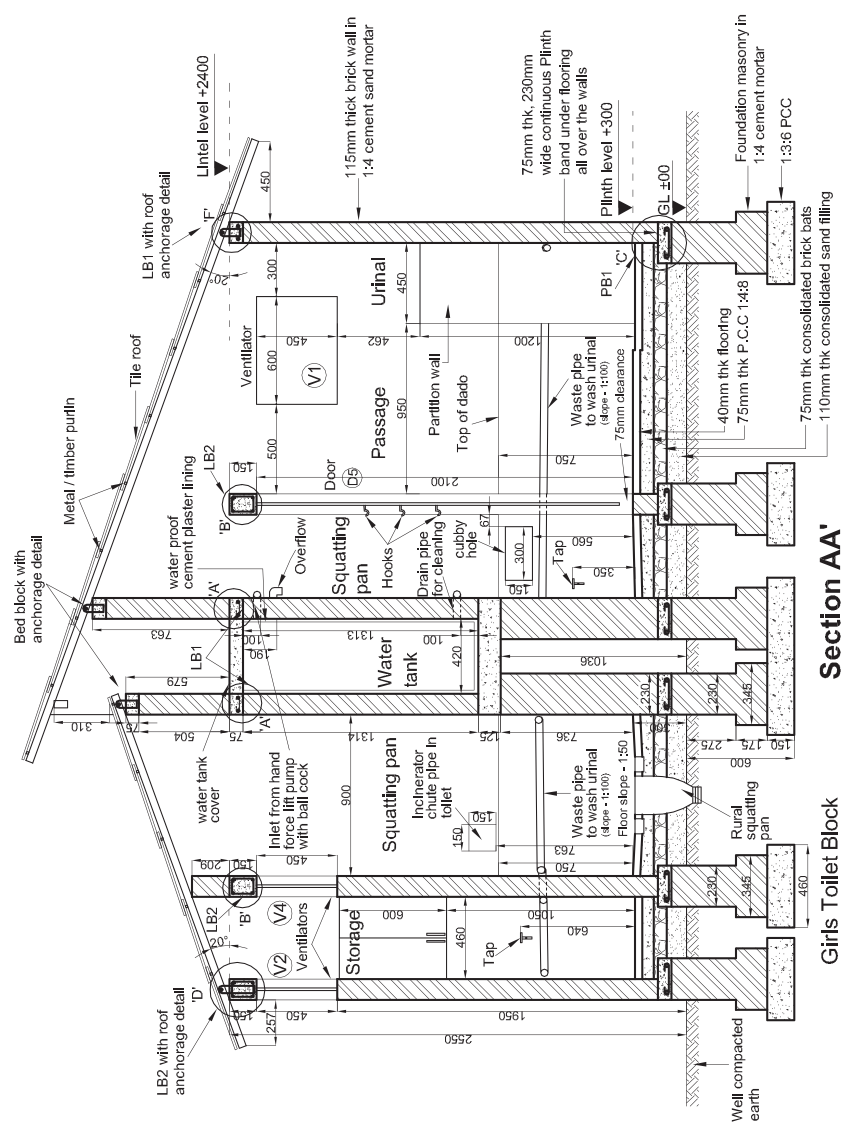
 All dimensions are in mm

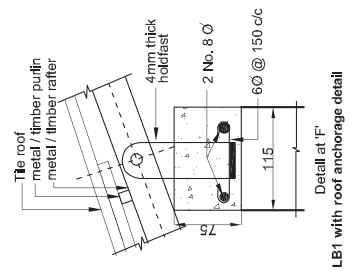

Boys Toilet Block

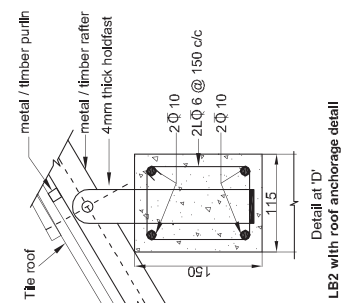

Section AA'



Girls Toilet Block

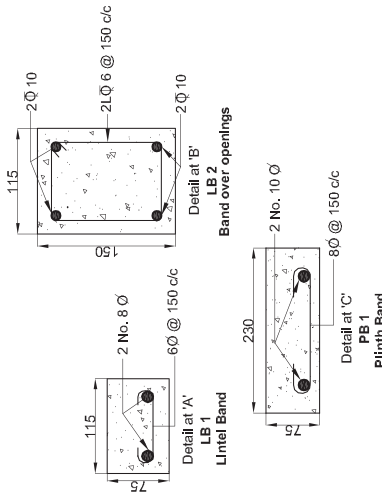

Schedule of openings

Name	Size W x H
D3	800x2100
D4	700x2100
D5	600x1500
V1	600x450
V2	450x450
V4	300x450

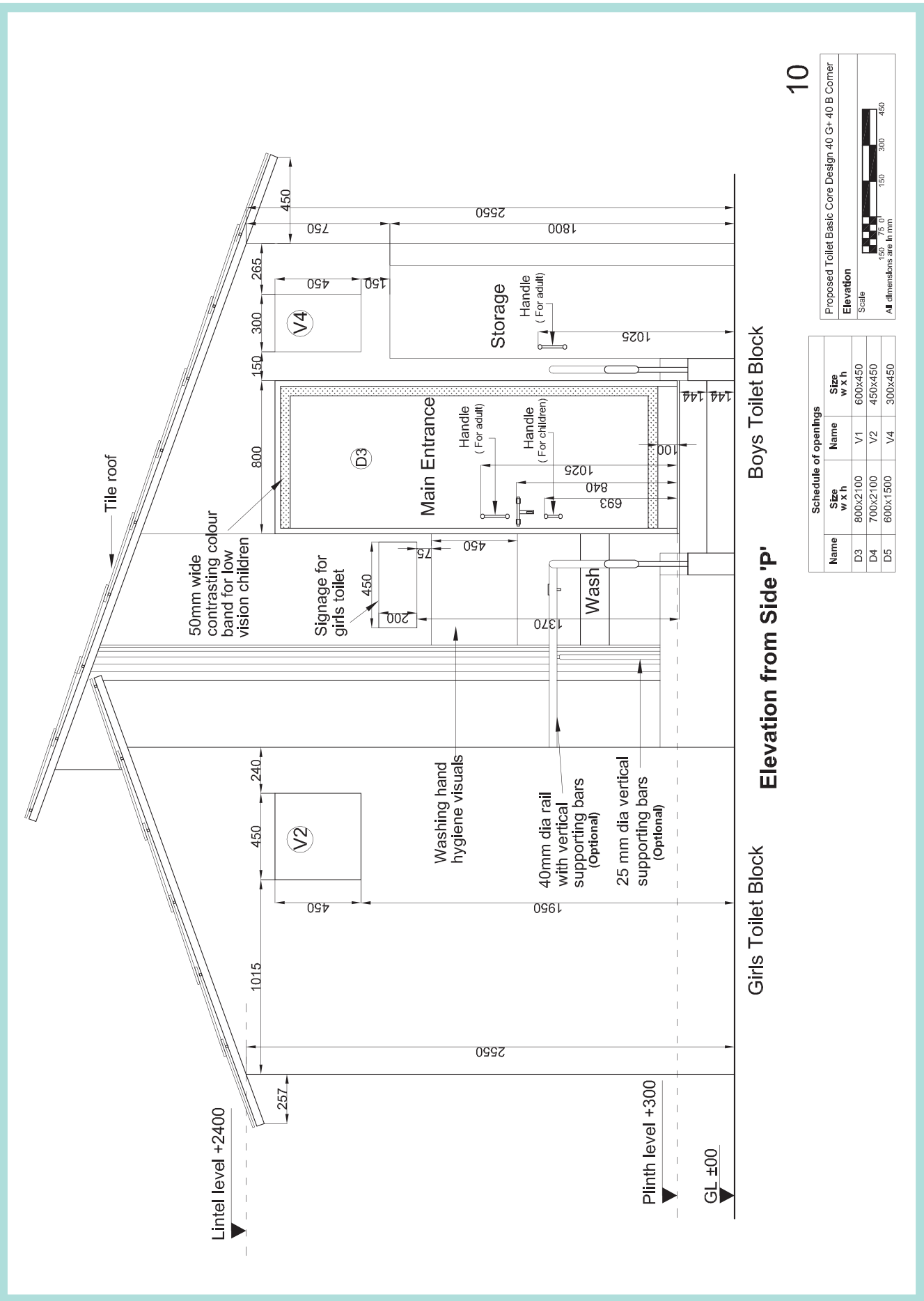

10

Elevation from Side 'P'

Schedule of openings			
Name	Size w x h	Name	Size w x h
D3	800x2100	V1	600x450
D4	700x2100	V2	450x450
D5	600x1500	V4	300x450

Proposed Toilet Basic Core Design 40 G+ 40 B Corner	
Elevation	
Scale	1:50
All dimensions are in mm	

Bill of quantities – 10 BCD Corner 40G +40B

ITEM	UNIT	Quantity	Rate	Indexed rate	Amount
1 Excavation					
a Foundation	cu.m	6.9758	30.00	35.4	246.94
b Leach and soak pit	cu.m	4.2076	30.00	35.4	148.95
c Ramp work	cu.m		30.00	35.4	
2 PCC					
a 1:3:6 PCC in foundation	cu.m	1.6356	1678.00	1980.04	3238.51
b 1:4:8 PCC in flooring	cu.m	0.8876	1503.60	1774.25	1574.91
c 1:4:8 PCC in Ramp	cu.m		1503.60	1774.25	
3 Back-filling					
a Foundation	cu.m	1.9674	25.55	30.15	59.32
b Sand fill under floor	cu.m	0.4563	95.60	112.81	51.47
c Consolidated aggregate under floor	cu.m	0.4541		0.00	0.00
d Infill in soak pit	cu.m	1.8997	25.55	30.15	57.27
e Back fill in Ramp	cu.m		25.55	30.15	
4 Brick work					
a Brickwork in foundation and plinth	cu.m	3.3897	1452.9	1714.42	5811.33
b Brickwork in Ramp	cu.m		1452.90	1714.42	
c Honey comb brickwork in leach pit	sq.m	6.0540	216.45	255.41	1546.26
d 75mm thk masonry partition in superstructure	sq.m	1.9815	119.4	140.89	279.18
e 115mm thick masonry in superstructure	sq.m	50.3497	199.00	234.82	11823.12
f 230mm thick masonry in superstructure	cu.m	0.4816	1690.45	1994.73	960.66
g Brick work in steps	cu.m	1.0195	1690.45	1994.73	2033.63
h Dry brick work in paving	sq.m	0.7111	80.85	95.40	67.84
5 RCC work					
a 1:2:4 RCC Plinth band	cu.m	0.4077	5209.75	6147.51	2506.39
b 1:2:4 RCC Lintel band (all types)	cu.m	0.2834	5209.75	6147.51	1742.20
c 1:2:4 PCC bed blocks for roof anchorage	cu.m	0.0278	2136.35	2520.89	70.01
6 Slab (Stone / precast RCC)					
a 125mm thk Slab under water tank	sq.m	0.6589	570.79	673.53	443.79
b 75mm thk Slab under hand wash areas (all)	sq.m	0.6665	342.47	404.11	269.34
c 50mm thk Partition shelves in storage	sq.m	0.6143	228.31	269.41	165.48
d 75mm thk Cover for water tank	sq.m	0.6589	342.47	404.11	266.27
e 75mm thk Cover for leach pit	sq.m	1.5386	342.47	404.11	621.77
7 Pointing and plastering					
a 1:4 pointing in exposed brick work	sq.m	41.8688	29.75	35.11	1469.80
b 1:6 cement sand plastering	sq.m	46.1196	39.90	47.08	2171.40
c 1:6 cement sand with waterproof plastering	sq.m	1.9613	32.73	38.62	75.75
8 Flooring					
a Cement concrete flooring	sq.m	5.9763	143.85	169.74	1014.44

cu.m – Cubic meter, sq.m – Square meter, m.m – Running meter

ITEM	UNIT	Quantity	Rate	Indexed rate	Amount
9 Tile work					
a Ceramic tile work in floor	sq.m	3.8816	504.10	594.84	2308.92
b Ceramic tile work in dado	sq.m	11.71875	504.10	594.84	6970.76
c Antiskid tiles in Ramp	sq.m		406.15	479.26	
10 Sanitary fixtures					
a Rural squatting pan	number	2	350.00	413.00	826.00
b Girl's squatting urinal	number	2	300.00	354.00	708.00
11 Plumbing					
a GI pipe water supply line (internal) +3m external	m.m	7.3826	78.65	92.81	685.16
b Taps	number	5	250.00	295.00	1475.00
c Waste water pipe for flushing	m.m	12.4378	31.05	36.64	455.71
12 Sewage					
a Sewage line from squatting pan to first IC + 3m	m.m	5.743	111.60	131.69	756.28
b Waste drain line from urinal to first IC + 3m	m.m	4.5348	111.60	131.69	597.18
13 Roof work					
a Roof area (sloping, with overhangs and overlaps)	sq.m	17.4067	700.00	700.00	12184.69
14 Doors					
a D1	number		500.00	590.00	
b D2	number		500.00	590.00	
c D3	number	2	500.00	590.00	1180.00
d D4	number	2	500.00	590.00	1180.00
e D5	number	2	500.00	590.00	1180.00
f Storage door shutter	number	1	500.00	590.00	590.00
15 Ventilators					
a V1	number	1	350.00	413.00	413.00
b V2	number	4	350.00	413.00	1652.00
c V3	number		350.00	413.00	
d V4	number	2	350.00	413.00	826.00
16 Incinerator					
a Metal / Masonry incinerator	number	1	1500.00	1500.00	1500.00
17 Painting work					
a Internal white washing	sq.m	46.1196	35.40	41.77	1926.51
b External wall painting	sq.m	41.8688	30.00	35.40	1482.16
c Door and ventilator	sq.m	19.1505	58	68.44	1310.66
18 Metal Work					
a Grab bars in toilets 40mm dia MS pipe	m.m		32.10	37.88	
b Rail in 40mm dia MS pipe in ramp	m.m	5.318	32.10	37.88	201.44
c Vertical rail supports 25mm dia MS bars	m.m	5.705	32.10	37.88	216.09

Total Amount Rs. 79342
Total Area Sq.m 9.58
Cost per sqm 8282



Basic Core Design of combined toilet block for 80 Girls and 80 Boys on a site with Linear space to make the toilets

Suitable when a combined toilet block for Girls and Boys is needed and the space available is elongated in shape.

Total Built-up Area: 12.45 sq.m

Indicative cost Rs 94,902

Additional salient features:

The design has:

1. Segregated entrances for girl's and boy's toilet blocks.

2. One toilet for girls with internal wash
3. Four girl's urinals
4. One toilet for boys with internal wash
5. Four boy's urinals
6. One thick partition wall between boys and girl's toilet area.
7. One common external wash with provision for storage water tank.

ORIENTATION

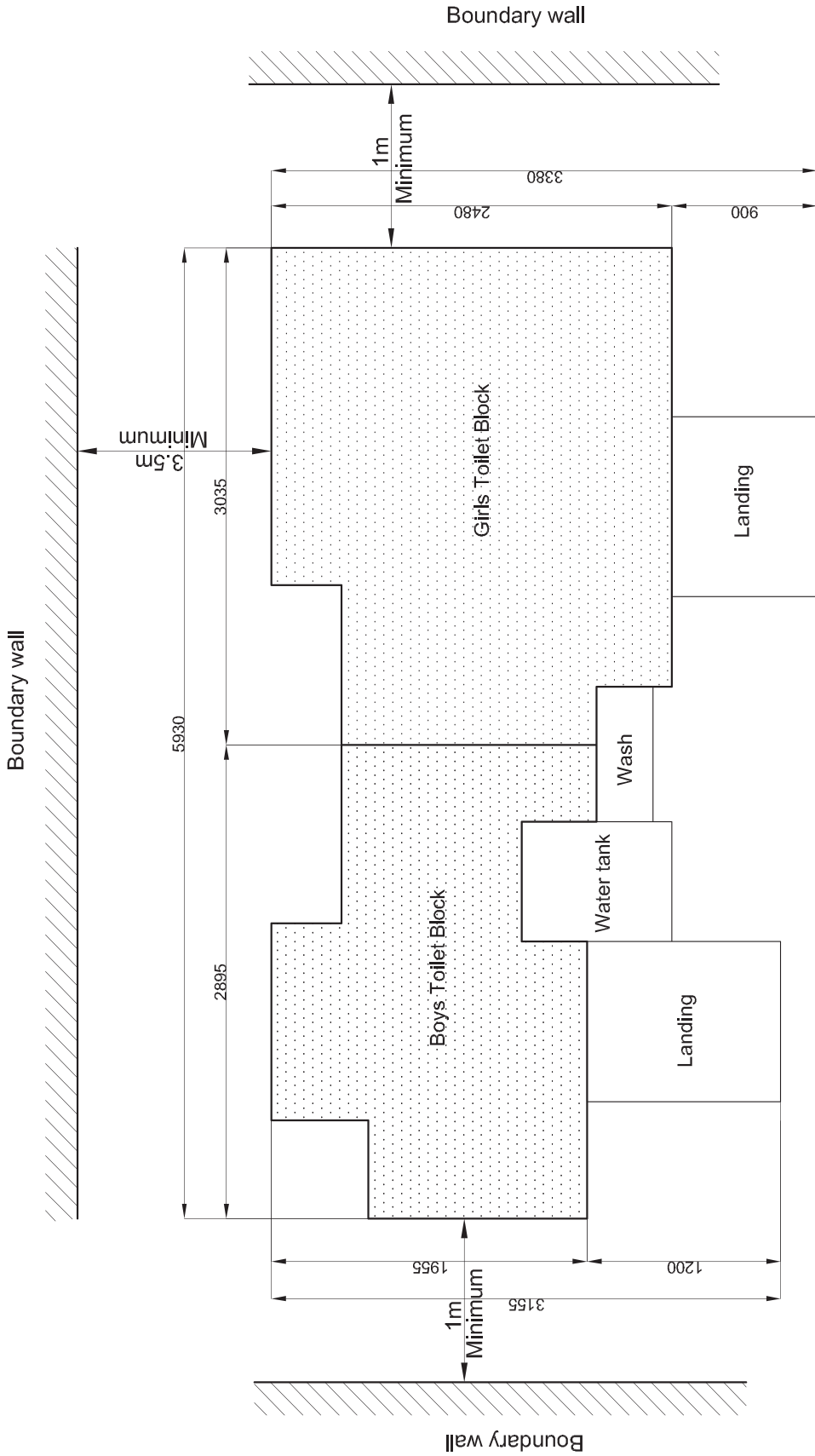

Best Orientation



Satisfactory Orientation



Acceptable Orientation



Notes

1. This design is valid for brick strength not below 38kg/sq.cm.
2. Foundation design is only indicative & may need review based on local site conditions.
3. For masonry water tank, the foundation shall be in 230mm brick up to the base of the tank.
4. Mortar 1:4 for 115mm thick masonry. No reinforcement bars in alternate courses.
5. This design is valid for earth quake zone I, II and III only
6. No water supply or waste water carrying pipe shall be concealed in the masonry wall. It shall be exposed and fixed with clips and not chased in masonry walls.
7. In case the masonry specification is changed from that given here, maintain the internal clear dimensions & the layout and provide suitable redesigned foundation.
8. Sloping roof overhang and its anchorage design may need review in cyclone prone regions.
9. In case roof specifications are changed from that given here (e.g. flat roof in stone or RCC) provide suitable strengthening of masonry while maintaining all internal clearances in the layout design.
10. Only one metallic / masonry InCherator to be put along the location indicated as ICN.
11. InCherator to be provided only with GFI's toilet and to have chute from inside.
12. Location of leach pits, soak pits, waste drainage pipes & inspection chamber is indicative only. Actual location to be decided based on site conditions.
13. Minimum distance of leaching pit from building foundation to be 125cm in different soil types.
14. Design of leach pit shown is for 80+80=160 children with its volume sufficient for catching approximately six months in different soil types. For higher capacity or longer duration, design will need review.

Key to symbols:

1. Pipe carrying waste water from wash area to flush urinals.
2. Open / Covered drain for waste from Urinal / Squatting pan.
3. Masonry wall.
4. Roof line

Schedule of openings	
Name	Size W x H
D3	800x2100
D4	700x2100
D5	600x1500
V1	600x450
V2	450x450
V4	300x450

Area calculation (Core)	
Boys toilet block	4.56 sqm
Girls toilet block	6.93 sqm
Water tank	0.67 sqm
Wash area	0.29 sqm
Landing+Steps	2.17 sqm
Total Overall Area	14.62 sqm
Total Covered Area	12.45 sqm

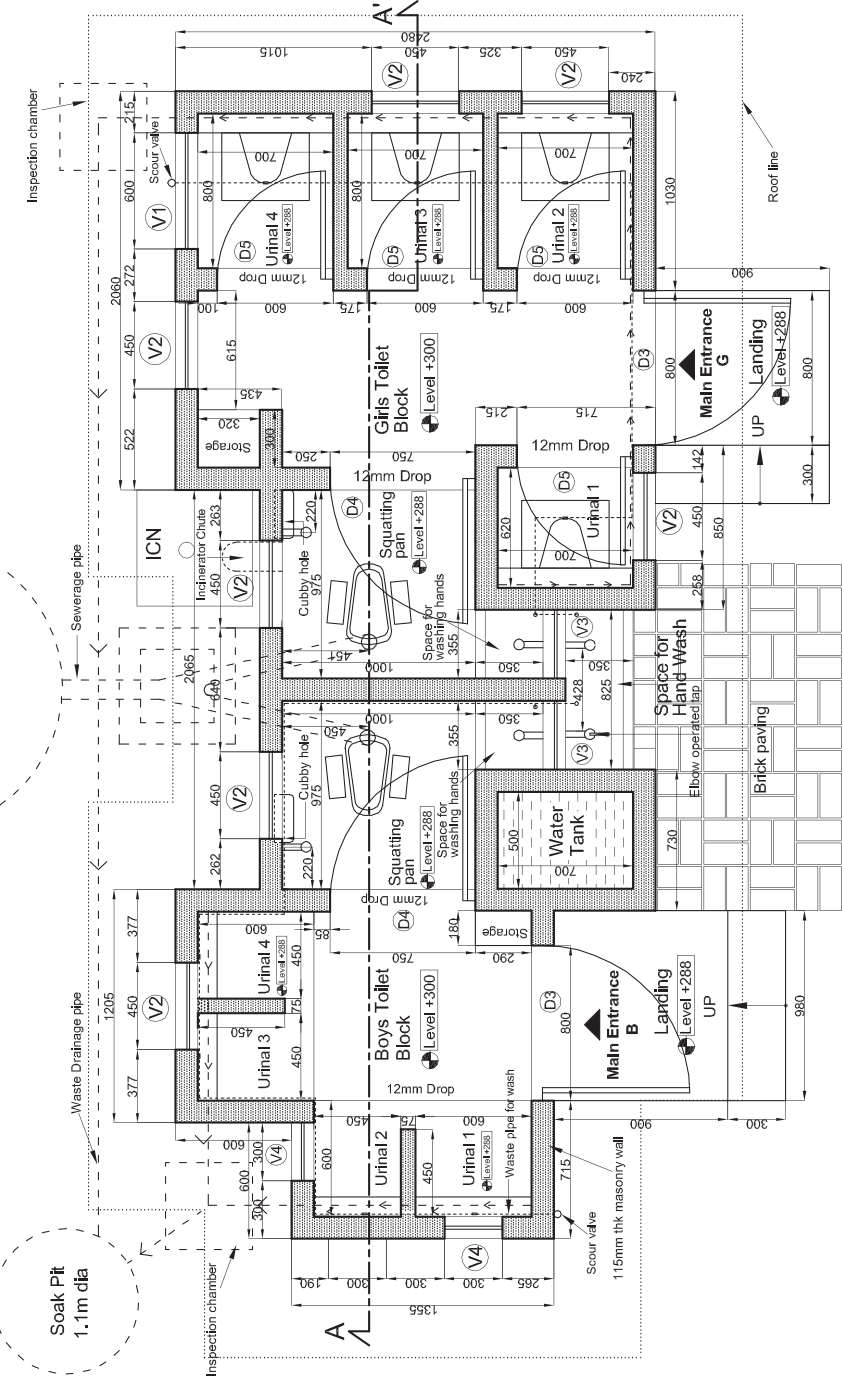
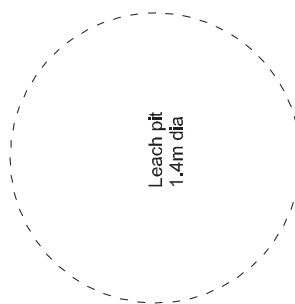

Front side
Plan

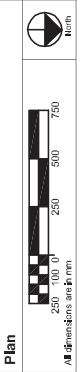

Section & Details – 11 BCD linear 80G+80B

Schedule of openings	
Name	Size w x h
D3	800x2100
D4	700x2100
D5	600x1500
V1	600x450
V2	450x450
V4	300x450

Suggested brief specifications:

- Civil work**
1. Pre-construction chemical termite treatment as per need.
 2. PCC 1:3:6 Cement Coarse Sand; Coarse Aggregate in foundation.
 3. Foundation and Plinth in 1:4 cement mortar in brickwork.
 4. 7.5mm thick plinth band in 1:2:4 Reinforced Cement Concrete.
 5. Superstructure masonry in 1:4 cement mortar in 115 mm thick brick work.
 6. Pointing in 1:4 on exterior face.
 7. Plastering in 1:6 on interior face above dado level.
 8. All urinals and squatting pan area with ceramic tile floor and dado up to 750mm from finished floor.
 9. Use of waterproofing compound for plaster upto dado level and for fixing tile.
 10. All other flooring in cement concrete / stone tile as per availability. Slope in toilets & urinals floor is 1:50 or more.
 11. 150mm thick Lintel band in 1:2:4 Reinforced Cement Concrete.
 12. Built-in water tank with masonry walls and lining of waterproof cement plaster.
 13. Sloping roof in MCR / Country tile / Mangalore tile with metal / timber under-structure.
 14. Roof under-structure to be tied to masonry/plinth band as per detail given.
 15. Door and ventilator frame in metal angle sections, painted with two coats of primer before installation.
 16. Door shutter in PVC/metal painted with two coats of primer and painted with enamel paint in light colour.
- Plumbing and Sanitary work**
17. All plumbing pipes in B class GI pipes with suitable elbow / tee / nipple / union / scour valves.
 18. All taps of best quality, locally available.
 19. All waste water carrying pipes in HDPE / PVC to flush urinals.
 20. All girls urinals squatting type in glazed ceramic type, white in colour.
 21. All squatting pan of rural pan type in glazed ceramic type, white in colour.
 22. All drainage and sewage pipes from Urinals / Squatting pan area in HDPE / PVC / CI / SW as per local availability.
 23. Leach pit with 115mm thick honeycomb brickwork in 1:4 cement sand mortar.

11

Proposed Toilet Basic Core Design 80 G+ 80 B Linear

Section and Details

Scale



All dimensions are in mm

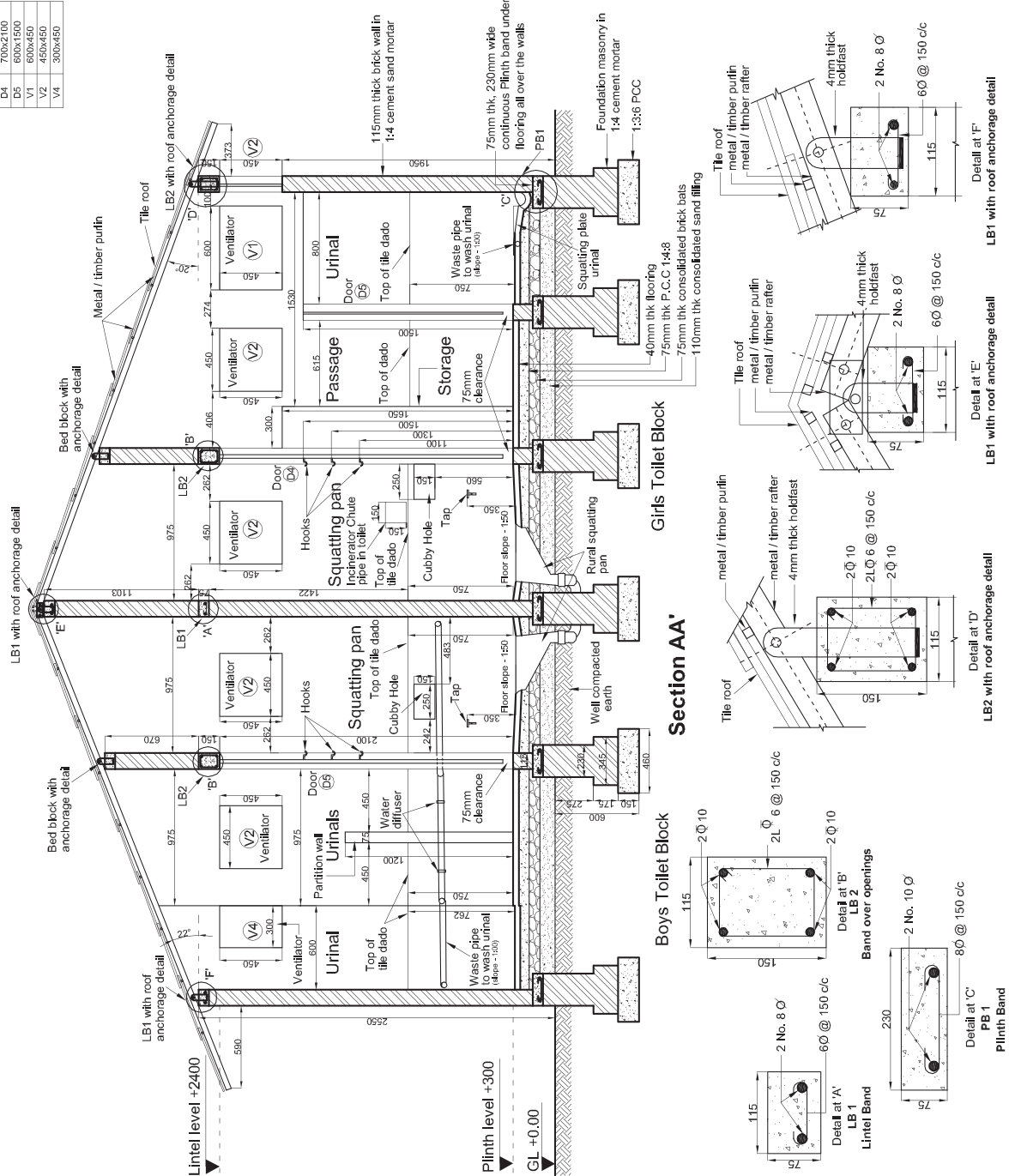

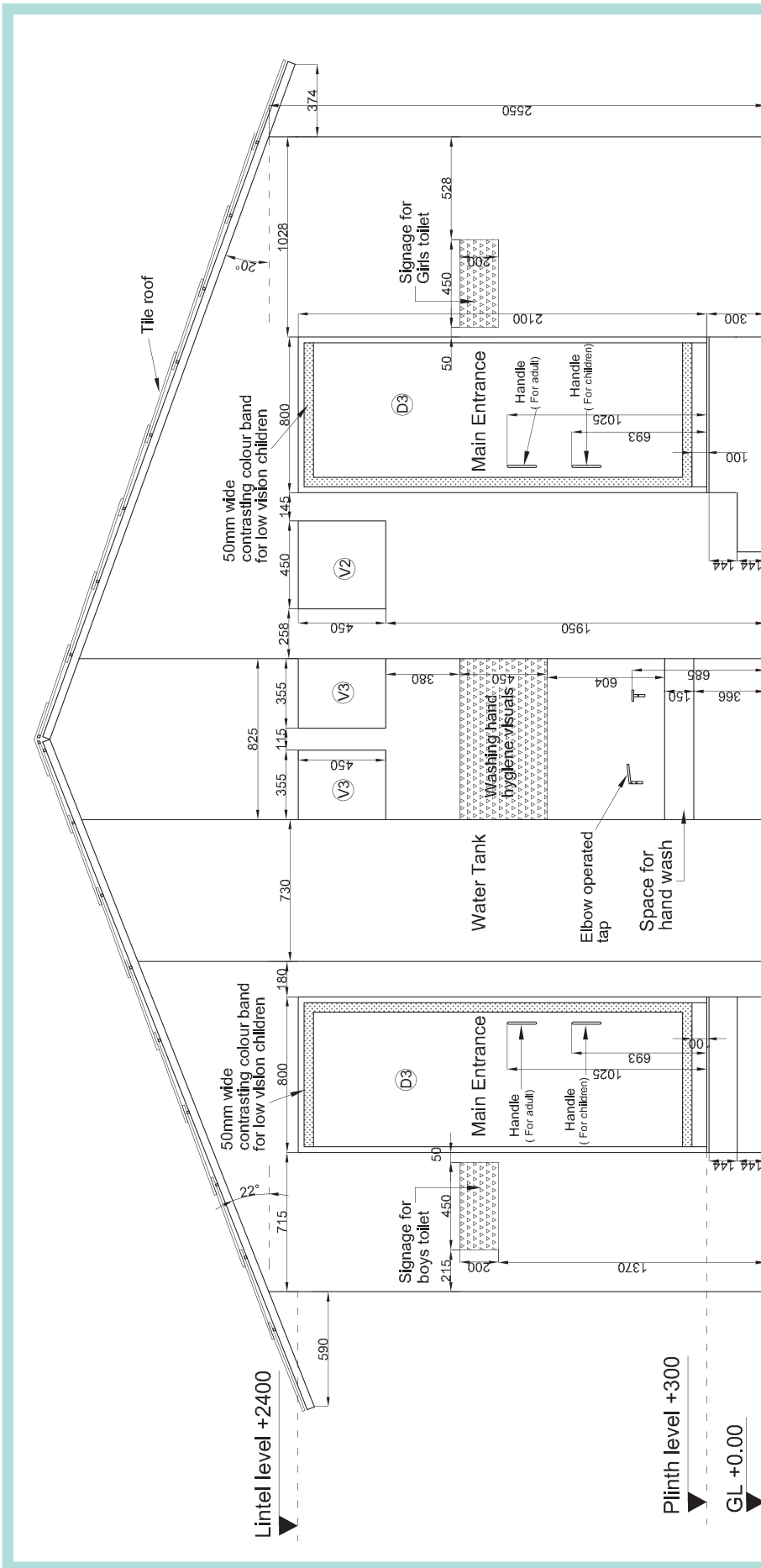

Boys Toilet Block

Front Elevation

Girls Toilet Block

11

Schedule of openings			
Name	Size w x h	Name	Size w x h
D3	800x2100	V1	600x450
D4	700x2100	V2	450x450
D5	600x1500	V4	300x450

Proposed Toilet Basic Core Design 80 G+ 80 B Linear

Elevation

Scale



All dimensions are in mm

Bill of quantities – 11 BCD linear 80G +80B

ITEM	UNIT	Quantity	Rate	Indexed rate	Amount
1 Excavation					
a Foundation	cu.m	7.9343	30.00	35.4	280.87
b Leach and soak pit	cu.m	4.2076	30.00	35.4	148.95
c Ramp work	cu.m		30.00	35.4	
2 PCC					
a 1:3:6 PCC in foundation	cu.m	1.9140	1678.00	1980.04	3789.85
b 1:4:8 PCC in flooring	cu.m	0.9325	1503.60	1774.25	1654.52
c 1:4:8 PCC in Ramp	cu.m		1503.60	1774.25	
3 Back-filling					
a Foundation	cu.m	2.3024	25.55	30.15	69.41
b Sand fill under floor	cu.m	0.6843	95.60	112.81	77.20
c Consolidated aggregate under floor	cu.m	0.6544		0.00	0.00
d Infill in soak pit	cu.m	1.8997	25.55	30.15	57.27
e Back fill in Ramp	cu.m		25.55	30.15	
4 Brick work					
a Brickwork in foundation and plinth	cu.m	3.9667	1452.9	1714.42	6800.68
b Brickwork in Ramp	cu.m		1452.90	1714.42	
c Honey comb brickwork in leach pit	sq.m	6.0540	216.45	255.41	1546.26
d 75mm thk masonry partition in superstructure	sq.m	4.2675	119.4	140.89	601.26
e 115mm thick masonry in superstructure	sq.m	54.1688	199.00	234.82	12719.92
f 230mm thick masonry in superstructure	cu.m	0.4800	1690.45	1994.73	957.47
g Brick work in steps	cu.m	0.5460	1690.45	1994.73	1089.12
h Dry brick work in paving	sq.m	1.8192	80.85	95.40	173.56
5 RCC work					
a 1:2:4 RCC Plinth band	cu.m	0.4771	5209.75	6147.51	2933.09
b 1:2:4 RCC Lintel band (all types)	cu.m	0.3562	5209.75	6147.51	2189.74
c 1:2:4 PCC bed blocks for roof anchorage	cu.m	0.0278	2136.35	2520.89	70.01
6 Slab (Stone / precast RCC)					
a 125mm thk Slab under water tank	sq.m	0.6789	570.79	673.53	457.26
b 75mm thk Slab under hand wash areas (all)	sq.m	0.7340	342.47	404.11	296.62
c 50mm thk Partition shelves in storage	sq.m	0.6756	228.31	269.41	182.01
d 75mm thk Cover for water tank	sq.m	0.6789	342.47	404.11	274.35
e 75mm thk Cover for leach pit	sq.m	1.5386	342.47	404.11	621.77
7 Pointing and plastering					
a 1:4 pointing in exposed brick work	sq.m	40.1819	29.75	35.11	1410.59
b 1:6 cement sand plastering	sq.m	50.9205	39.90	47.08	2397.44
c 1:6 cement sand with waterproof plastering	sq.m	1.8713	32.73	38.62	72.27
8 Flooring					
a Cement concrete flooring	sq.m	5.1153	143.85	169.74	868.29

cu.m – Cubic meter, sq.m – Square meter, m.m – Running meter

ITEM	UNIT	Quantity	Rate	Indexed rate	Amount
9 Tile work					
a Ceramic tile work in floor	sq.m	5.5048	504.10	594.84	3274.46
b Ceramic tile work in dado	sq.m	17.58	504.10	594.84	10457.25
c Antiskid tiles in Ramp	sq.m		406.15	479.26	
10 Sanitary fixtures					
a Rural squatting pan	number	2	350.00	413.00	826.00
b Girl's squatting urinal	number	4	300.00	354.00	1416.00
11 Plumbing					
a GI pipe water supply line (internal) +3m external	m.m	7.5824	78.65	92.81	703.70
b Taps	number	6	250.00	295.00	1770.00
c Waste water pipe for flushing	m.m	12.1524	31.05	36.64	445.25
12 Sewage					
a Sewage line from squatting pan to first IC + 3m	m.m	5.2037	111.60	131.69	685.26
b Waste drain line from urinal to first IC + 3m	m.m	4.601	111.60	131.69	605.90
13 Roof work					
a Roof area (sloping, with overhangs and overlaps)	sq.m	24.2287	700.00	700.00	16960.09
14 Doors					
a D1	number		500.00	590.00	
b D2	number		500.00	590.00	
c D3	number	2	500.00	590.00	1180.00
d D4	number	2	500.00	590.00	1180.00
e D5	number	4	500.00	590.00	2360.00
f Storage door shutter	number		500.00	590.00	0.00
15 Ventilators					
a V1	number	1	350.00	413.00	413.00
b V2	number	7	350.00	413.00	2891.00
c V3	number	2	350.00	413.00	826.00
d V4	number	2	350.00	413.00	826.00
16 Incinerator					
a Metal / Masonry incinerator	number	1	1500.00	1500.00	1500.00
17 Painting work					
a Internal white washing	sq.m	50.9205	35.40	41.77	2127.05
b External wall painting	sq.m	40.1819	30.00	35.40	1422.44
c Door and ventilator	sq.m	18.897	58	68.44	1293.31
18 Metal Work					
a Grab bars in toilets 40mm dia MS pipe	m.m		32.10	37.88	
b Rail in 40mm dia MS pipe in ramp	m.m		32.10	37.88	
c Vertical rail supports 25mm dia MS bars	m.m		32.10	37.88	

Total Amount Rs. 94902
Total Area Sq.m 12.45
Cost per sqm 7623

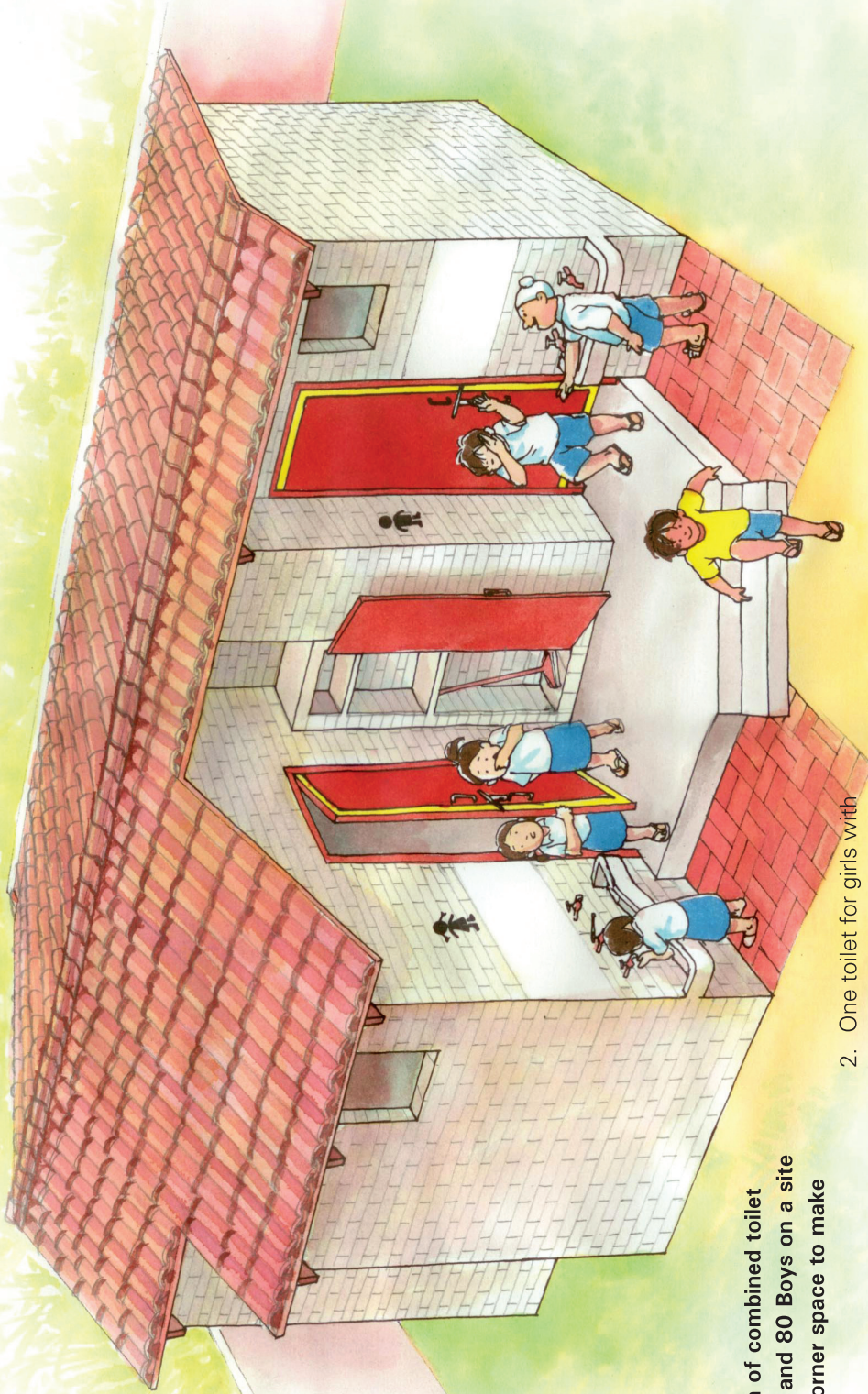

Basic Core Design of combined toilet block for 80 Girls and 80 Boys on a site with 'L' shaped corner space to make the toilets

Suitable when a combined toilet block for Girls and Boys is needed and the space available is 'L' shaped in the corner.

Total Built-up Area: 12.99 sq.m

Indicative cost* Rs 94,130

Additional salient features:

The design has:

1. Segregated entrances for girl's and boy's toilet blocks.

2. One toilet for girls with internal wash
3. Four girl's urinals
4. One toilet for boys with internal wash
5. Four boy's urinals
6. Thick common wall between boys and girl's toilet area.
7. Two external wash areas with provision for storage water tank.

ORIENTATION

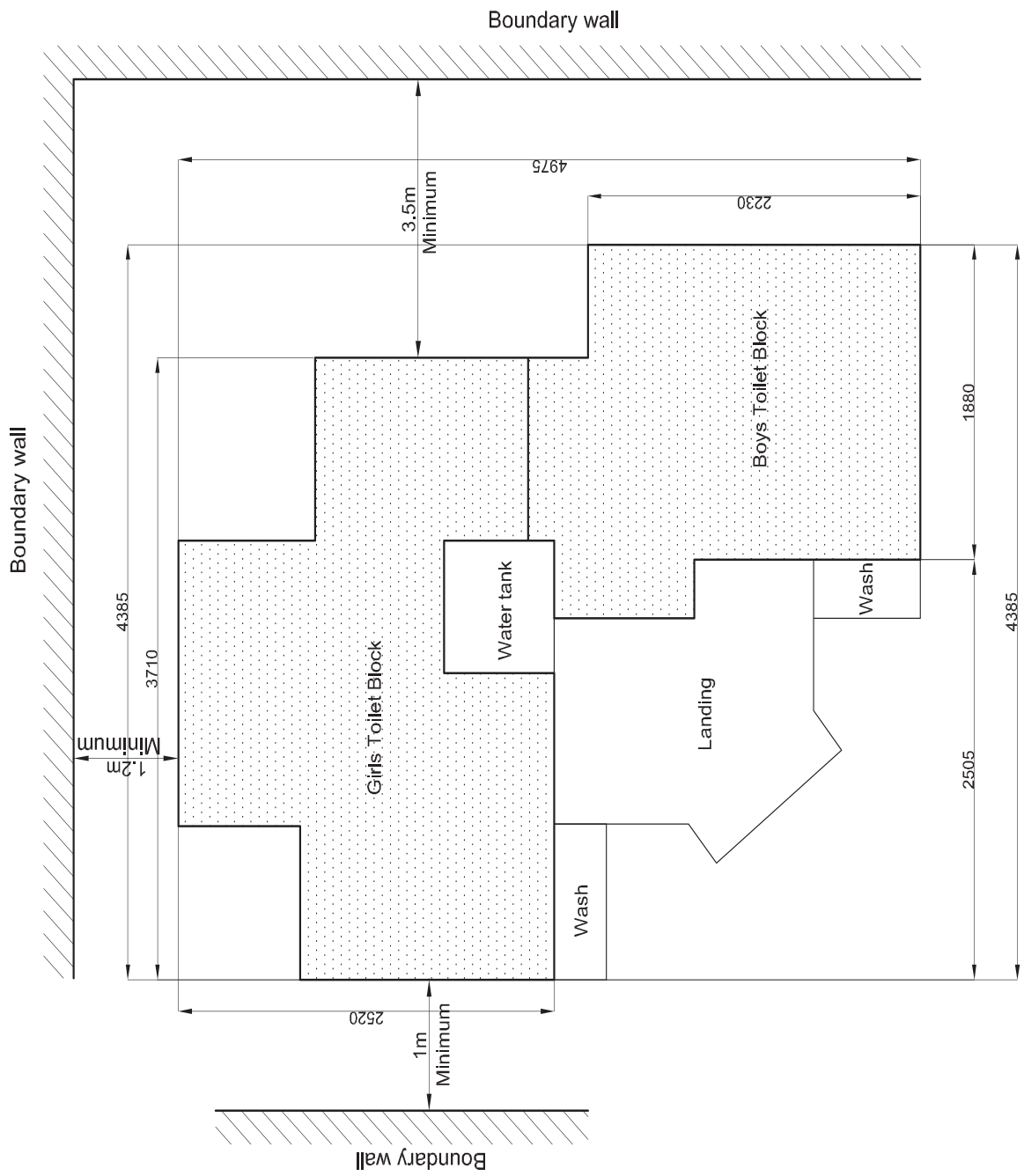

Plan – 12 BCD corner 80G+80B

Notes

- This design is valid for brick strength not below 35kg/sq.cm.
- Foundation design is only indicative & may need review based on local site conditions.
- For masonry water tank, the foundation shall be in 230mm brick up to the base of the tank.
- Mortar 1:4 for 115mm thick masonry. No reinforcement bars in alternate courses.
- This design is valid for earth quake zone I, II & III only
- No water supply or waste water carrying pipe shall be concealed in the masonry wall. It shall be exposed and fixed with clips and not chased in masonry walls.
- In case the masonry specification is changed from that given here, maintain the internal clear dimensions & the layout and provide suitable redesigned foundation.
- Stopping roof overhang and its anchorage design may need review in cyclone prone regions.
- In case roof specifications are changed from that given here (e.g. flat roof in stone or RCC) provide suitable strengthening of masonry while maintaining all internal clearances in the layout design.
- Only one metallic / masonry incinerator to be put along the location indicated as ICN.
- Incinerator to be provided only with Girls toilet and to have chute from inside.
- Location of leach pits, soak pits, waste drainage pipes & inspection chamber is indicative only. Actual location to be decided based on site conditions.
- Minimum distance of leaching pit from building foundation to be 125cm in different soil types.
- Design of leach pit shown is for 80x80-160 children with its volume sufficient for catering approximately six months in different soil types. For higher capacity or longer duration, design will need review.

Key to symbols:

- Pipe carrying waste water from wash area to flush urinals.
- Open / Covered drain for waste from Urinal / Squatting pan.
- Masonry wall.
- Roof line

12

Proposed Toilet Basic Core Design 80G + 80B Corner

Plan

Scale: 1:100

All dimensions are in mm.

North

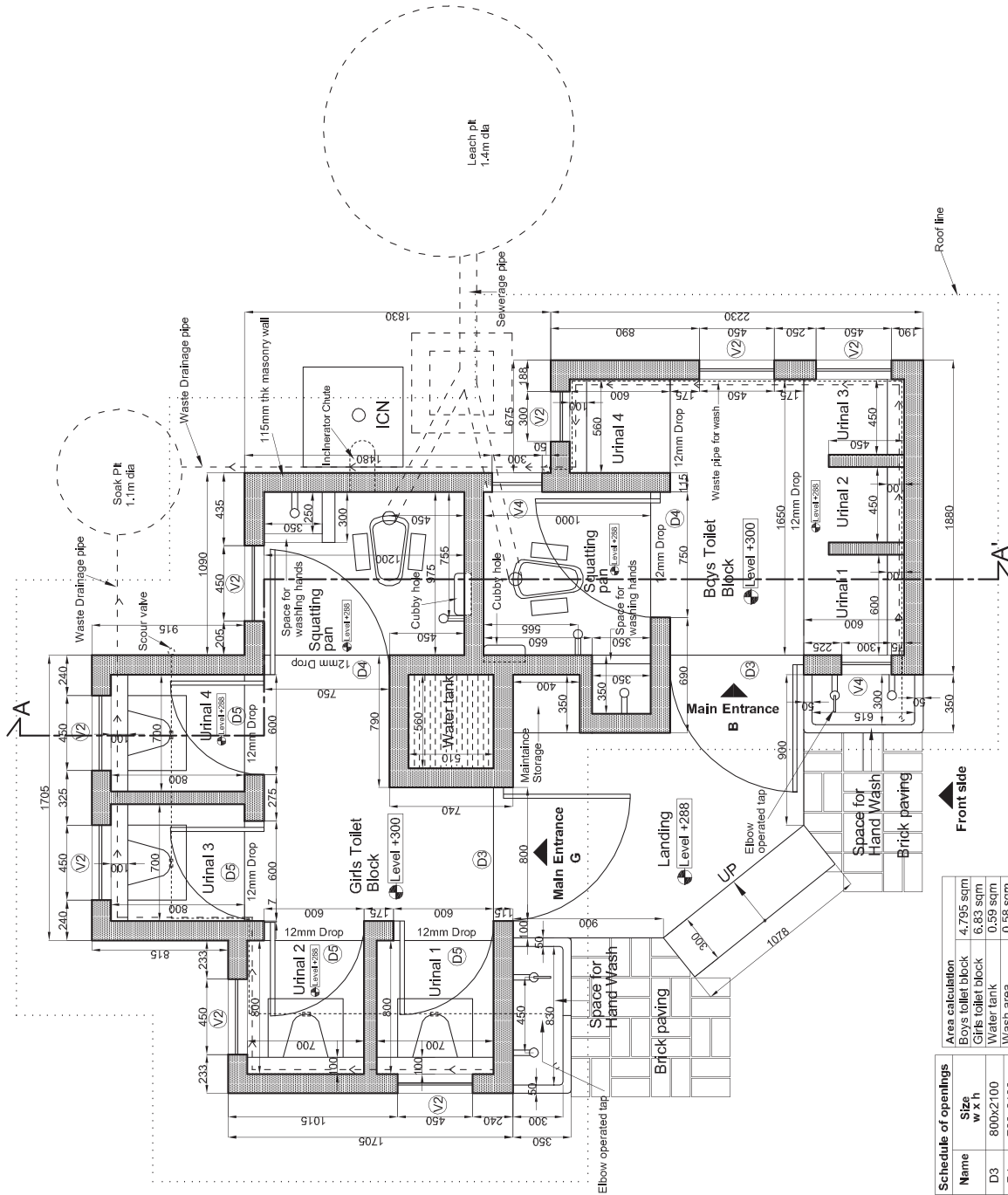

Plan

Schedule of openings		Area calculation	
Name	Size w x h		
D3	800x2100	Boys toilet block	4,795 sqm
D4	700x2100	Girls toilet block	6,83 sqm
D5	600x1500	Water tank	0,59 sqm
V2	450x450	Wash area	0,58 sqm
V4	300x450	Landing+Steps	2,45 sqm
		Common storage	0,19 sqm
		Total Overall Area	19,44 sqm
		Total Covered Area	12,89 sqm

Section & Details – 12 BCD corner 80G+80B

Suggested brief specifications:

- Civil work**
1. Pre-construction chemical termite treatment as per need.
 2. PCC 1:3:6 Cement: Coarse Sand: Coarse Aggregate in foundation.
 3. Foundation and Plinth in 1:4 cement mortar in brickwork.
 4. 75mm thick plinth band in 1:2:4 Reinforced Cement Concrete.
 5. Superstructure masonry in 1:4 cement mortar in 115 mm thick brick work.
 6. Pointing in 1:4 on exterior face.
 7. Plastering in 1:6 on interior face above dado level.
 8. All urinals and squatting pan area with ceramic tile floor and dado up to 750mm from finished floor.
 9. Use of waterproofing compound for plaster upto dado level and for fixing tile.
 10. All other flooring in cement concrete / stone tile as per availability. Slope in toilets & urinals floor is 1:50 or more.
 11. 150mm thick Lintel band in 1:2:4 Reinforced Cement Concrete.
 12. Built-in water tank with masonry walls and lining of waterproof cement plaster.
 13. Sloping roof in MCR / Country tile / Mangalore tile with metal / timber under-structure.
 14. Roof under-structure to be tied to masonry/finel band as per detail given.
 15. Door and ventilator frame in metal angle sections, painted with two coats of primer before installation.
 16. Door shutter in PVC/metal painted with two coats of primer and painted with enamel paint in light colour.
- Plumbing and Sanitary work**
17. All plumbing pipes in B class GI pipes with suitable elbow / tee / nipple / union / scour valves.
 18. All taps of best quality, locally available.
 19. All waste water carrying pipes in HDPE / PVC to flush urinals.
 20. All girls urinals squatting type in glazed ceramic type, white in colour.
 21. All squatting pan of rural pan type in glazed ceramic type, white in colour.
 22. All drainage and sewage pipes from Urinals / Squatting pan area in HDPE / PVC / CI / SW as per local availability.
 23. Leach pit with 115mm thick honeycomb brickwork in 1:4 cement sand mortar.

Schedule of openings	
Name	Size w x h
D3	800x2100
D4	700x2100
D5	600x1500
V2	450x450
V4	300x450

12

Proposed Toilet Basic Core Design 80 G+ 80 B Corner

Section and Details

Scale
200 100 0 250 500 750

All dimensions are in mm

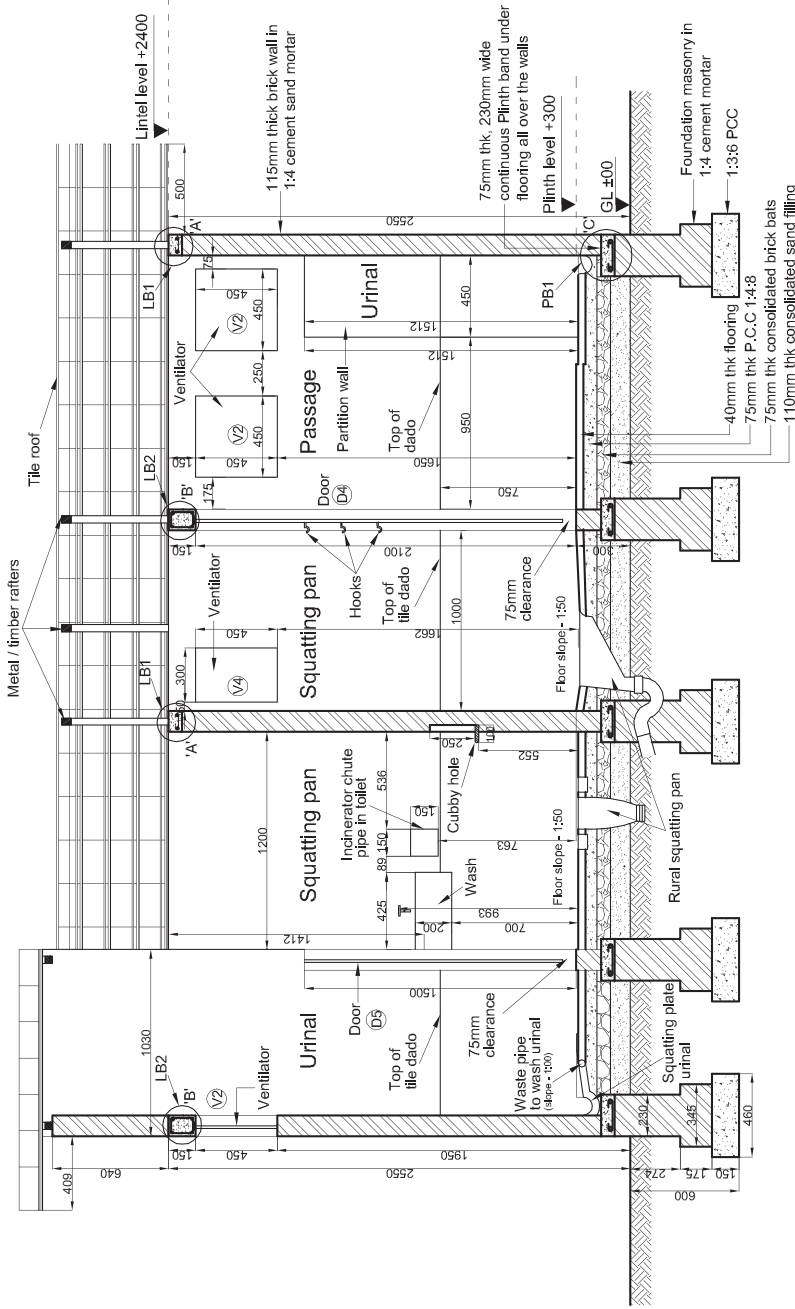

Boys Toilet Block

Section AA'

Girls Toilet Block

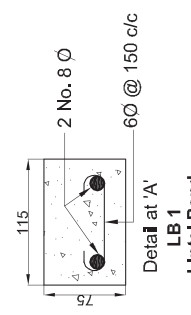
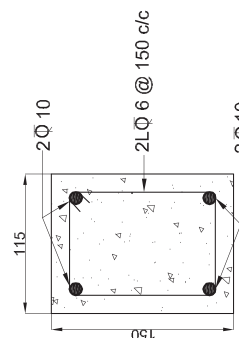
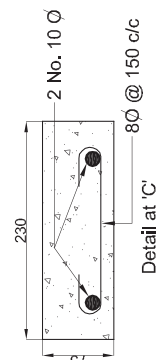

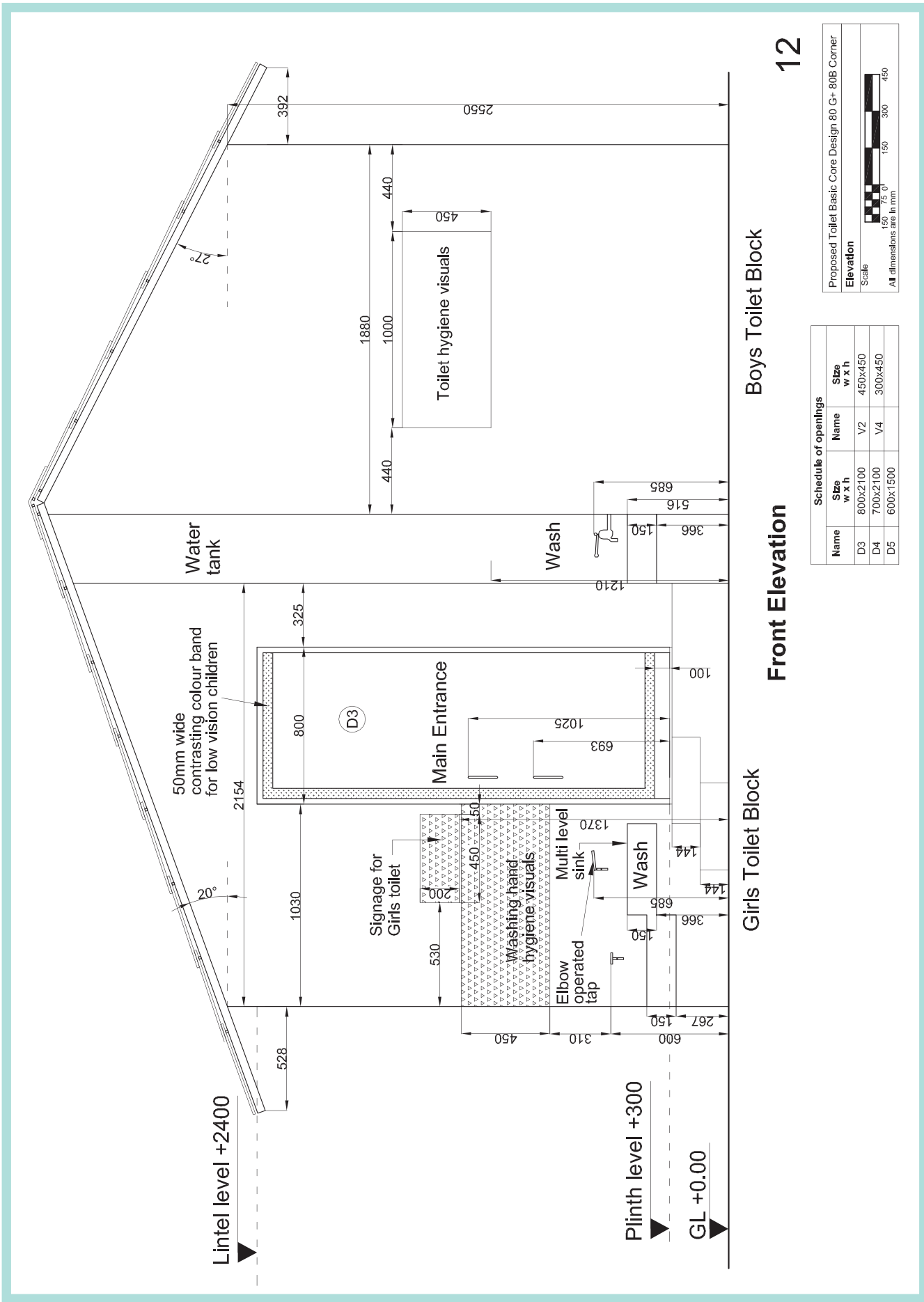

Boys Toilet Block

Front Elevation

Girls Toilet Block

12

Schedule of openings		
Name	Size w x h	Size w x h
D3	800x2100	450x450
D4	700x2100	300x450
D5	600x1500	

Proposed Toilet Basic Core Design 80 G+ 80B Corner
Elevation
 Scale

 All dimensions are in mm

Bill of quantities – 12 BCD corner 80G+80B

ITEM	UNIT	Quantity	Rate	Indexed rate	Amount
9	Tile work				
a	Ceramic tile work in floor	sq.m	5.7661	504.10	594.84
b	Ceramic tile work in dado	sq.m	18.66825	504.10	594.84
c	Antiskid tiles in Ramp	sq.m	406.15	479.26	11104.58
10	Sanitary fixtures				
a	Rural squatting pan	number	2	350.00	413.00
b	Girl's squatting urinal	number	4	300.00	354.00
11	Plumbing				
a	GI pipe water supply line (internal) +3m external	rn.m	10.1384	78.65	92.81
b	Taps	number	9	250.00	295.00
c	Waste water pipe for flushing	rn.m	9.5152	31.05	36.64
12	Sewage				
a	Sewage line from squatting pan to first IC + 3m	rn.m	5.3932	111.60	131.69
b	Waste drain line from urinal to first IC + 3m	rn.m	6.153	111.60	131.69
13	Roof work				
a	Roof area (sloping, with overhangs and overlaps)	sq.m	23.2011	700.00	700.00
14	Doors				
a	D1	number		500.00	590.00
b	D2	number		500.00	590.00
c	D3	number	2	500.00	590.00
d	D4	number	2	500.00	590.00
e	D5	number	4	500.00	590.00
f	Storage door shutter	number	1	500.00	590.00
15	Ventilators				
a	V1	number		350.00	413.00
b	V2	number	8	350.00	413.00
c	V3	number		350.00	413.00
d	V4	number	2	350.00	413.00
16	Incinerator				
a	Metal/ Masonry incinerator	number	1	1500.00	1500.00
17	Painting work				
a	Internal white washing	sq.m	45.0146	35.40	41.77
b	External wall painting	sq.m	40.146	30.00	35.40
c	Door and ventilator	sq.m	19.83	58	68.44
18	Metal Work				
a	Grab bars in toilets 40mm dia MS pipe	rn.m		32.10	37.88
b	Rail in 40mm dia MS pipe in ramp	rn.m		32.10	37.88
c	Vertical rail supports 25mm dia MS bars	rn.m		32.10	37.88

Total Amount Rs. 94130
Total Area Sq.m 12.99
Cost per sqm 7246

ITEM	UNIT	Quantity	Rate	Indexed rate	Amount
1	Excavation				
a	Foundation	cu.m	7.4660	30.00	264.30
b	Leach and soak pit	cu.m	4.2076	30.00	148.95
c	Ramp work	cu.m	30.00	35.4	35.4
2	PCC				
a	1:3:6 PCC in foundation	cu.m	1.7887	1678.00	3541.60
b	1:4:8 PCC in flooring	cu.m	0.9774	1503.60	1734.14
c	1:4:8 PCC in Ramp	cu.m		1503.60	1774.25
3	Back-filling				
a	Foundation	cu.m	2.1516	25.55	30.15
b	Sand fill under floor	cu.m	0.6921	95.60	112.81
c	Consolidated aggregate under floor	cu.m	0.6660	0.00	0.00
d	Infill in soak pit	cu.m	1.8997	25.55	30.15
e	Back fill in Ramp	cu.m		25.55	30.15
4	Brick work				
a	Brickwork in foundation and plinth	cu.m	3.7069	1452.9	1714.42
b	Brickwork in Ramp	cu.m		1452.90	1714.42
c	Honey comb brickwork in leach pit	sq.m	6.0540	216.45	255.41
d	75mm thk masonry partition in superstructure	sq.m	5.0183	119.4	140.89
e	115mm thick masonry in superstructure	sq.m	51.1984	199.00	234.82
f	230mm thick masonry in superstructure	cu.m	0.4280	1690.45	1994.73
g	Brick work in steps	cu.m	0.6614	1690.45	1994.73
h	Dry brick work in paving	sq.m	1.4131	80.85	95.40
5	RCC work				
a	1:2:4 RCC Plinth band	cu.m	0.4459	5209.75	6147.51
b	1:2:4 RCC Lintel band (all types)	cu.m	0.3297	5209.75	6147.51
c	1:2:4 PCC bed blocks for roof anchorage	cu.m	0.0238	2136.35	2520.89
6	Slab (Stone / precast RCC)				
a	125mm thk Slab under water tank	sq.m	0.5846	570.79	673.53
b	75mm thk Slab under hand wash areas (all)	sq.m	0.9955	342.47	404.11
c	50mm thk Partition shelves in storage	sq.m	0.6000	228.31	269.41
d	75mm thk Cover for water tank	sq.m	0.5846	342.47	404.11
e	75mm thk Cover for leach pit	sq.m	1.5386	342.47	404.11
7	Pointing and plastering				
a	1:4 pointing in exposed brick work	sq.m	40.1460	29.75	35.11
b	1:6 cement sand plastering	sq.m	45.0146	39.90	47.08
c	1:6 cement sand with waterproof plastering	sq.m	2.1675	32.73	38.62
8	Flooring				
a	Cement concrete flooring	sq.m	5.6868	143.85	169.74

cu.m – Cubic meter, sq.m – Square meter, rn.m – Running meter

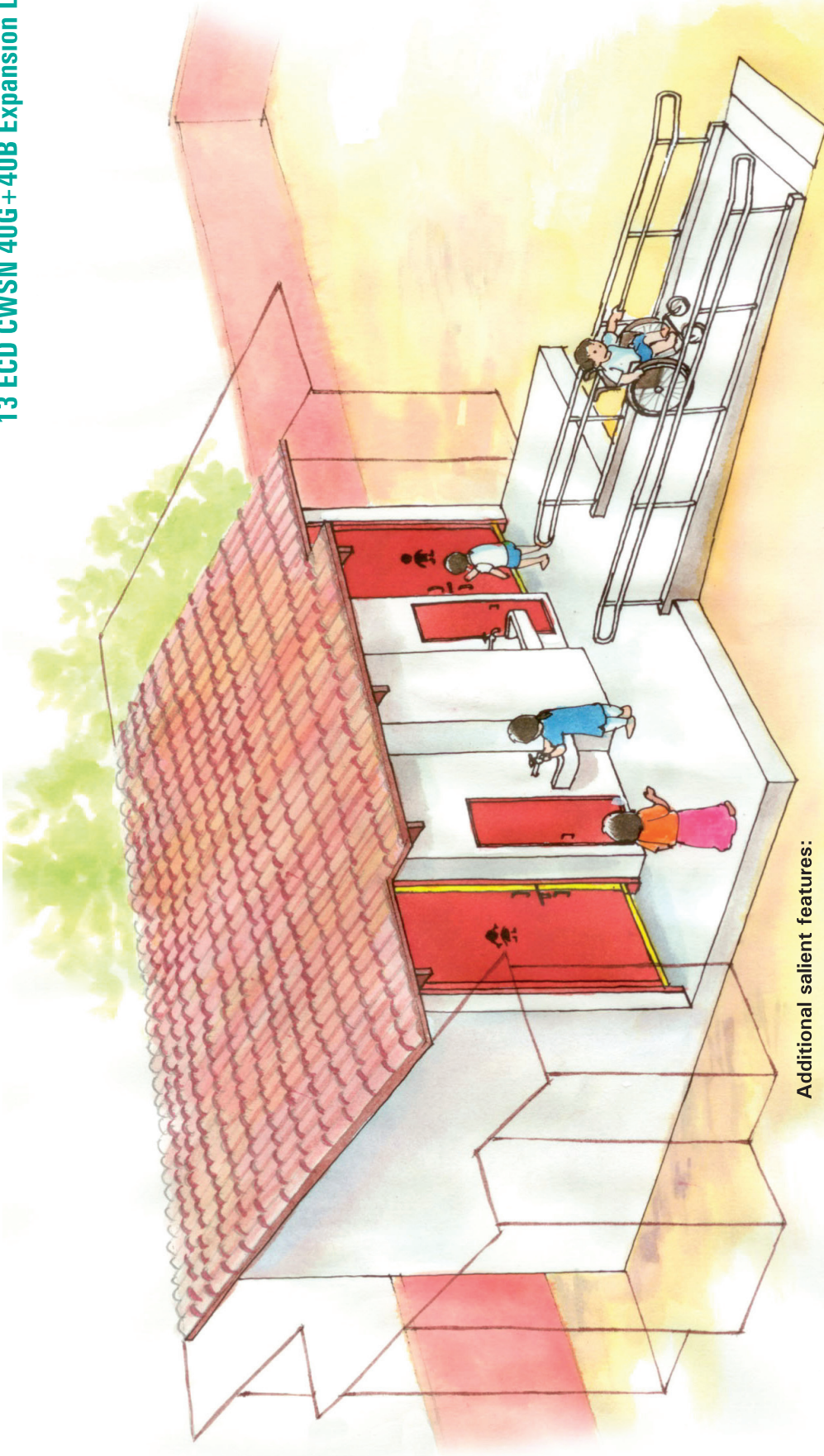

Expandable Core Design of combined toilet block for Children With Special Needs, 40 Girls and 40 Boys on a site with Linear space to make the toilets.

Suitable where there is scope for future expansion on sides. After first expansion this can serve total 80 Girls and 80 Boys.

Total Built-up Area: 15.5 sq.m
Indicative cost Rs 1,02,737

Additional salient features:

The design has:

1. Modular design for incremental growth in future. Expandable on sides.
2. Common ramp will serve both the boy's and girl's toilet. Common ramp, wash area can service all the modular expansions.
3. Segregated entrances for girl's and boy's toilet blocks.
4. One toilet for girls / CWSN with internal wash and provisions for internal grab bars and rails. With first expansion, one more toilet can be added (without CWSN provision)
5. Two girl's urinals. With each expansion, two more girl's urinals can be added.
6. One toilet for boys / CWSN with internal wash and provisions for internal grab bars and rails. With first expansion, one more toilet can be added (without CWSN provision)
7. Two boy's urinals. With each expansion, two more boy's urinals can be added.
8. Thick common wall between boys and girl's toilet area.
9. Two external wash areas with provision for storage water tank.

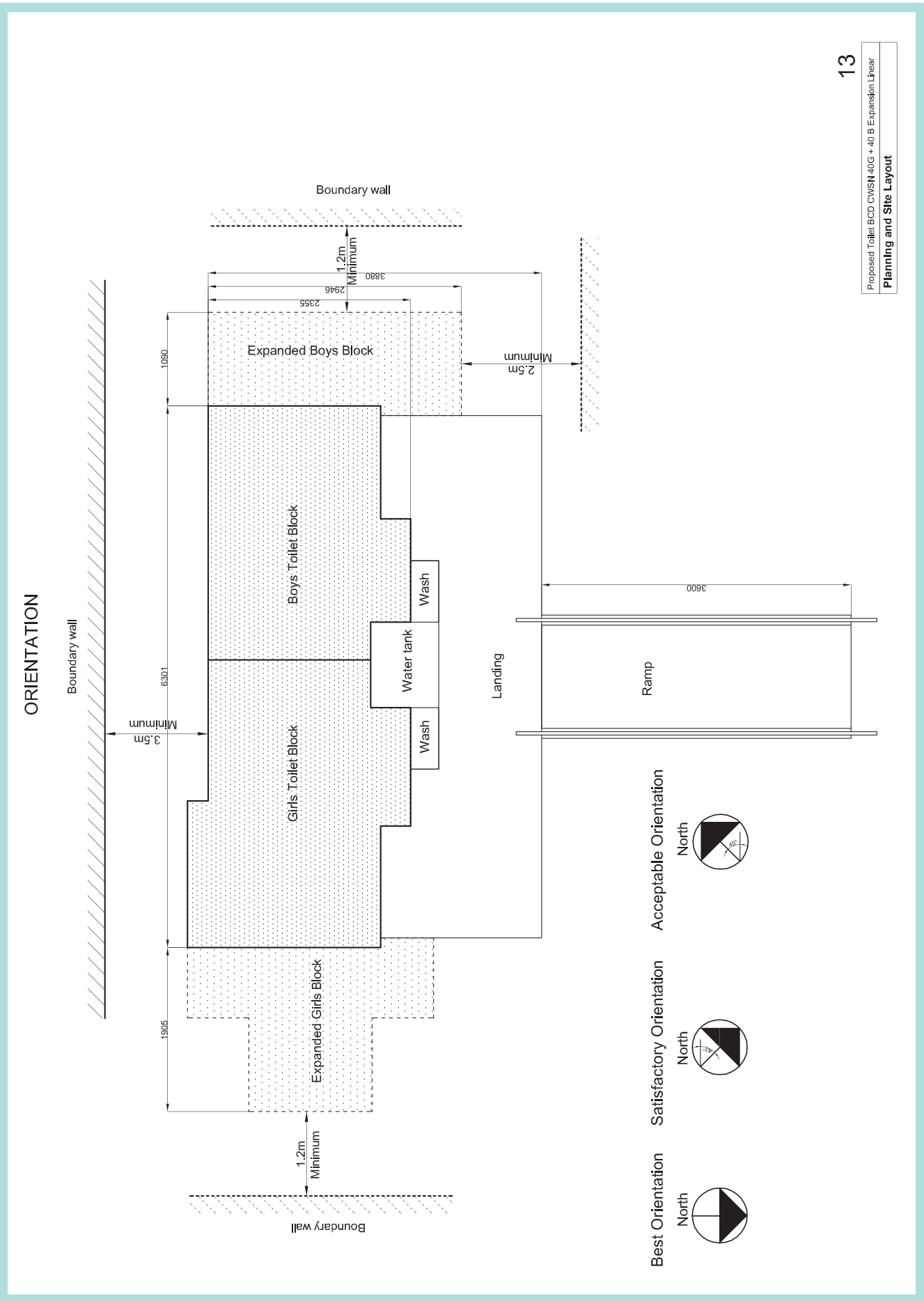

Plan – 13 ECD CWSN 40G + 40B Expansion Linear

Notes

- This design is valid for brick strength not below 35kg/sq.cm.
- Foundation design is only indicative & may need review based on local site conditions.
- For masonry water tank, the foundation shall be in 230mm brick up to the base of the tank.
- Mortar 1:4 for 115mm thick masonry. No reinforcement bars in alternate courses.
- This design is valid for earth quake zone I, II & III only.
- No water supply or waste water carrying pipe shall be concealed in the masonry wall. It shall be exposed and fixed with clips and not chased in masonry walls.
- In case the masonry specification is changed from that given here, maintain the internal clear dimensions & the layout and provide suitable redesigned foundation.
- Stopping roof overhang and its anchorage design may need review in cyclone prone regions.
- In case roof specifications are changed from that given here (e.g. flat roof in stone or RCC) provide suitable strengthening of masonry while maintaining all internal clearances in the layout design.
- Only one metallic / masonry Incherator to be put along the location indicated as ICN.
- Incherator to be provided only with G1's toilet and to have chute from inside.
- Location of leach pits, soak pits, waste drainage pipes & Inspection chamber is indicative only. Actual location to be decided based on site conditions.
- Minimum distance of leaching pit from building foundation to be 125cm in different soil types.
- Design of leach pit shown is for 40-40=80 children with its volume sufficient for catering approximately one year in different soil types. For higher capacity or longer duration, design will need review.

Key to symbols:

- Pipe carrying waste water from wash area to flush urinals.
- Open / Covered draft for waste from Urinal / Squatting pan.
- Masonry wall.
- Roof line

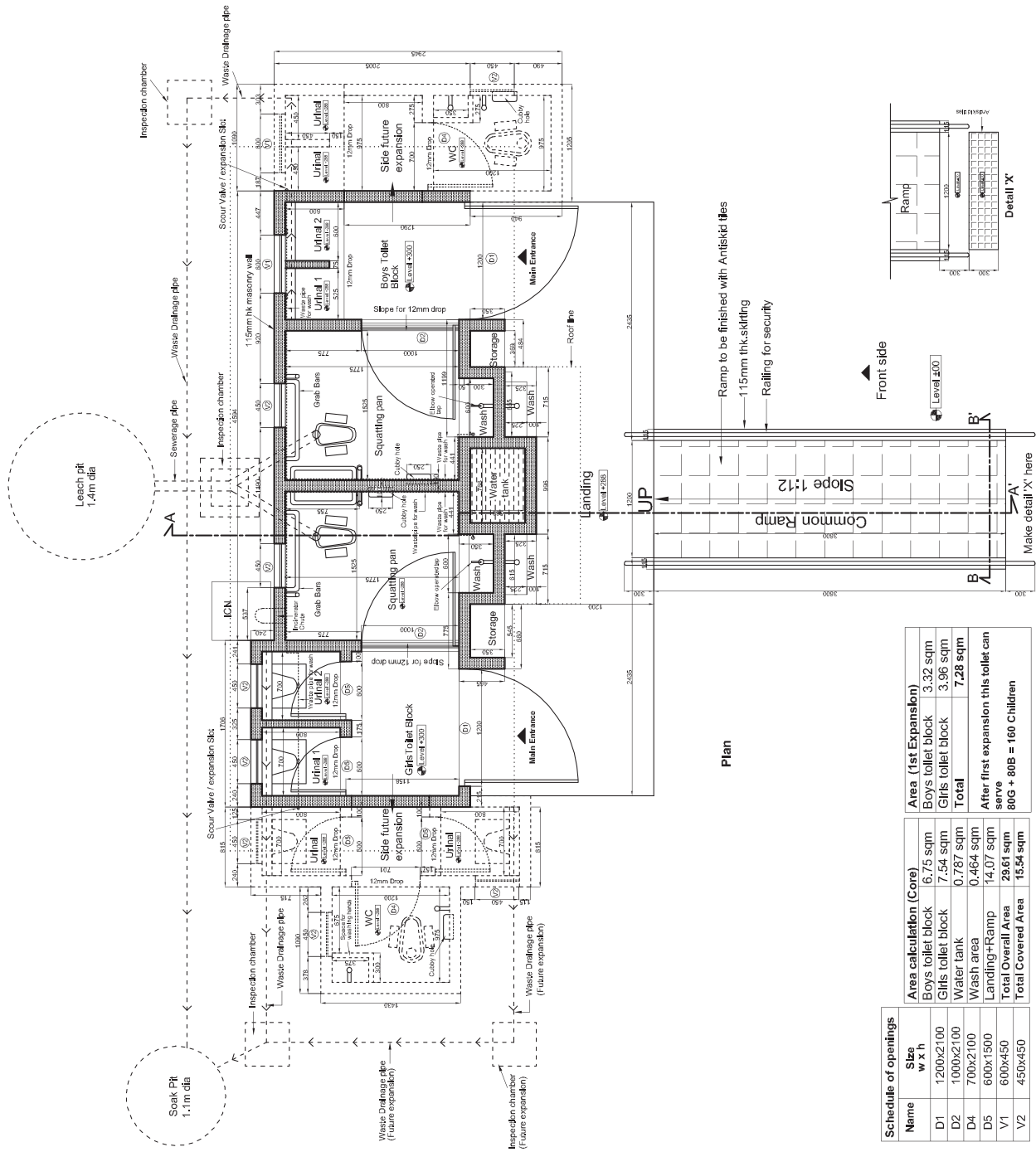

Area (1st Expansion)	
Boys toilet block	3.32 sqm
Girls toilet block	3.96 sqm
Total	7.28 sqm

Area calculation (Core)	
Boys toilet block	6.75 sqm
Girls toilet block	7.54 sqm
Water tank	0.787 sqm
Wash area	0.464 sqm
Landing+Ramp	14.07 sqm
Total Overall Area	29.61 sqm
Total Covered Area	15.54 sqm

Schedule of openings	
Name	Size w x h
D1	1200x2100
D2	1000x2100
D4	700x2100
D5	600x1500
V1	600x450
V2	450x450

After first expansion this toilet can serve 80G + 80B = 160 Children

13

Proposed Toilet BCD CWSN 40G + 40 B Expansion Linear

Plan

Scale

All dimensions are in mm

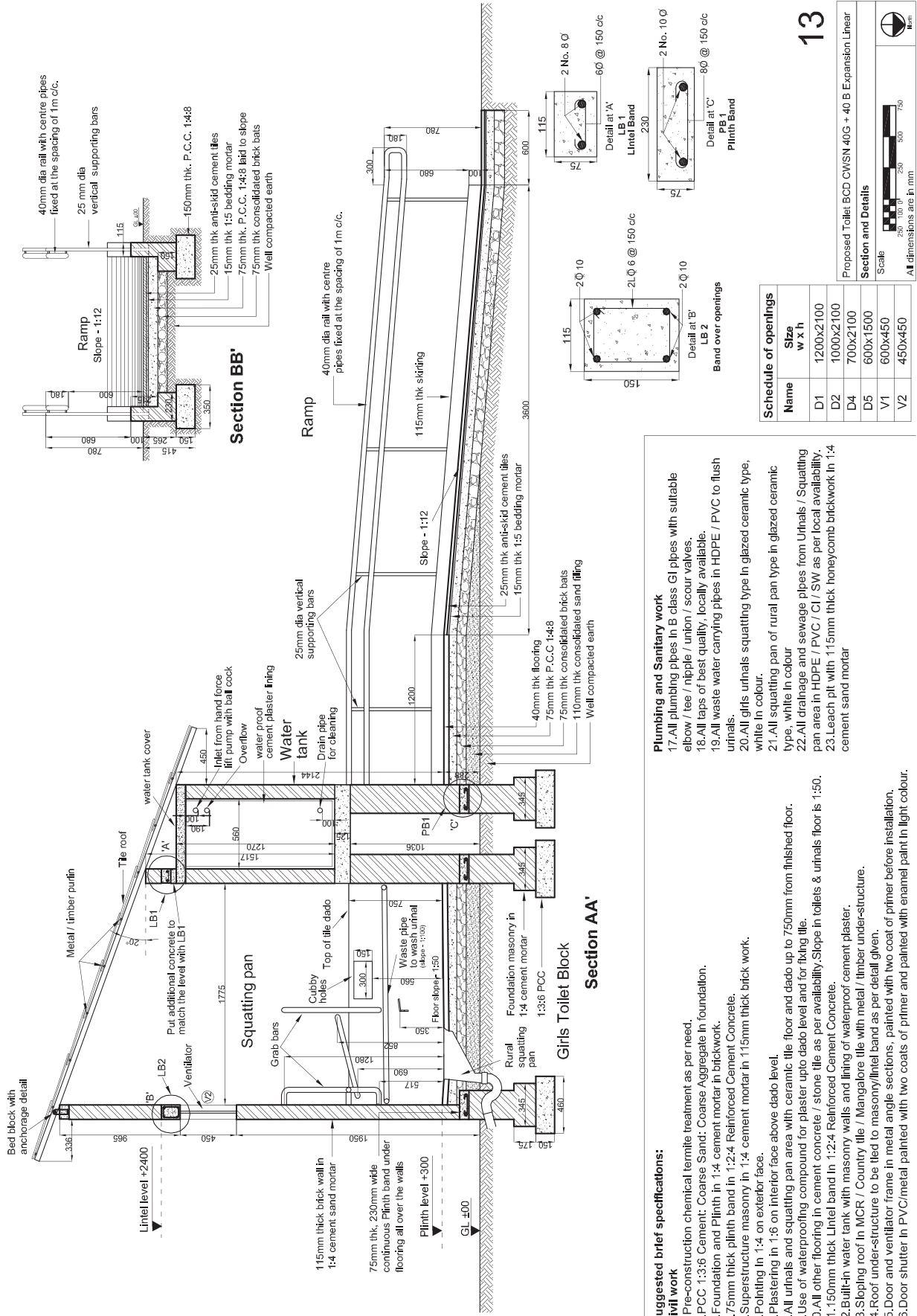

Top level +3600

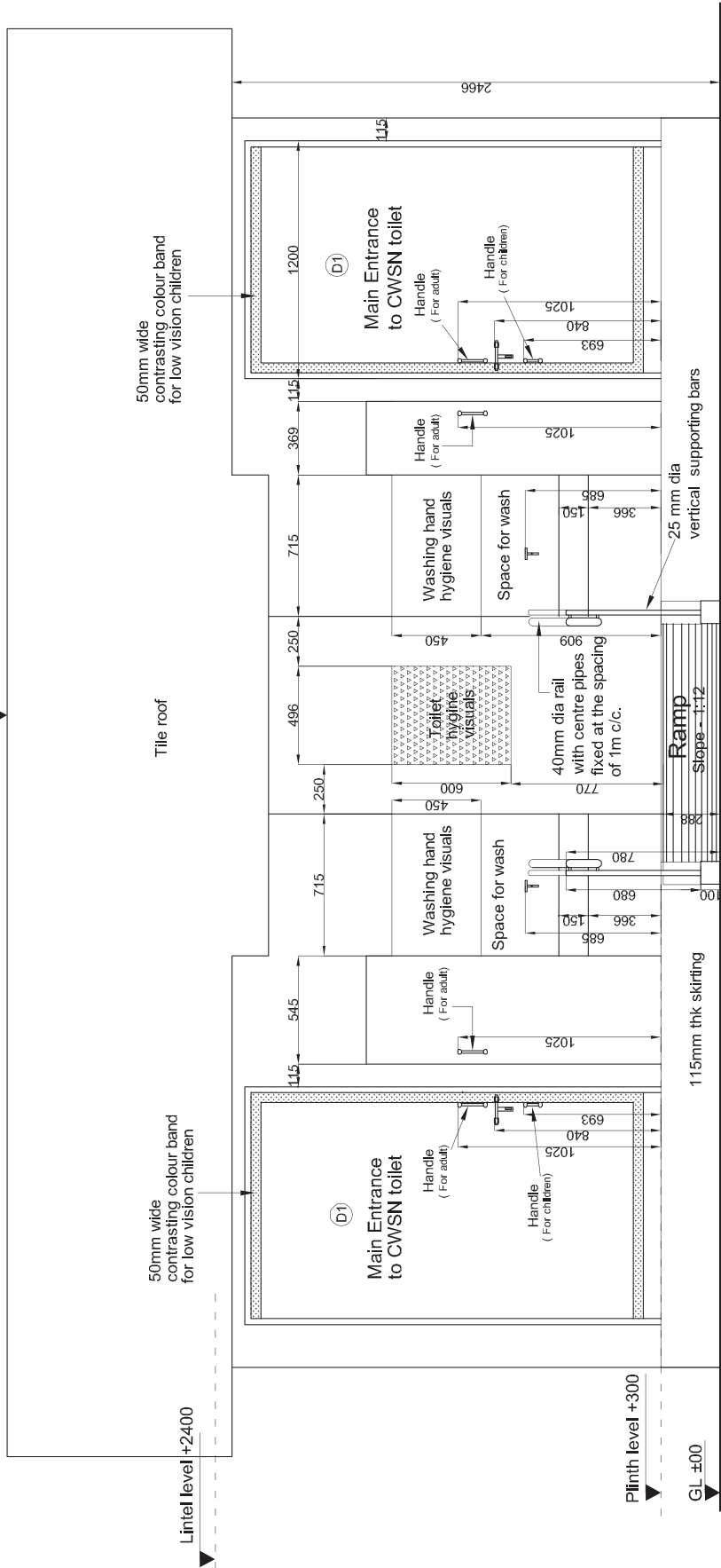

Boys Toilet Block

Front Elevation

Girls Toilet Block

Schedule of openings	
Name	Size w x h
D1	1200x2100
D2	1000x2100
D4	700x2700
D5	600x1500
V1	600x450
V2	450x450

Proposed Toilet BCD CWSN 40G + 40 B Expansion Linear

Elevation

Scale



13

Bill of quantities – 13 ECD CWSN 40G +40B Expansion Linear

ITEM	UNIT	Quantity	Rate	Indexed rate	Amount
1 Excavation					
a Foundation	cu.m	7.6120	30.00	35.4	269.46
b Leach and soak pit	cu.m	4.2076	30.00	35.4	148.95
c Ramp work	cu.m	2.1405	30.00	35.4	75.77
2 PCC					
a 1:3:6 PCC in foundation	cu.m	1.9030	1678.00	1980.04	3768.01
b 1:4:8 PCC in flooring	cu.m	0.8488	1503.60	1774.25	1506.02
c 1:4:8 PCC in Ramp	cu.m	2.3725	1503.60	1774.25	4209.40
3 Back-filling					
a Foundation	cu.m	2.2891	25.55	30.15	69.01
b Sand fill under floor	cu.m	2.0551	95.60	112.81	231.83
c Consolidated aggregate under floor	cu.m	1.8710		0.00	0.00
d Infill in soak pit	cu.m	1.8997	25.55	30.15	57.27
e Back fill in Ramp	cu.m	0.0591	25.55	30.15	1.78
4 Brick work					
a Brickwork in foundation and plinth	cu.m	3.9439	1452.9	1714.42	6761.50
b Brickwork in Ramp	cu.m	1.1888	1452.90	1714.42	2038.10
c Honey comb brickwork in leach pit	sq.m	6.0540	216.45	255.41	1546.26
d 75mm thk masonry partition in superstructure	sq.m	2.1338	119.4	140.89	300.64
e 115mm thick masonry in superstructure	sq.m	60.3594	199.00	234.82	14173.59
f 230mm thick masonry in superstructure	cu.m	0.5304	1690.45	1994.73	1058.01
g Brick work in steps	cu.m		1690.45	1994.73	0.00
h Dry brick work in paving	sq.m		80.85	95.40	0.00
5 RCC work					
a 1:2:4 RCC Plinth band	cu.m	0.4744	5209.75	6147.51	2916.20
b 1:2:4 RCC Lintel band (all types)	cu.m	0.3211	5209.75	6147.51	1973.96
c 1:2:4 PCC bed blocks for roof anchorage	cu.m	0.0238	2136.35	2520.89	60.01
6 Slab (Stone / precast RCC)					
a 125mm thk Slab under water tank	sq.m	0.7870	570.79	673.53	530.07
b 75mm thk Slab under hand wash areas (all)	sq.m	1.1338	342.47	404.11	458.19
c 50mm thk Partition shelves in storage	sq.m	1.3368	228.31	269.41	360.14
d 75mm thk Cover for water tank	sq.m	0.7870	342.47	404.11	318.04
e 75mm thk Cover for leach pit	sq.m	1.5386	342.47	404.11	621.77
7 Pointing and plastering					
a 1:4 pointing in exposed brick work	sq.m	39.3965	29.75	35.11	1383.01
b 1:6 cement sand plastering	sq.m	54.6181	39.90	47.08	2571.53
c 1:6 cement sand with waterproof plastering	sq.m	2.3363	32.73	38.62	90.23
8 Flooring					
a Cement concrete flooring	sq.m	13.1796	143.85	169.74	2237.14

cu.m – Cubic meter, sq.m – Square meter, m.m – Running meter

ITEM	UNIT	Quantity	Rate	Indexed rate	Amount
9 Tile work					
a Ceramic tile work in floor	sq.m	7.8706	504.10	594.84	4681.73
b Ceramic tile work in dado	sq.m	15.525	504.10	594.84	9234.86
c Antiskid tiles in Ramp	sq.m	4.6956	406.15	479.26	2250.40
10 Sanitary fixtures					
a Rural squatting pan	number	2	350.00	413.00	826.00
b Girl's squatting urinal	number	2	300.00	354.00	708.00
11 Plumbing					
a GI pipe water supply line (internal) +3m external	m.m	5.344	78.65	92.81	495.96
b Taps	number	6	250.00	295.00	1770.00
c Waste water pipe for flushing	m.m	11.6	31.05	36.64	425.01
12 Sewage					
a Sewage line from squatting pan to first IC + 3m	m.m	4.9997	111.60	131.69	658.40
b Waste drain line from urinal to first IC + 3m	m.m	7.652	111.60	131.69	1007.68
13 Roof work					
a Roof area (sloping, with overhangs and overlaps)	sq.m	23.1271	700.00	700.00	16188.97
14 Doors					
a D1	number	2	500.00	590.00	1180.00
b D2	number	2	500.00	590.00	1180.00
c D3	number		500.00	590.00	0.00
d D4	number		500.00	590.00	0.00
e D5	number	2	500.00	590.00	1180.00
f Storage door shutter	number	2	500.00	590.00	1180.00
15 Ventilators					
a V1	number	1	350.00	413.00	413.00
b V2	number	4	350.00	413.00	1652.00
c V3	number		350.00	413.00	
d V4	number		350.00	413.00	0.00
16 Incinerator					
a Metal / Masonry incinerator	number	1	1500.00	1500.00	1500.00
17 Painting work					
a Internal white washing	sq.m	54.6181	35.40	41.77	2281.51
b External wall painting	sq.m	39.3965	30.00	35.40	1394.64
c Door and ventilator	sq.m	26.1779	58	68.44	1791.62
18 Metal Work					
a Grab bars in toilets 40mm dia MS pipe	m.m	4.1448	32.10	37.88	157.00
b Rail in 40mm dia MS pipe in ramp	m.m	15.7791	32.10	37.88	597.68
c Vertical rail supports 25mm dia MS bars	m.m	6.52	32.10	37.88	246.96

Total Amount Rs. 102737
Total Area Sq.m 15.54
Cost per sqm 6611

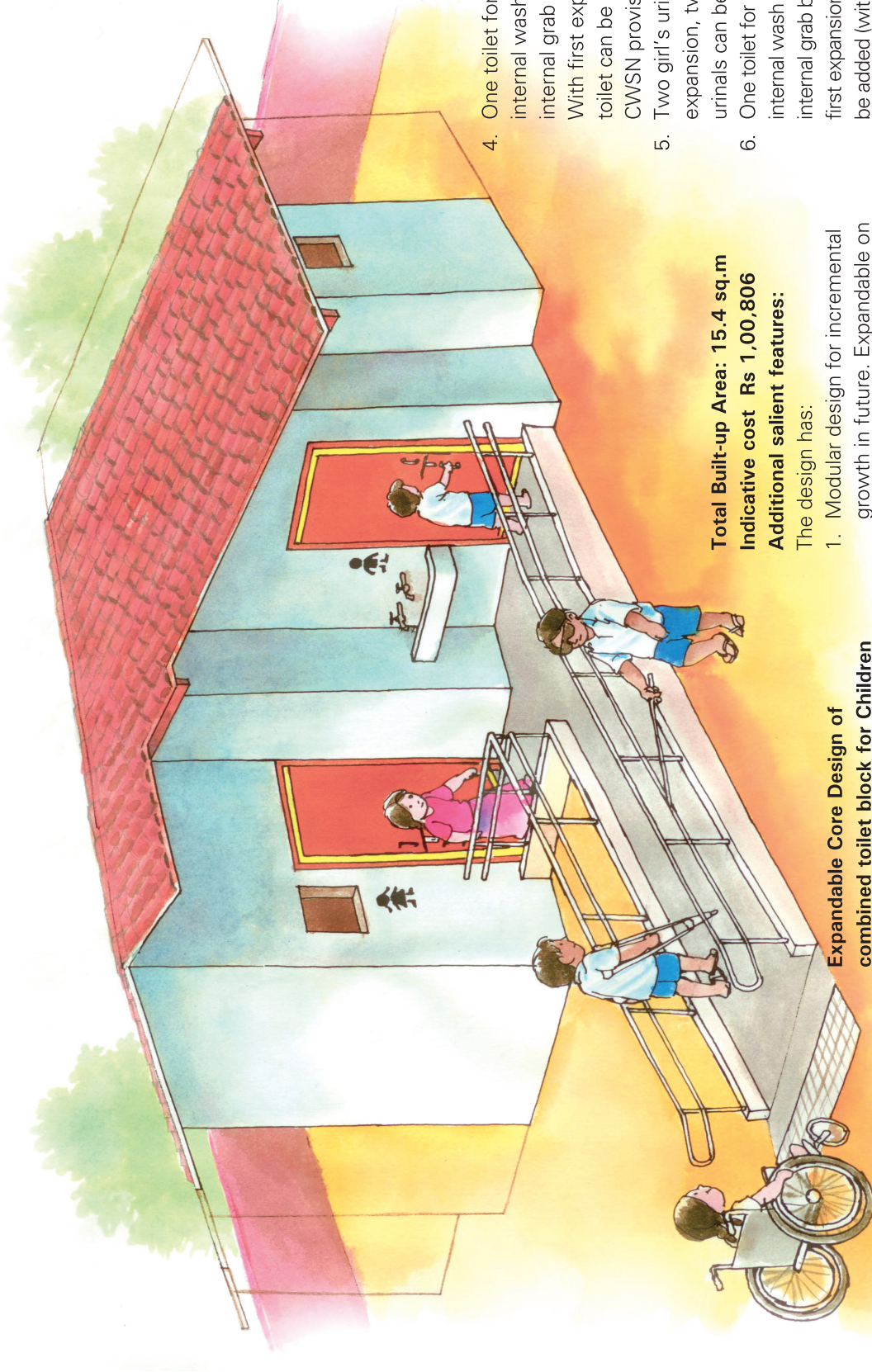

Expandable Core Design of combined toilet block for Children With Special Needs, 40 Girls and 40 Boys on a site with 'L' shaped space to make the toilets.

Suitable where there is scope for future expansion towards rear. After first expansion this can serve total 80 Girls and 80 Boys.

4. One toilet for girls / CWSN with internal wash and provisions for internal grab bars and rails. With first expansion, one more toilet can be added (without CWSN provision).
5. Two girl's urinals. With each expansion, two more girl's urinals can be added.
6. One toilet for boys / CWSN with internal wash and provisions for internal grab bars and rails. With first expansion, one more toilet can be added (without CWSN provision)
7. Two boy's urinals. With each expansion, two more boy's urinals can be added.
8. Thick common wall between boys and girl's toilet area.
9. Common external wash areas with provision for storage water tank.

Total Built-up Area: 15.4 sq.m
Indicative cost Rs 1,00,806
Additional salient features:

The design has:

1. Modular design for incremental growth in future. Expandable on the rear.
2. Common ramp will serve both the boy's and girl's toilet. Common ramp, wash area can service all the modular expansions.
3. Segregated entrances for girl's and boy's toilet blocks.

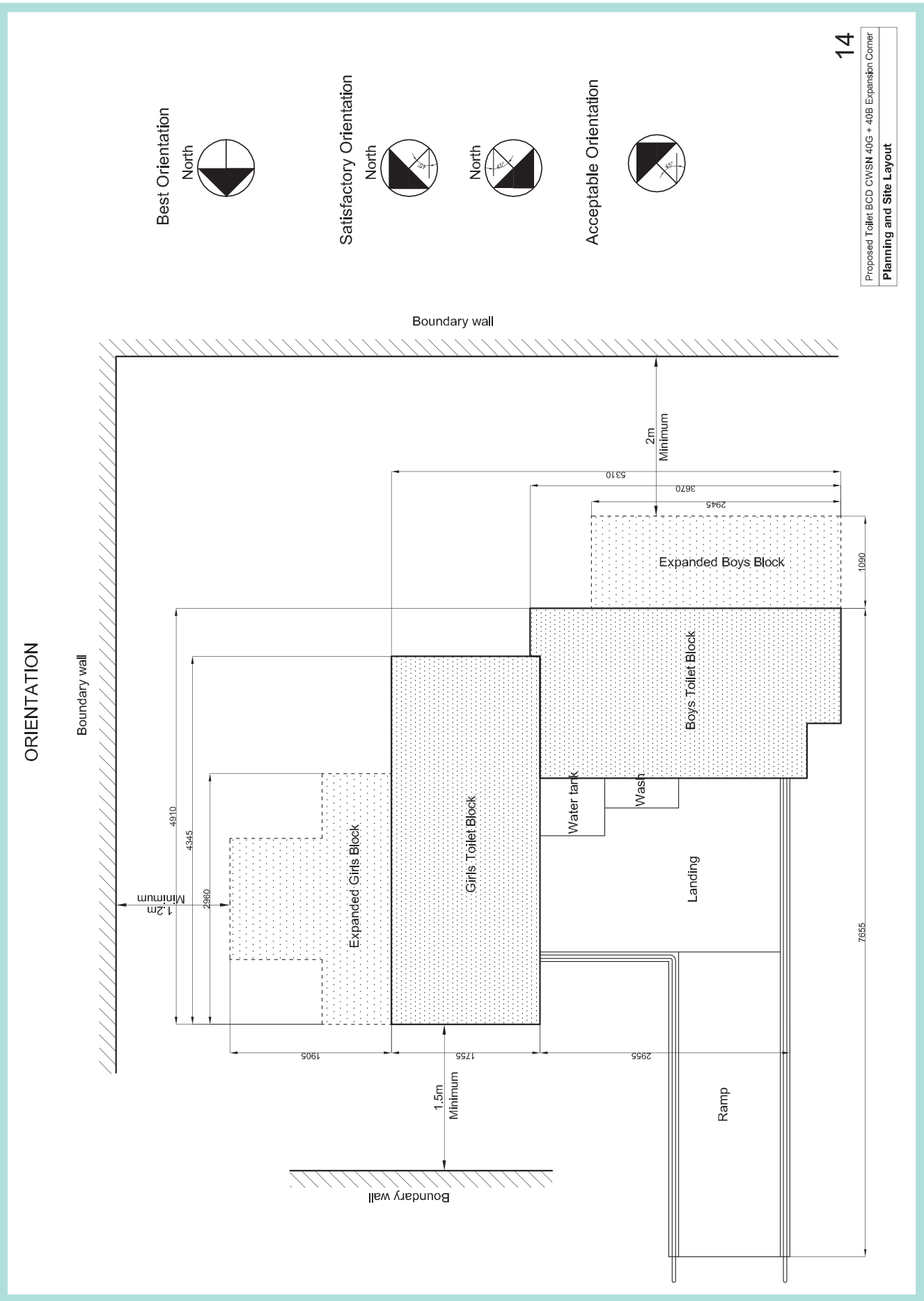

Notes

- This design is valid for brick strength not below 35kg/sq.cm.
- Foundation design is only indicative & may need review based on local site conditions.
- For masonry water tank, the foundation shall be in 230mm brick up to the base of the tank.
- Mortar 1:4 for 115mm thick masonry. No reinforcement bars in alternate courses.
- This design is valid for earth quake zone I, II & III only
- No water supply or waste water carrying pipe shall be concealed in the masonry wall. It shall be exposed and fixed with clips and not chased in masonry walls.
- In case the masonry specification is changed from that given here, maintain the internal clear dimensions & the layout and provide suitable redesigned foundation.
- Sloping roof overhang and its anchorage design may need review in cyclone prone regions.
- In case roof specifications are changed from that given here (e.g. flat roof in stone or RCC) provide suitable strengthening of masonry while maintaining all internal clearances in the layout design.
- Only one metallic / masonry incinerator to be put along the location indicated as ICN.
- Incinerator to be provided only with Girl's toilet and to have chute from inside.
- Location of leach pits, soak pits, waste drainage pipes & inspection chamber is indicative only. Actual location to be decided based on site conditions.
- Minimum distance of leaching pit from building foundation to be 125cm in different soil types.
- Design of leach pit shown is for 40-40=80 children with its volume sufficient for catering approximately one year in different soil types. For higher capacity or longer duration, design will need review.

Key to symbols:

- Pipe carrying waste water from wash area to flush urinals.
- - - - - Open / Covered draft for waste from Urinal / Squatting pan.
- ▨ Masonry wall.
- Roof line

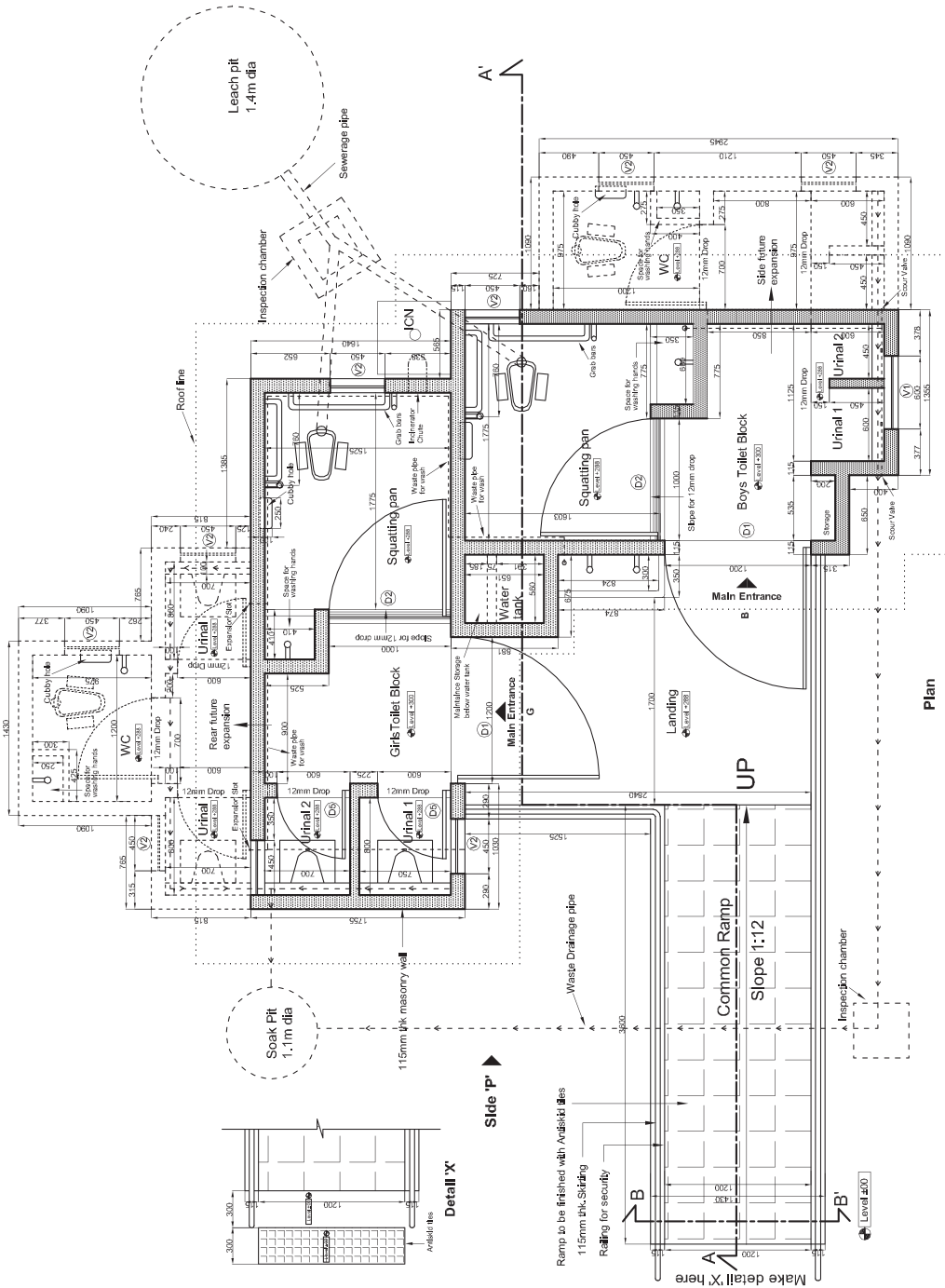

Schedule of openings	
Name	Size w x h
D1	1200x2100
D2	1000x2100
D5	600x1500
V1	600x450
V2	450x450

Area calculation (Core)	
Boys toilet block	6.93 sqm
Girls toilet block	7.63 sqm
Water tank	0.52 sqm
Wash area	0.31 sqm
Landing+Ramp	10.56 sqm
Total Overall Area	25.95 sqm
Total Covered Area	15.39 sqm

Area (1st Expansion)	
Boys toilet block	3.21 sqm
Girls toilet block	3.97 sqm
Total	7.18 sqm

After first expansion this toilet can serve 80G + 80B = 160 Children

Plan

Scale: 1:50, 1:100, 1:200, 1:300, 1:400

All dimensions are in mm

Section & Details – 14 ECD CWSN 40G + 40B Expansion Corner

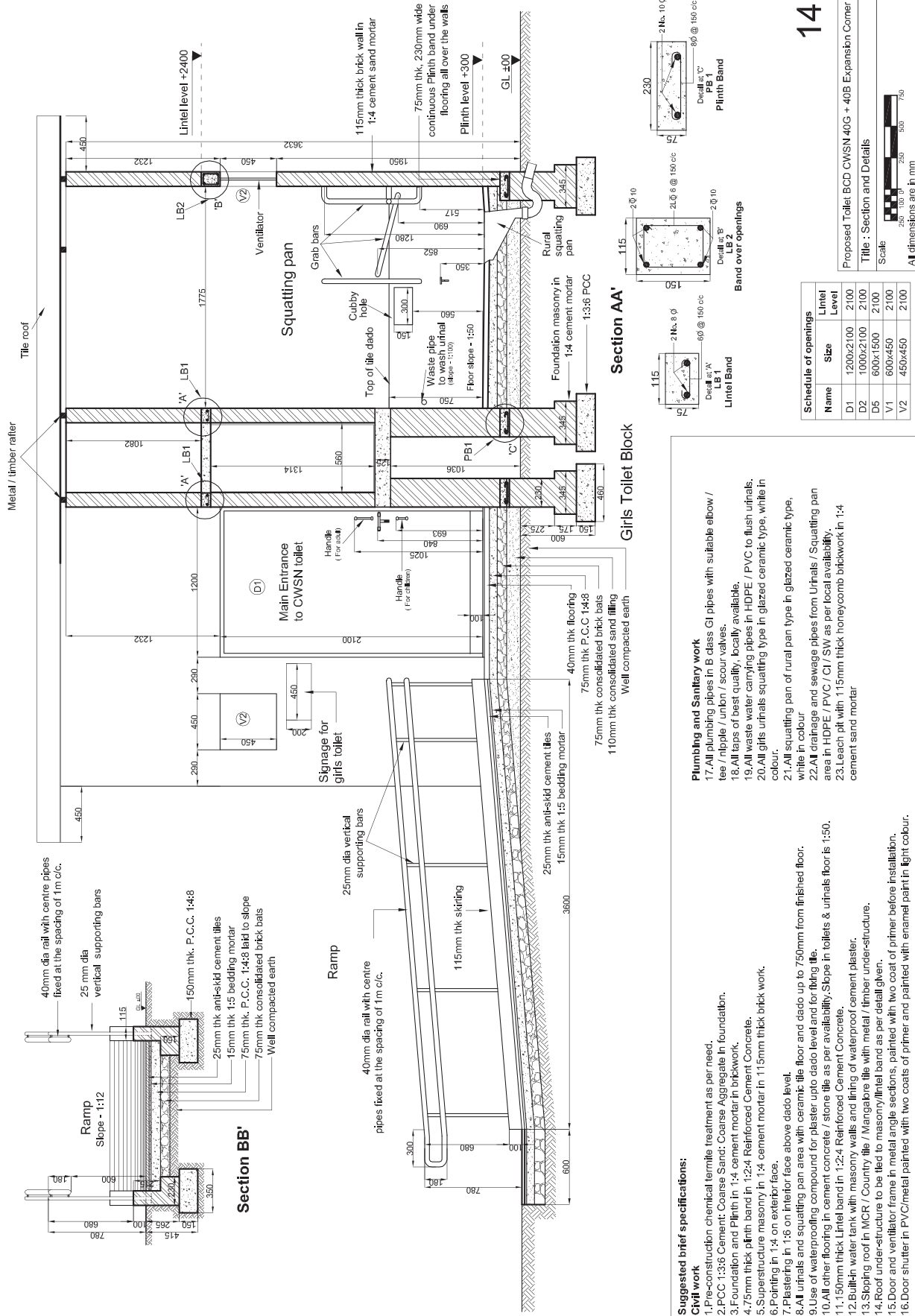

14

Proposed Toilet BCD CWSN 40G + 40B Expansion Corner
 Title : Section and Details
 Scale : 1:50
 All dimensions are in mm

- Suggested brief specifications:**
1. Pre-construction chemical termite treatment as per need.
 2. PCC 1:3:6 Cement, Coarse Sand; Coarse Aggregate in foundation.
 3. Foundation and Plinth in 1:4 cement mortar in brickwork.
 4. 75mm thick plinth band in 1:2:4 Reinforced Cement Concrete.
 5. Superstructure masonry in 1:4 cement mortar in 115mm thick brick work.
 6. Pointing in 1:4 on exterior face.
 7. Plastering in 1:6 on interior face above dado level.
 8. All urinals and squatting pan area with ceramic tile floor and dado up to 750mm from finished floor.
 9. Use of waterproofing compound for plaster upto dado level and for fixing tile.
 10. All other flooring in cement concrete / stone tile as per availability. Slope in toilets & urinals floor is 1:50.
 11. 150mm thick Lintel band in 1:2:4 Reinforced Cement Concrete.
 12. Bulk in water tank with masonry walls and lining of waterproof cement plaster.
 13. Sloping roof in MCR / Country tile / Mangalore tile with metal / timber under-structure.
 14. Roof under-structure to be tied to masonry/lintel band as per detail given.
 15. Door and ventilator frame in metal angle sections, painted with two coats of primer and painted with enamel paint in light colour.
 16. Door shutter in PVC/metal painted with two coats of primer and painted with enamel paint in light colour.
- Plumbing and Sanitary work**
17. All plumbing pipes in B class GI pipes with suitable elbow / tee / nipple / union / scour valves.
 18. All taps of best quality, locally available.
 19. All waste water carrying pipes in HDPE / PVC / PVC / SW as per local availability.
 20. All girls urinals squatting type in glazed ceramic type, white in colour.
 21. All squatting pan of rural pan type in glazed ceramic type, white in colour
 22. All drainage and sewage pipes from Urinals / Squatting pan area in HDPE / PVC / CI / SW as per local availability.
 23. Leach pit with 115mm thick honeycomb brickwork in 1:4 cement sand mortar

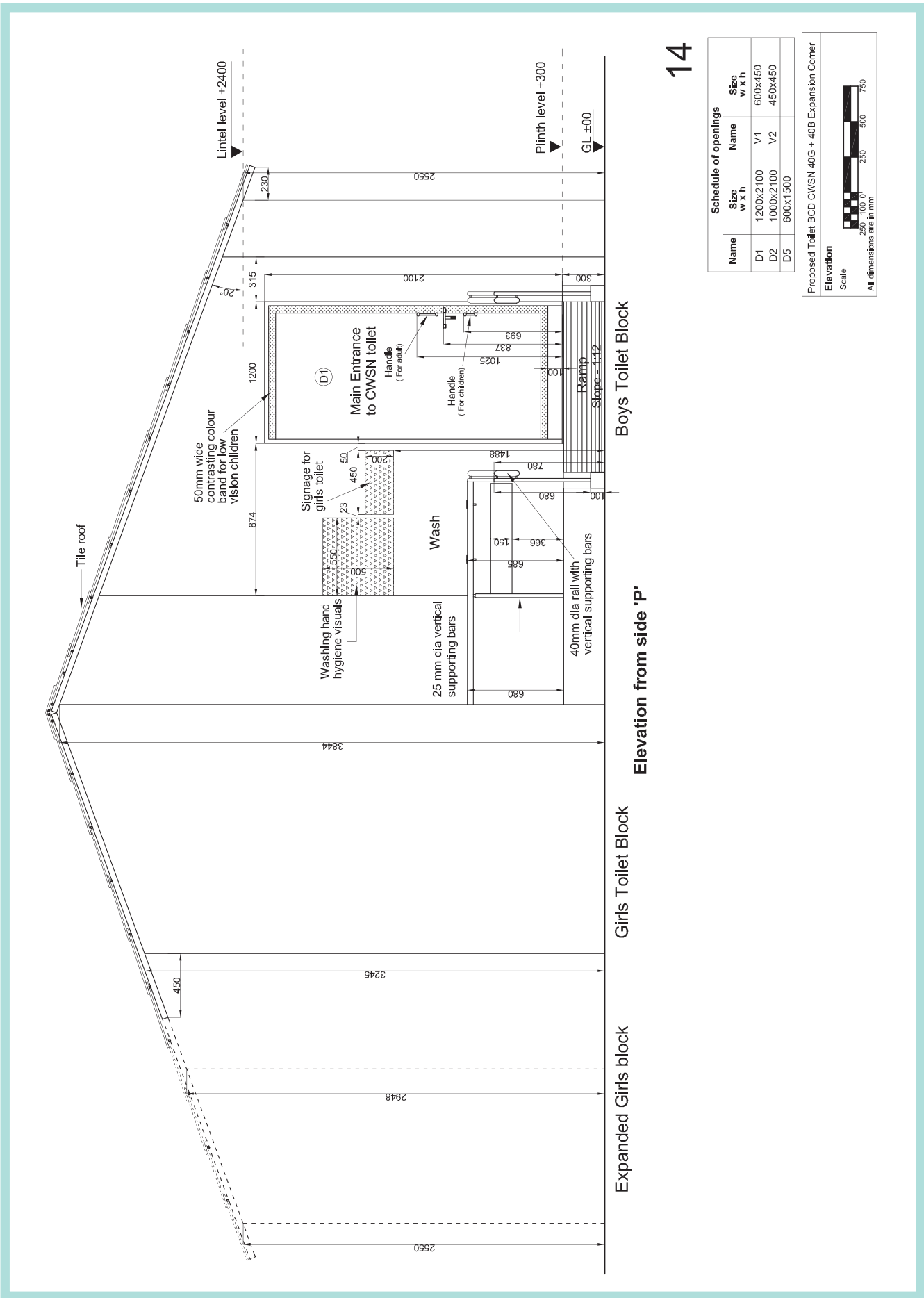

Bill of quantities – 14 ECD CWSN 40G + 40B Expansion Corner

ITEM	UNIT	Quantity	Rate	Indexed rate	Amount
1 Excavation					
a Foundation	cu.m	7.9875	30.00	35.4	282.76
b Leach and soak pit	cu.m	4.2076	30.00	35.4	148.95
c Ramp work	cu.m	1.6713	30.00	35.4	59.16
2 PCC					
a 1:3:6 PCC in foundation	cu.m	1.9969	1678.00	1980.04	3953.89
b 1:4:8 PCC in flooring	cu.m	0.8592	1503.60	1774.25	1524.51
c 1:4:8 PCC in Ramp	cu.m	1.0870	1503.60	1774.25	1928.61
3 Back-filling					
a Foundation	cu.m	2.4020	25.55	30.15	72.42
b Sand fill under floor	cu.m	1.5435	95.60	112.81	174.12
c Consolidated aggregate under floor	cu.m	1.5223		0.00	0.00
d Infill in soak pit	cu.m	1.8997	25.55	30.15	57.27
e Back fill in Ramp	cu.m	0.0591	25.55	30.15	1.78
4 Brick work					
a Brick work in foundation and plinth	cu.m	4.1384	1452.9	1714.42	7095.05
b Brickwork in Ramp	cu.m	0.8997	1452.90	1714.42	1542.47
c Honey comb brickwork in leach pit	sq.m	6.0540	216.45	255.41	1546.26
d 75mm thk masonry partition in superstructure	sq.m	2.1338	119.4	140.89	300.63
e 115mm thick masonry in superstructure	sq.m	61.4873	199.00	234.82	14438.45
f 230mm thick masonry in superstructure	cu.m	0.4844	1690.45	1994.73	966.25
g Brick work in steps	cu.m		1690.45	1994.73	0.00
h Dry brick work in paving	sq.m		80.85	95.40	0.00
5 RCC work					
a 1:2:4 RCC Plinth band	cu.m	0.4978	5209.75	6147.51	3060.05
b 1:2:4 RCC Lintel band (all types)	cu.m	0.3328	5209.75	6147.51	2045.89
c 1:2:4 PCC bed blocks for roof anchorage	cu.m	0.0198	2136.35	2520.89	50.01
6 Slab (Stone / precast RCC)					
a 125mm thk Slab under water tank	sq.m	0.6961	570.79	673.53	468.85
b 75mm thk Slab under hand wash areas (all)	sq.m	0.9082	342.47	404.11	367.02
c 50mm thk Partition shelves in storage	sq.m	0.4763	228.31	269.41	128.30
d 75mm thk Cover for water tank	sq.m	0.6961	342.47	404.11	281.30
e 75mm thk Cover for leach pit	sq.m	1.5386	342.47	404.11	621.77
7 Pointing and plastering					
a 1:4 pointing in exposed brick work	sq.m	46.0020	29.75	35.11	1614.90
b 1:6 cement sand plastering	sq.m	50.2635	39.90	47.08	2366.51
c 1:6 cement sand with waterproof plastering	sq.m	3.2700	32.73	38.62	126.29
8 Flooring					
a Cement concrete flooring	sq.m	9.3600	143.85	169.74	1588.79

cu.m – Cubic meter, sq.m – Square meter, m.m – Running meter

ITEM	UNIT	Quantity	Rate	Indexed rate	Amount
9 Tile work					
a Ceramic tile work in floor	sq.m	7.8441	504.10	594.84	4665.97
b Ceramic tile work in dado	sq.m	15.63375	504.10	594.84	9299.55
c Antiskid tiles in Ramp	sq.m	4.6956	406.15	479.26	2250.40
10 Sanitary fixtures					
a Rural squatting pan	number	2	350.00	413.00	826.00
b Girl's squatting urinal	number	2	300.00	354.00	708.00
11 Plumbing					
a GI pipe water supply line (internal) +3m external	m.m	10.398	78.65	92.81	965.01
b Taps	number	6	250.00	295.00	1770.00
c Waste water pipe for flushing	m.m	12.501	31.05	36.64	458.02
12 Sewage					
a Sewage line from squatting pan to first IC + 3m	m.m	6.349	111.60	131.69	836.09
b Waste drain line from urinal to first IC + 3m	m.m	8.4559	111.60	131.69	1113.54
13 Roof work					
a Roof area (sloping, with overhangs and overlaps)	sq.m	24.9759	700.00	700.00	17483.13
14 Doors					
a D1	number	2	500.00	590.00	1180.00
b D2	number	2	500.00	590.00	1180.00
c D3	number		500.00	590.00	0.00
d D4	number		500.00	590.00	0.00
e D5	number	2	500.00	590.00	1180.00
f Storage door shutter	number		500.00	590.00	0.00
15 Ventilators					
a V1	number	1	350.00	413.00	413.00
b V2	number	4	350.00	413.00	1652.00
c V3	number		350.00	413.00	
d V4	number		350.00	413.00	0.00
16 Incinerator					
a Metal / Masonry incinerator	number	1	1500.00	1500.00	1500.00
17 Painting work					
a Internal white washing	sq.m	50.2635	35.40	41.77	2099.61
b External wall painting	sq.m	46.002	30.00	35.40	1628.47
c Door and ventilator	sq.m	23.16	58	68.44	1585.07
18 Metal Work					
a Grab bars in toilets 40mm dia MS pipe	m.m	4.1448	32.10	37.88	157.00
b Rail in 40mm dia MS pipe in ramp	m.m	19.3711	32.10	37.88	733.74
c Vertical rail supports 25mm dia MS bars	m.m	8.15	32.10	37.88	308.71

Total Amount Rs. 100806
Total Area Sq.m 15.39
Cost per sqm 6550

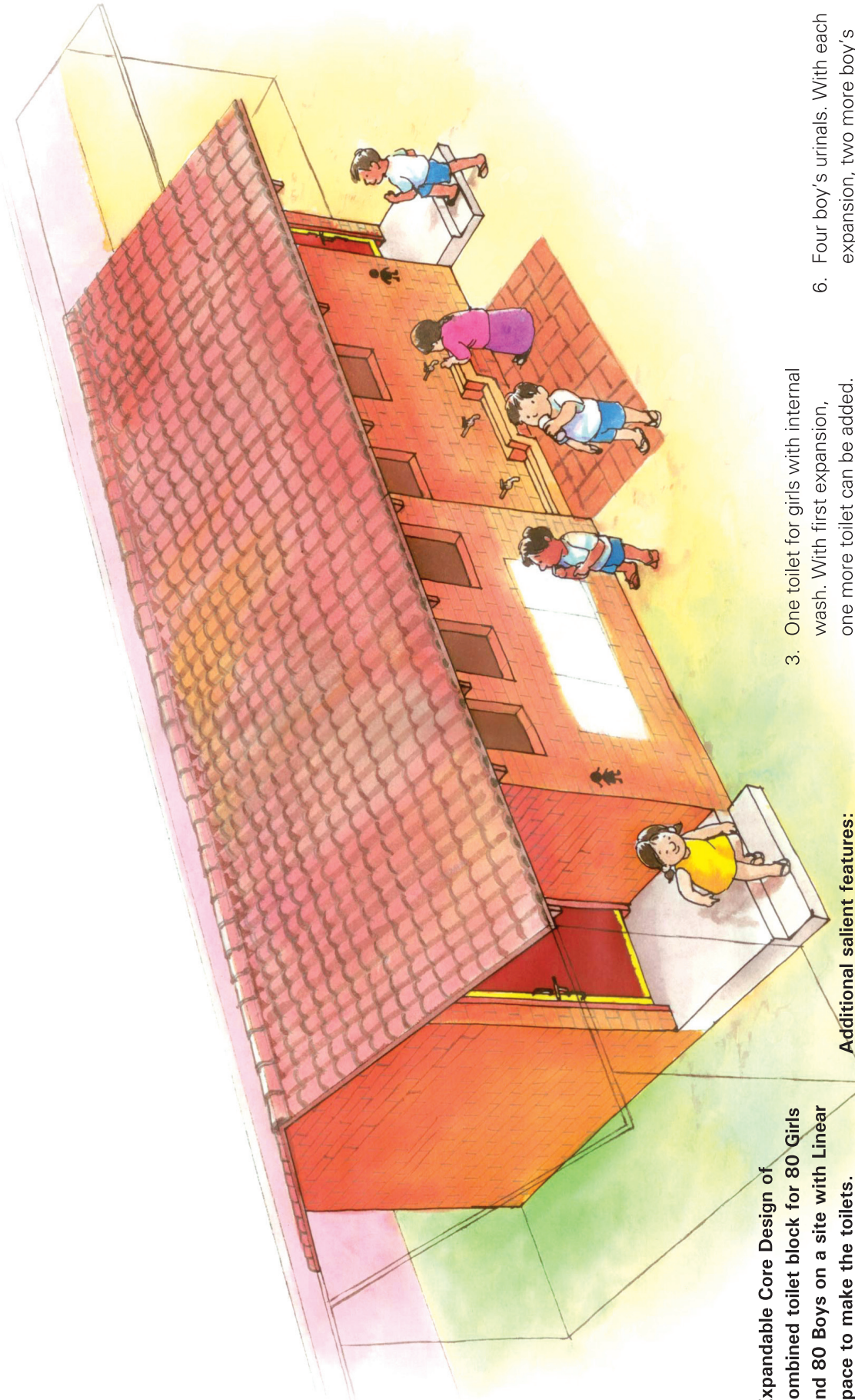

Expandable Core Design of combined toilet block for 80 Girls and 80 Boys on a site with Linear space to make the toilets.
 Suitable where there is scope for future expansion on sides. After first expansion this can serve total 120 Girls and 120 Boys.

Total Built-up Area: 14.95 sq.m
Indicative cost Rs 1,02,099

Additional salient features:

The design has:

1. Modular design for incremental growth in future. Expandable on sides.
2. Segregated entrances for girl's and boy's toilet blocks.

3. One toilet for girls with internal wash. With first expansion, one more toilet can be added.
4. Four girl's urinals. With each expansion, two more girl's urinals can be added.
5. One toilet for boys with internal wash. With first expansion, one more toilet can be added.
6. Four boy's urinals. With each expansion, two more boy's urinals can be added.
7. Thick common wall between boys and girl's toilet area.
8. Common external wash areas with provision for storage water tank.

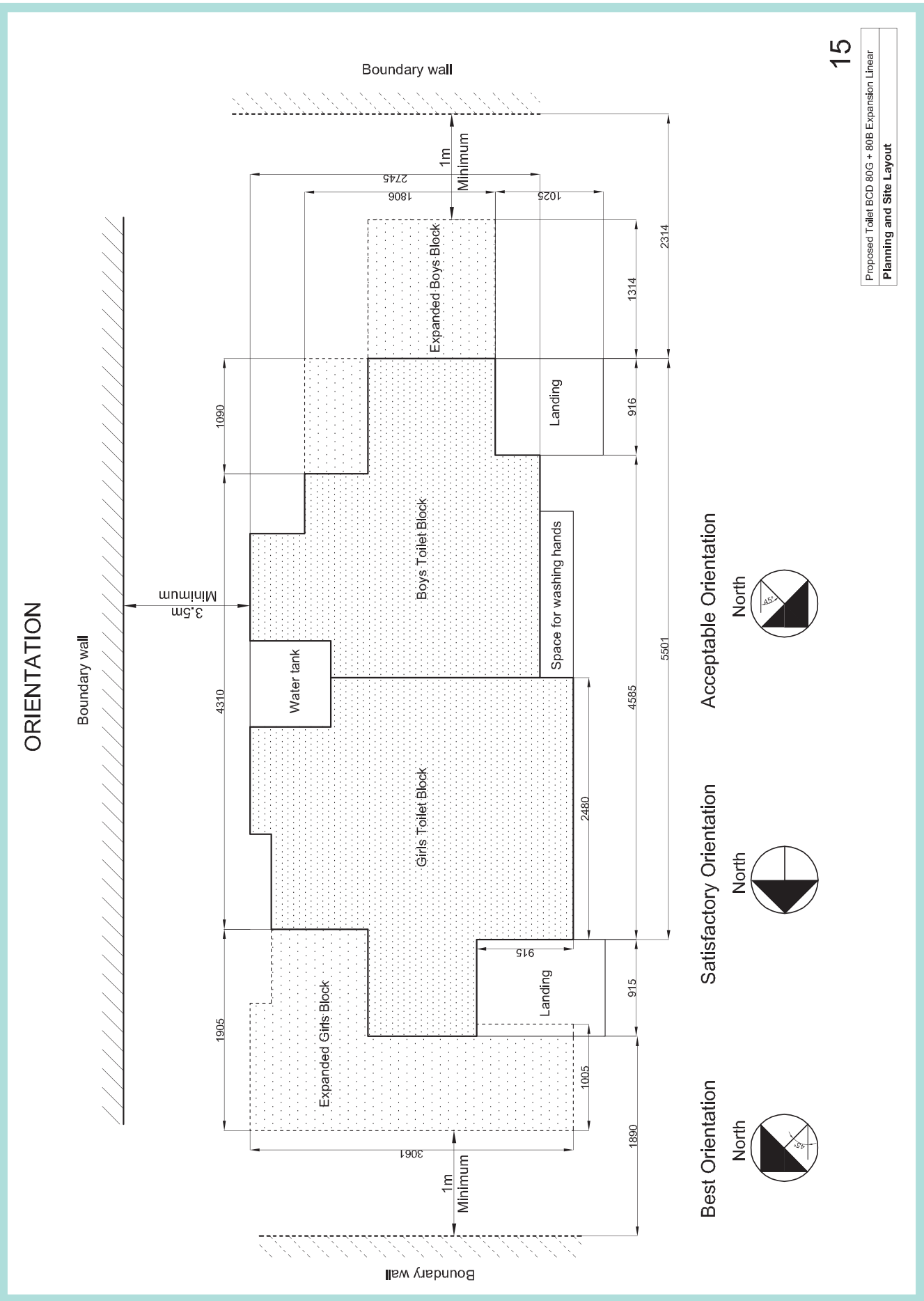

Plan – 15 ECD 80G +80B Expansion Linear

Notes

- This design is valid for brick strength not below 35kg/sq.cm.
- Foundation design is only indicative & may need review based on local site conditions.
- For masonry water tank, the foundation shall be in 230mm brick up to the base of the tank.
- Mortar 1:4 for 115mm thick masonry. No reinforcement bars in alternate courses.
- This design is valid for earth quake zone I, II & III only
- No water supply or waste water carrying pipe shall be concealed in the masonry wall. It shall be exposed and fixed with clips and not chased in masonry walls.
- In case the masonry specification is changed from that given here, maintain the internal clear dimensions and the layout and provide suitable redesigned foundation.
- Stopping roof overhang and its anchorage design may need review in cyclone prone regions.
- In case roof specifications are changed from that given here (e.g. flat roof in stone or RCC) provide suitable strengthening of masonry while maintaining all internal clearances in the layout design.
- Only one metallic / masonry incinerator to be put along the location indicated as ICN.
- Incinerator to be provided only with GI's toilet and to have chute from inside.
- Location of leach pits, soak pits, waste drainage pipes & inspection chamber is indicative only. Actual location to be decided based on site conditions.
- Minimum distance of leaching pit from building foundation to be 125cm in different soil types.
- Design of leach pit shown is for 80+80=160 children with its volume sufficient for catering approximately six months in different soil types. For higher capacity or longer duration, design will need review.

Key to symbols:

- Pipe carrying waste water from wash area to flush urinals.
- Open / Covered drain for waste from Urinal / Squatting pan.
- ▬ Masonry wall.
- Roof line

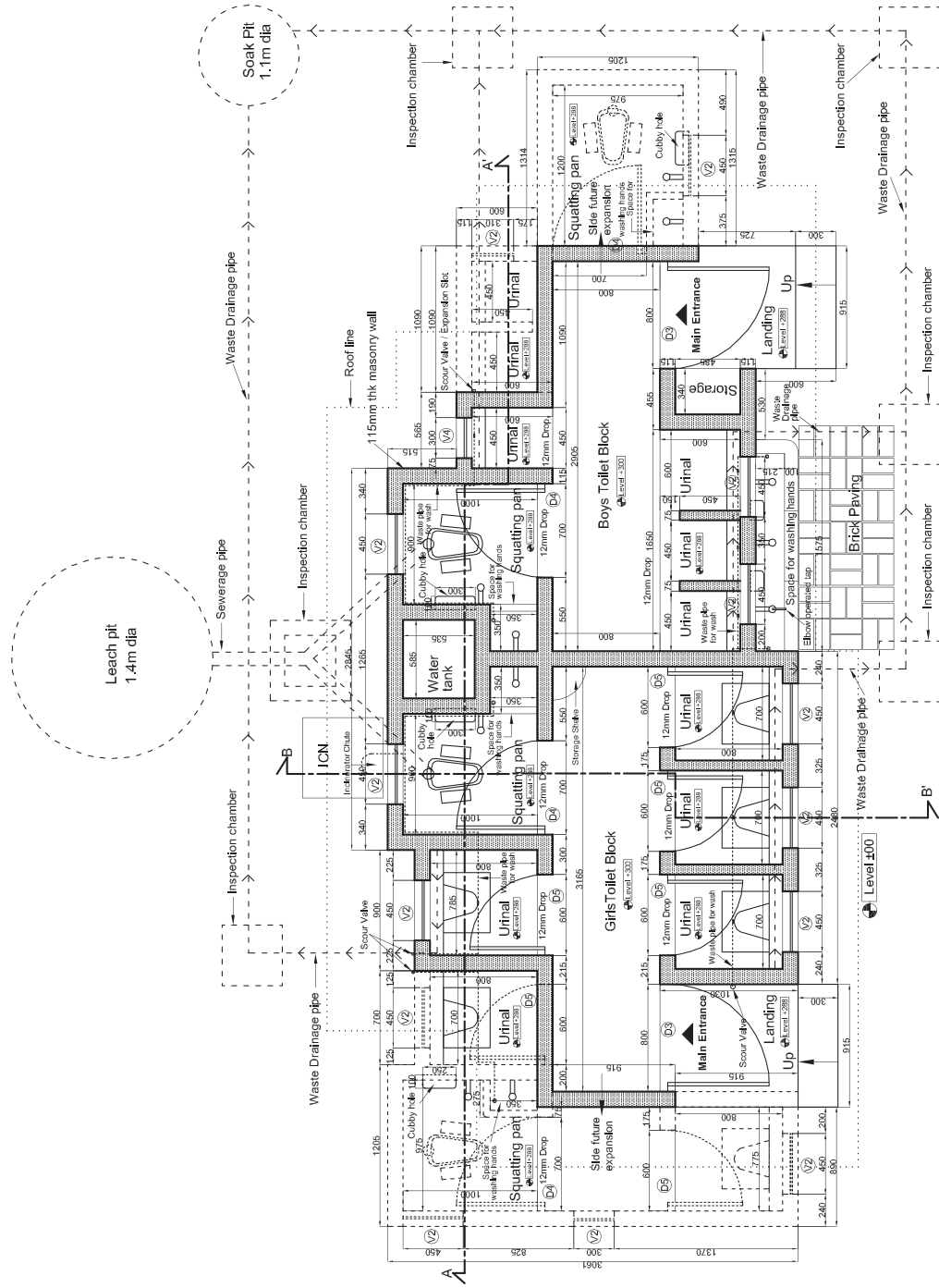

Front Side
Plan

Area calculation (Gross)		Schedule of openings	
Name	Area	Name	Size
Boys toilet block	5.96 sqm	D3	800x2100
Girls toilet block	2.24 sqm	D4	700x2100
Water tank	7.88 sqm	D5	600x1500
Wash area	0.62 sqm	V2	450x450
Landing+Steps	0.49 sqm	V4	300x450
Total	17.15 sqm		
After first expansion this toilet can serve 120G + 120B = 240 Children			
Total Overall Area	14.95 sqm		

15

Proposed Toilet BCD 80G + 80B Expansion Linear

Plan

Scale
20m 10m 5m 0m 5m 10m 20m

All dimensions are in mm

Section & Details – 15 ECD 80G + 80B Expansion Linear

Suggested brief specifications:

- Civil work**
1. Pre-construction chemical termite treatment as per need.
 2. PCC: 1:3:6 Cement; Coarse Sand; Coarse Aggregate in foundation.
 3. Foundation and Plinth in 1:4 cement mortar in brickwork.
 4. 75mm thick plinth band in 1:2:4 Reinforced Cement Concrete.
 5. Superstructure masonry in 1:4 cement mortar in 115 mm thick brick work.
 6. Pointing in 1:4 on exterior face.
 7. Plastering in 1:6 on interior face above dado level.
 8. All urinals and squatting pan area with ceramic tile floor and dado up to 750mm from finished floor.
 9. Use of waterproofing compound for plaster upto dado level and for flooring tile.
 10. All other flooring in cement concrete / stone tile as per availability. Slope in toilets & urinals floors is 1:50 or more.
 11. 150mm thick lintel band in 1:2:4 Reinforced Cement Concrete.
 12. Built-in water tank with masonry walls and lining of waterproof cement plaster.
 13. Sloping roof in MCR / Country tile / Mangalore tile with metal / timber under-structure.
 14. Roof under-structure to be tied to masonry/plinth band as per detail given.
 15. Door and ventilator frame in metal angle sections, painted with two coats of primer before installation.
 16. Door shutter in PVC/metal painted with two coats of primer and painted with enamel paint in light colour.

- Plumbing and Sanitary work**
17. All plumbing pipes in B class CI pipes with suitable elbow / tee / nipple / union / scour valves.
 18. All taps of best quality, locally available.
 19. All waste water carrying pipes in HDPE / PVC to flush urinals.
 20. All girths urinals squatting type in glazed ceramic type, white in colour.
 21. All squatting pan of rural pan type in glazed ceramic type, white in colour.
 22. All drainage and sewage pipes from Urinals / Squatting pan area in HDPE / PVC / CI / SW as per local availability.
 23. Leach pit with 115mm thick honeycomb brickwork in 1:4 cement sand mortar.

Schedule of openings	
Name	Size
D3	800x2100
D4	700x1500
D5	600x1500
V2	450x450
V4	300x450

15

Proposed Toilet BCD 80G + 80B Expansion Linear

Sections and Details
Scale
All dimensions are in mm

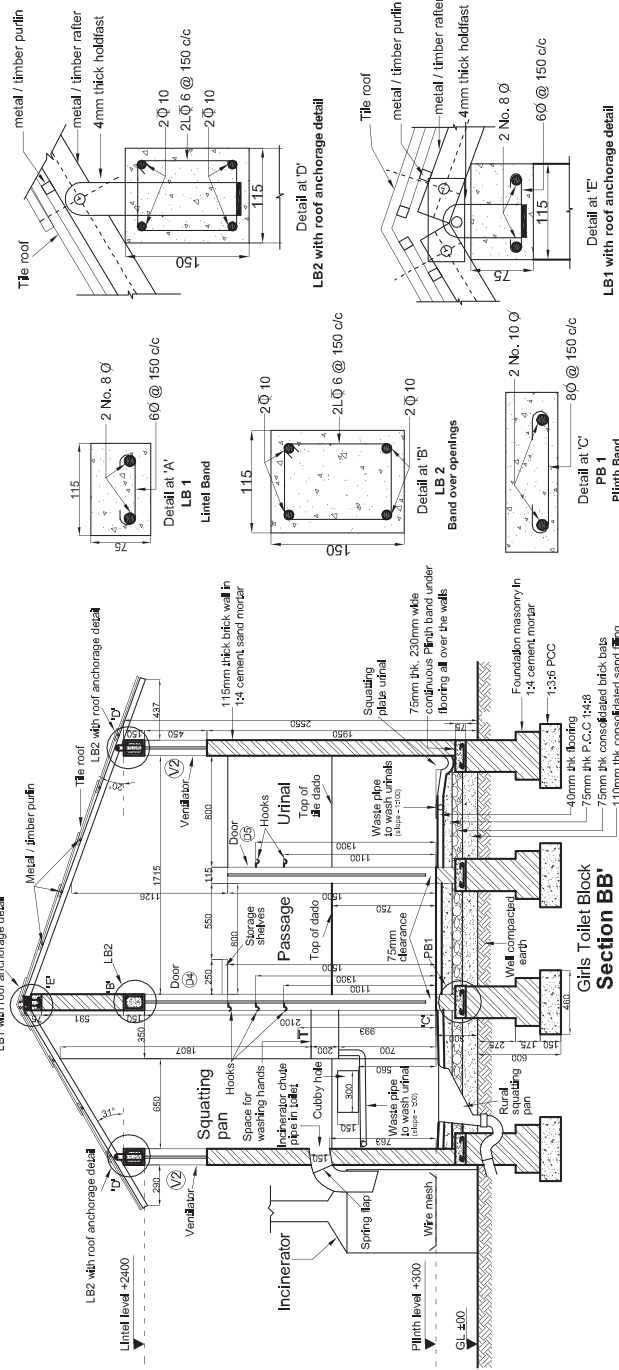
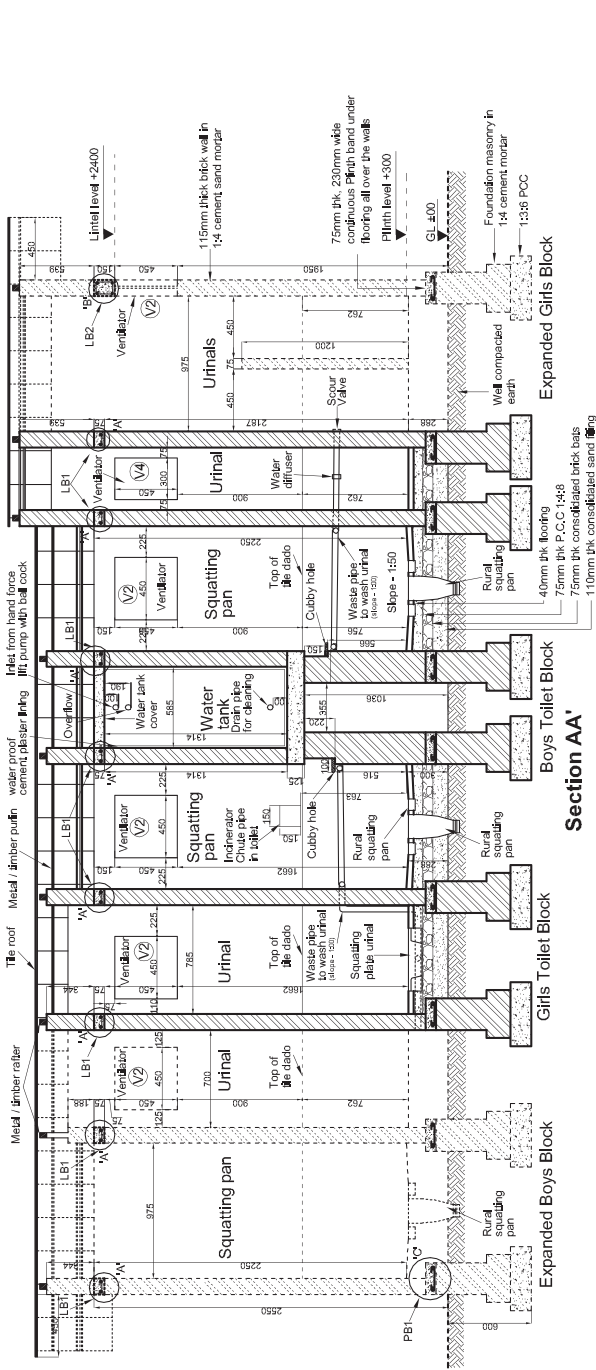

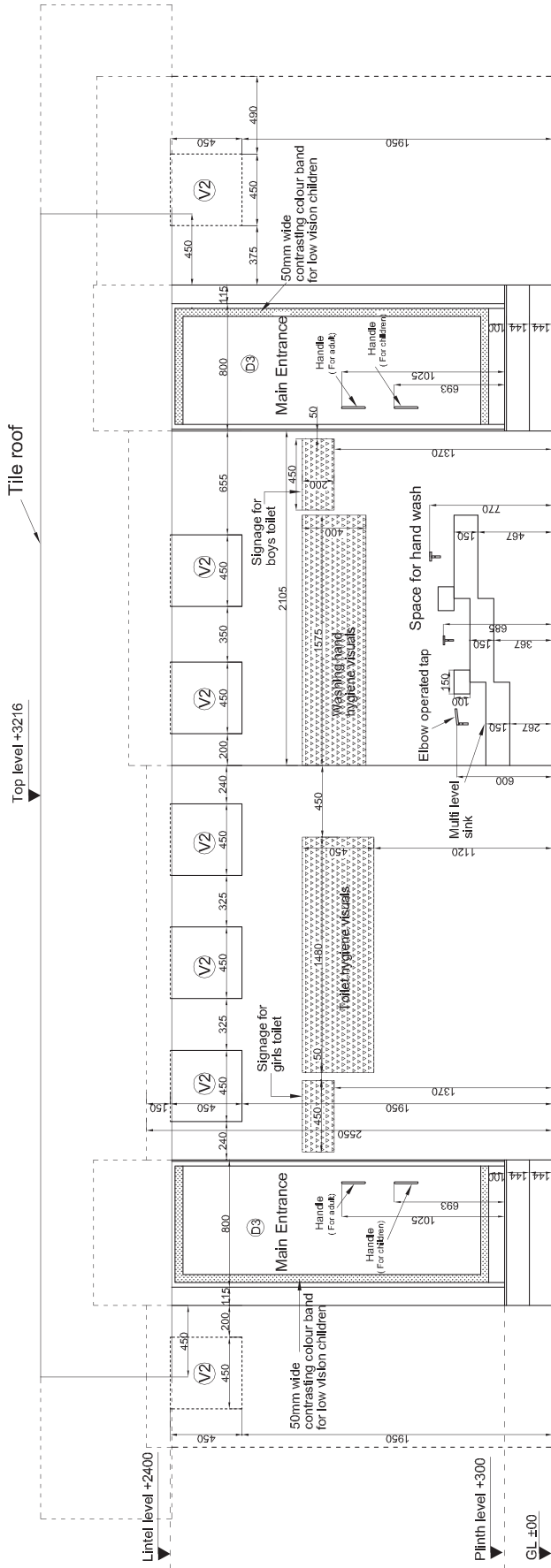

Expanded Girls Block Girls Toilet Block Boys Toilet Block Expanded Boys Block

Front Elevation

15

Schedule of openings			
Name	Size w x h	Name	Size w x h
D3	800x2100	V2	450x450
D4	700x2100	V4	300x450
D5	600x1500		

Proposed Toilet BCD 80G + 80B Expansion Linear

Elevation

Scale: 2000 : 100 @ 250 650 750

All dimensions are in mm

Bill of quantities – 15 ECD 80G +80B Expansion Linear

ITEM	UNIT	Quantity	Rate	Indexed rate	Amount
1 Excavation					
a Foundation	cu.m	8.7269	30.00	35.4	308.93
b Leach and soak pit	cu.m	4.2076	30.00	35.4	148.95
c Ramp work	cu.m		30.00	35.4	
2 PCC					
a 1:3:6 PCC in foundation	cu.m	2.1121	1678.00	1980.04	4181.95
b 1:4:8 PCC in flooring	cu.m	1.0830	1503.60	1774.25	1921.51
c 1:4:8 PCC in Ramp	cu.m		1503.60	1774.25	
3 Back-filling					
a Foundation	cu.m	2.5406	25.55	30.15	76.60
b Sand fill under floor	cu.m	0.8796	95.60	112.81	99.22
c Consolidated aggregate under floor	cu.m	0.8043		0.00	0.00
d Infill in soak pit	cu.m	1.8997	25.55	30.15	57.27
e Back fill in Ramp	cu.m		25.55	30.15	
4 Brick work					
a Brickwork in foundation and plinth	cu.m	4.3772	1452.9	1714.42	7504.30
b Brickwork in Ramp	cu.m		1452.90	1714.42	
c Honey comb brickwork in leach pit	sq.m	6.0540	216.45	255.41	1546.26
d 75mm thk masonry partition in superstructure	sq.m	3.9630	119.4	140.89	558.35
e 115mm thick masonry in superstructure	sq.m	65.4436	199.00	234.82	15367.47
f 230mm thick masonry in superstructure	cu.m	0.4480	1690.45	1994.73	893.64
g Brick work in steps	cu.m	0.5606	1690.45	1994.73	1118.25
h Dry brick work in paving	sq.m	1.1783	80.85	95.40	112.41
5 RCC work					
a 1:2:4 RCC Plinth band	cu.m	0.5265	5209.75	6147.51	3236.56
b 1:2:4 RCC Lintel band (all types)	cu.m	0.3662	5209.75	6147.51	2251.22
c 1:2:4 PCC bed blocks for roof anchorage	cu.m	0.0238	2136.35	2520.89	60.01
6 Slab (Stone / precast RCC)					
a 125mm thk Slab under water tank	sq.m	0.6234	570.79	673.53	419.88
b 75mm thk Slab under hand wash areas (all)	sq.m	0.9531	342.47	404.11	385.16
c 50mm thk Partition shelves in storage	sq.m	1.4040	228.31	269.41	378.25
d 75mm thk Cover for water tank	sq.m	0.6234	342.47	404.11	251.93
e 75mm thk Cover for leach pit	sq.m	1.5386	342.47	404.11	621.77
7 Pointing and plastering					
a 1:4 pointing in exposed brick work	sq.m	43.7940	29.75	35.11	1537.39
b 1:6 cement sand plastering	sq.m	56.2298	39.90	47.08	2647.41
c 1:6 cement sand with waterproof plastering	sq.m	5.9663	32.73	38.62	230.42
8 Flooring					
a Cement concrete flooring	sq.m	7.0993	143.85	169.74	1205.06

cu.m – Cubic meter, sq.m – Square meter, m.m – Running meter

ITEM	UNIT	Quantity	Rate	Indexed rate	Amount
9 Tile work					
a Ceramic tile work in floor	sq.m	5.5455	504.10	594.84	3298.67
b Ceramic tile work in dado	sq.m	14.9025	504.10	594.84	8864.57
c Antiskid tiles in Ramp	sq.m		406.15	479.26	
10 Sanitary fixtures					
a Rural squatting pan	number	2	350.00	413.00	826.00
b Girl's squatting urinal	number	4	300.00	354.00	1416.00
11 Plumbing					
a GI pipe water supply line (internal) +3m external	m.m	7.7091	78.65	92.81	715.46
b Taps	number	7	250.00	295.00	2065.00
c Waste water pipe for flushing	m.m	10.8815	31.05	36.64	398.69
12 Sewage					
a Sewage line from squatting pan to first IC + 3m	m.m	5.4495	111.60	131.69	717.63
b Waste drain line from urinal to first IC + 3m	m.m	9.3179	111.60	131.69	1227.06
13 Roof work					
a Roof area (sloping, with overhangs and overlaps)	sq.m	27.7705	700.00	700.00	19439.35
14 Doors					
a D1	number		500.00	590.00	
b D2	number		500.00	590.00	
c D3	number	2	500.00	590.00	1180.00
d D4	number	2	500.00	590.00	1180.00
e D5	number	4	500.00	590.00	2360.00
f Storage door shutter	number	1	500.00	590.00	590.00
15 Ventilators					
a V1	number		350.00	413.00	0.00
b V2	number	8	350.00	413.00	3304.00
c V3	number		350.00	413.00	
d V4	number	1	350.00	413.00	413.00
16 Incinerator					
a Metal / Masonry incinerator	number	1	1500.00	1500.00	1500.00
17 Painting work					
a Internal white washing	sq.m	56.2298	35.40	41.77	2348.83
b External wall painting	sq.m	43.794	30.00	35.40	1550.31
c Door and ventilator	sq.m	23.1555	58	68.44	1584.76
18 Metal Work					
a Grab bars in toilets 40mm dia MS pipe	m.m		32.10	37.88	
b Rail in 40mm dia MS pipe in ramp	m.m		32.10	37.88	
c Vertical rail supports 25mm dia MS bars	m.m		32.10	37.88	

Total Amount Rs. 102099
Total Area Sq.m 14.95
Cost per sqm 6829

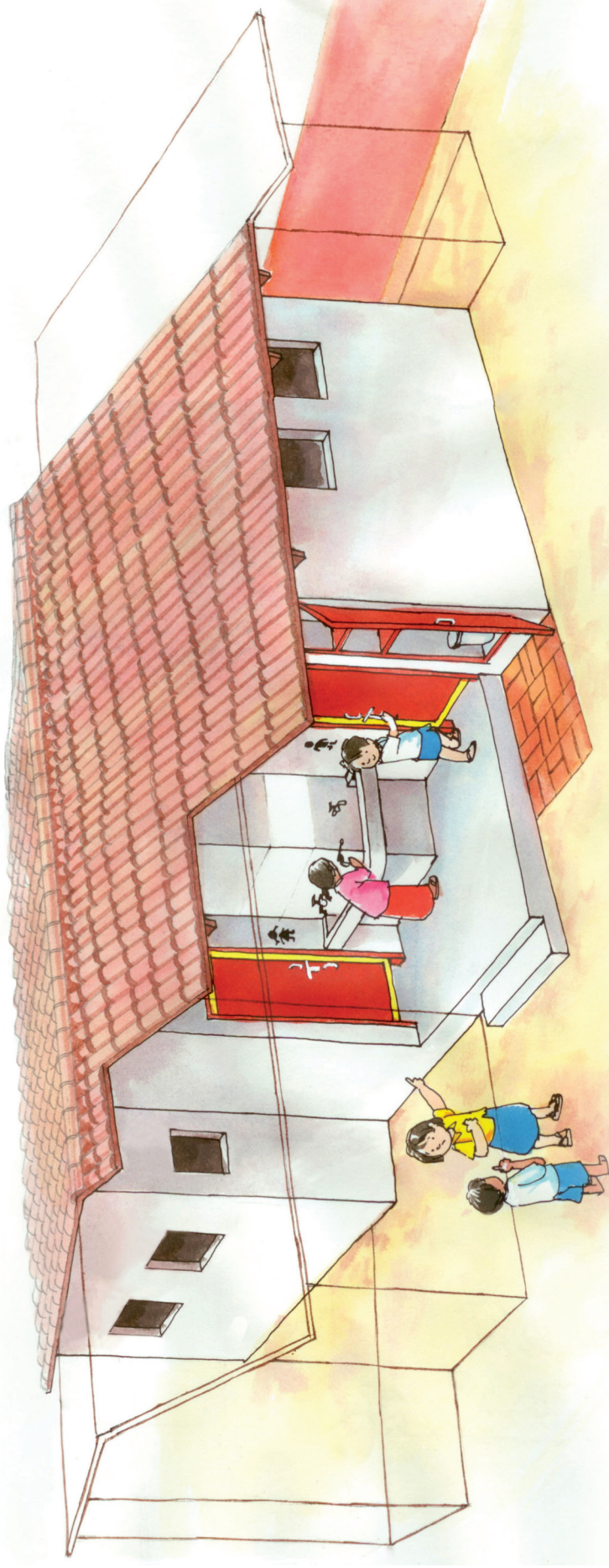

Expandable Core Design of combined toilet block for 80 Girls and 80 Boys on a site with 'L' shaped space to make the toilets. Suitable where there is scope for future expansion towards sides and rear. After first expansion this can serve total 120 Girls and 120 Boys.

Total Built-up Area: 13.53 sq.m
Indicative cost Rs 99,072

Additional salient features:

The design has:

1. Modular design for incremental growth in future. Expandable on sides.
2. Segregated entrances for girl's and boy's toilet blocks.
3. One toilet for girls with internal wash. With first expansion, one more toilet can be added.
4. Four girl's urinals. With each expansion, two more girl's urinals can be added.
5. One toilet for boys with internal wash. With first expansion, one more toilet can be added.
6. Four boy's urinals. With each expansion, two more boy's urinals can be added.
7. Thick common wall between boys and girl's toilet area.
8. Common external wash areas with provision for storage water tank.

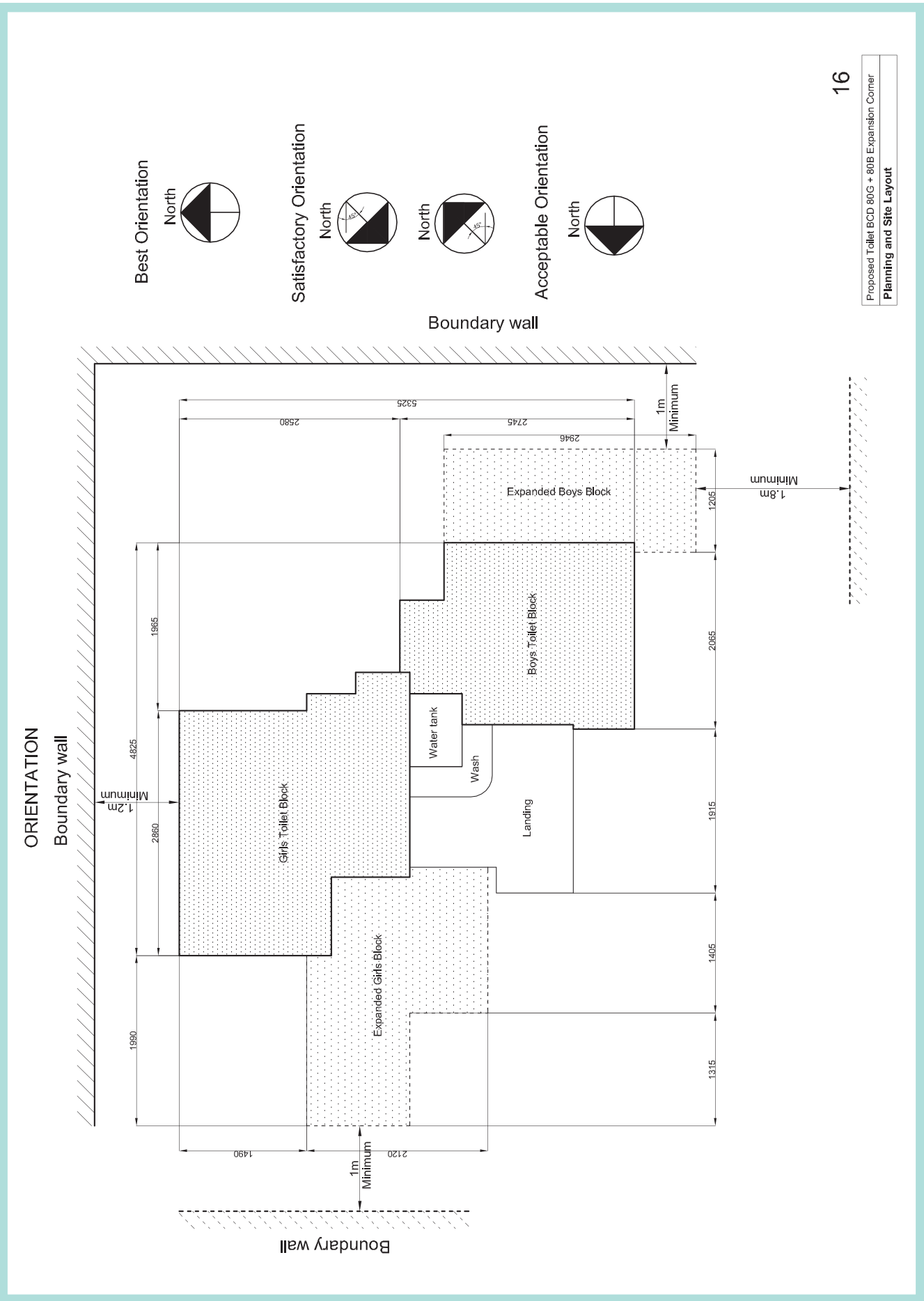

Plan – 16 ECD 80G + 80B Expansion Corner

Notes

- This design is valid for brick strength not below 35kg/sq.cm.
- Foundation design is only indicative & may need review based on local site conditions.
- For masonry water tank, the foundation shall be in 230mm brick up to the base of the tank.
- Mortar 1:4 for 115mm thick masonry. No reinforcement bars in alternate courses.
- This design is valid for earth quake zone I, II & III only
- No water supply or waste water carrying pipe shall be concealed in the masonry wall. It shall be exposed and fixed with clips and not chased in masonry walls.
- In case the masonry specification is changed from that given here, maintain the internal clear dimensions & the layout and provide suitable redesigned foundation.
- Stopping roof overhang and its anchorage design may need review in cyclone prone regions.
- In case roof specifications are changed from that given here (e.g. flat roof in stone or RCC provide suitable strengthening of masonry while maintaining all internal clearances in the layout design.
- Only one metallic / masonry incinerator to be put along the location indicated as ICN.
- Incinerator to be provided only with Girls toilet and to have chute from inside.
- Location of leach pits, soak pits, waste drainage pipes & inspection chamber is indicative only. Actual location to be decided based on site conditions.
- Minimum distance of leaching pit from building foundation to be 125cm in different soil types.
- Design of leach pit shown is for 80+80=160 children with its volume sufficient for catering approximately six months in different soil types. For higher capacity or longer duration, design will need review.

Key to symbols:

- Pipe carrying waste water from wash area to flush urinals.
- Open / Covered drain for waste from Urinal / Squatting pan.
- Masonry wall.
- Roof line

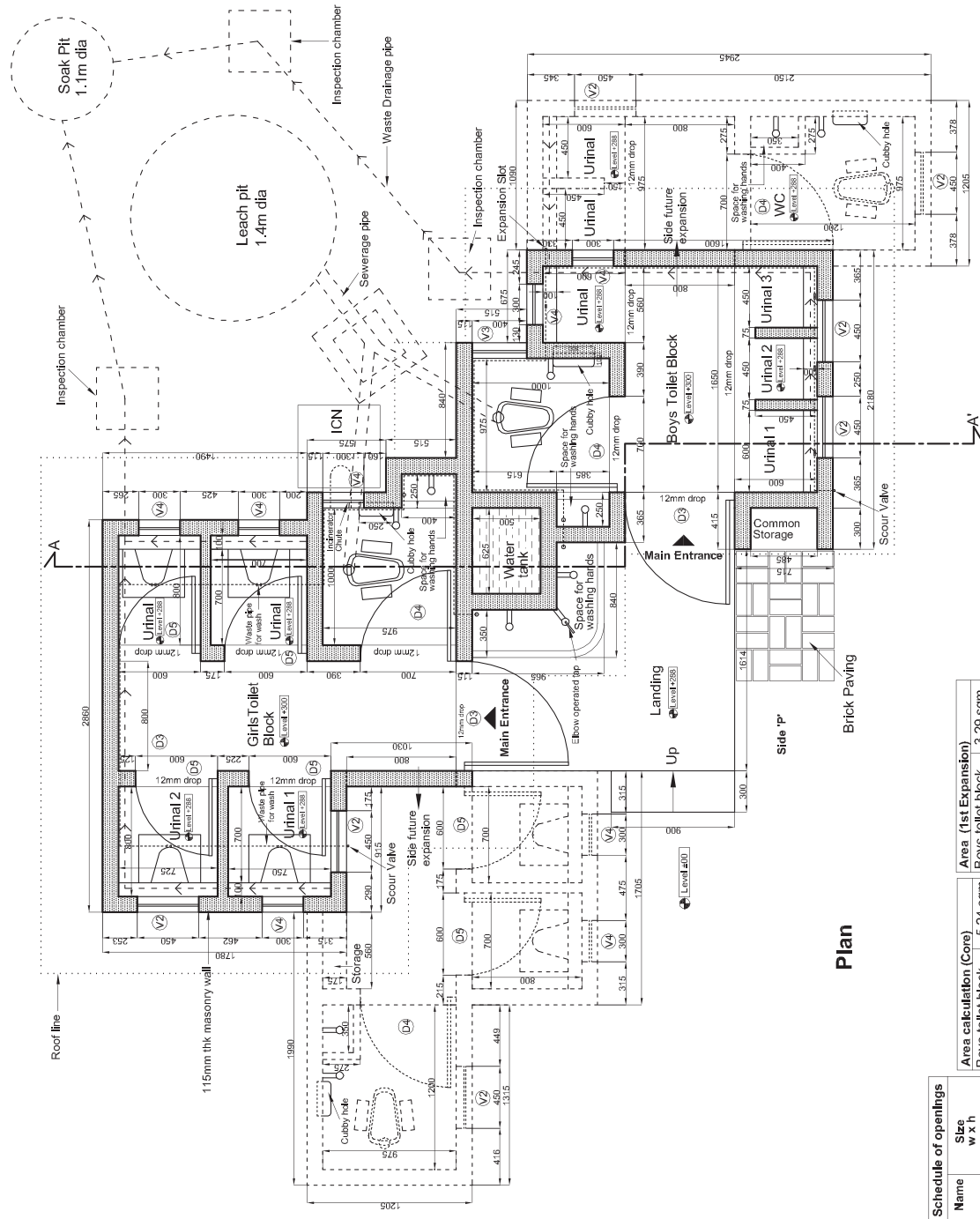

Plan

Schedule of openings

Name	Size w x h	Area calculation (Core)	Area (1st Expansion)
D3	800x2100	5.24 sqm	Boys toilet block 3.29 sqm
D4	700x2100	7.27 sqm	Girls toilet block 4.79 sqm
D5	600x1500	0.53 sqm	Girls toilet block 8.08 sqm
V2	450x450	0.49 sqm	
V3	400x450	2.63 sqm	After first expansion this toilet can serve 120G + 120B = 240 Children
V4	300x450	13.53 sqm	

Area calculation (Core)	Area (1st Expansion)
Boys toilet block	3.29 sqm
Girls toilet block	4.79 sqm
Total	8.08 sqm

After first expansion this toilet can serve 120G + 120B = 240 Children

16

Proposed Toilet BCD 80G + 80B Expansion Corner

Plan
Scale: 1:100
All dimensions are in mm

Section & Details – 16 ECD 80G + 80B Expansion Corner

Suggested brief specifications:

- Civil work**
- 1.Pre-construction chemical termite treatment as per need.
 - 2.PCC 1:3:6 Cement: Coarse Sand: Coarse Aggregate in foundation.
 - 3.Foundation and Plinth in 1:4 cement mortar in brickwork.
 - 4.75mm thick plinth band in 1:2:4 Reinforced Cement Concrete.
 - 5.Superstructure masonry in 1:4 cement mortar in 115 mm thick brick work.
 - 6.Plastering in 1:4 on exterior face.
 - 7.Plastering in 1:6 on interior face above dado level.
 - 8.All urinals and squatting pan area with ceramic tile floor and dado up to 750mm from finished floor.
 - 9.Use of waterproofing compound for plaster upto dado level and for fixing tile.
 - 10.All other flooring in cement concrete / stone tile as per availability. Slope in toilets & urinals floor is 1:50 or more.
 - 11.150mm thick Lintel band in 1:2:4 Reinforced Cement Concrete.
 - 12.Built-in water tank with masonry walls and lining of waterproof cement plaster.
 - 13.Sloping roof in MCR / Country tile / Mangalore tile with metal / timber under-structure.
 - 14.Roof under-structure to be tied to masonry/lintel band as per detail given.
 - 15.Door and ventilator frame in metal angle sections, painted with two coat of primer before installation.
 - 16.Door shutter in PVC/metal painted with two coats of primer and painted with enamel paint in light colour.

Plumbing and Sanitary work

- 17.All plumbing pipes in B class GI pipes with suitable elbow / tee / nipple / union / scour valves.
- 18.All taps of best quality, locally available.
- 19.All waste water carrying pipes in HDPE / PVC to flush urinals.
- 20.All girls urinals squatting type in glazed ceramic type, white in colour.
- 21.All squatting pan of rural pan type in glazed ceramic type, white in colour
- 22.All drainage and sewage pipes from Urinals / Squatting pan area in HDPE / PVC / GI / SW as per local availability.
- 23.Leach pit with 115mm thick honeycomb brickwork in 1:4 cement sand mortar

Name	Size w x h
D3	800x2100
D4	700x2100
D5	600x1500
V2	450x450
V3	400x450
V4	300x450

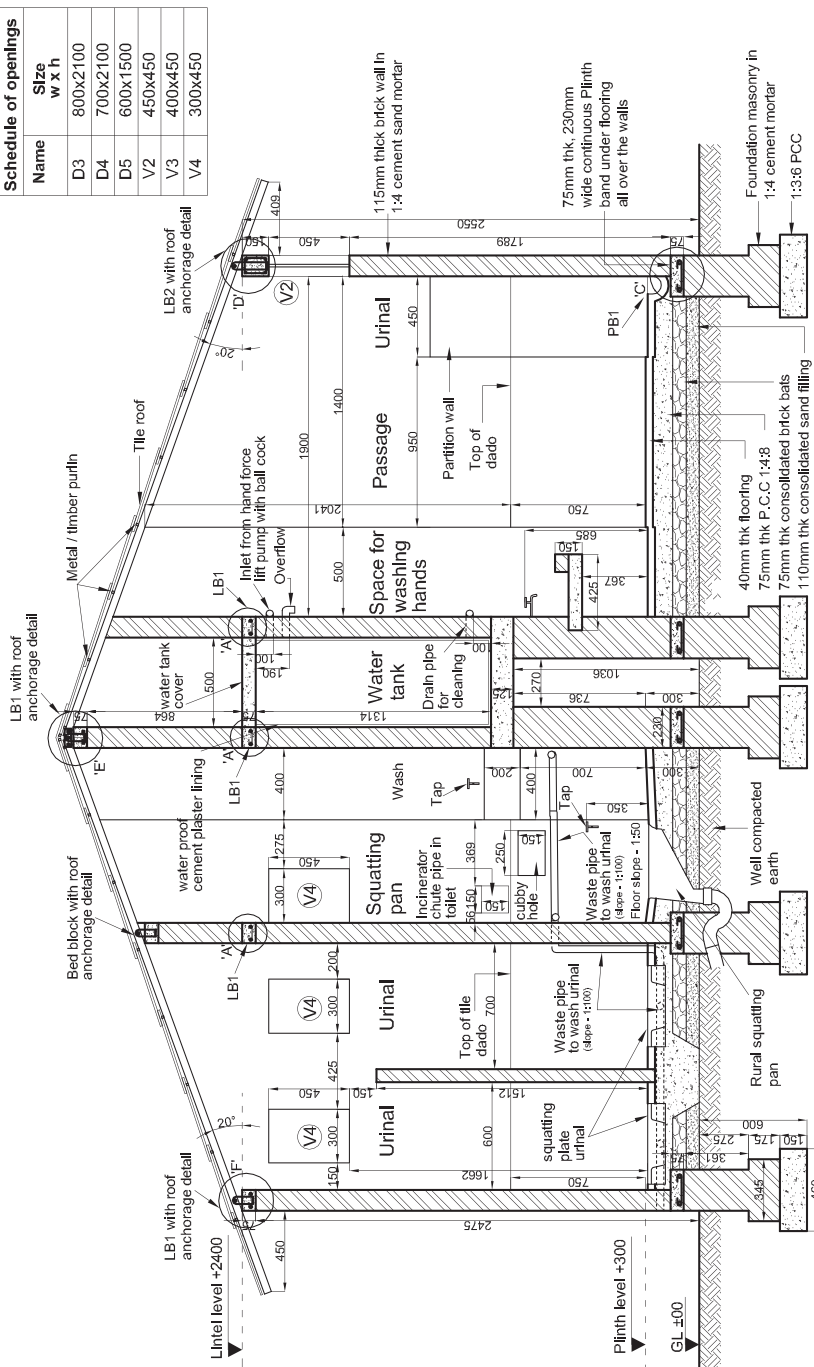

Boys Toilet Block

Section AA'

Girls Toilet Block

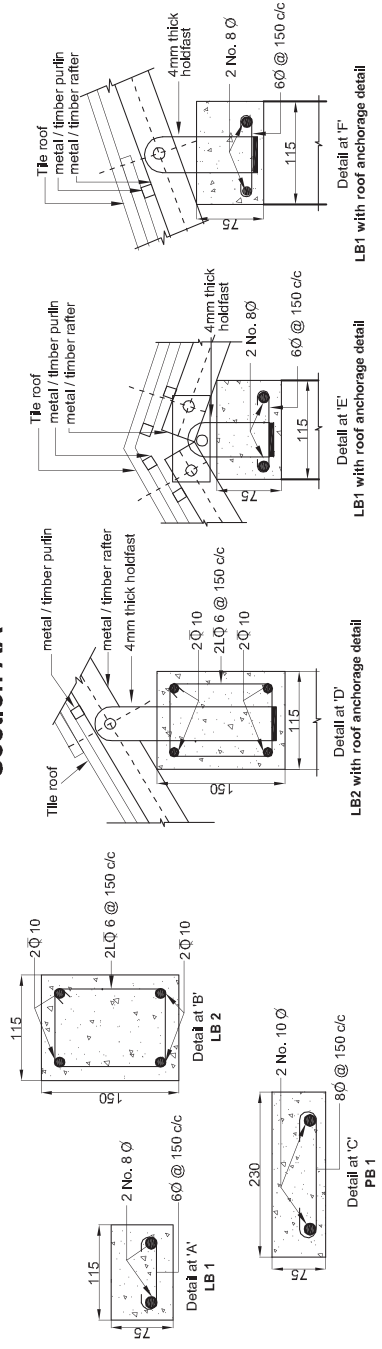

Proposed Toilet BCD 80G + 80B Expansion Corner

Section and Details

Scale: 1:50, 1:100, 1:200, 1:500, 1:750

All dimensions are in mm

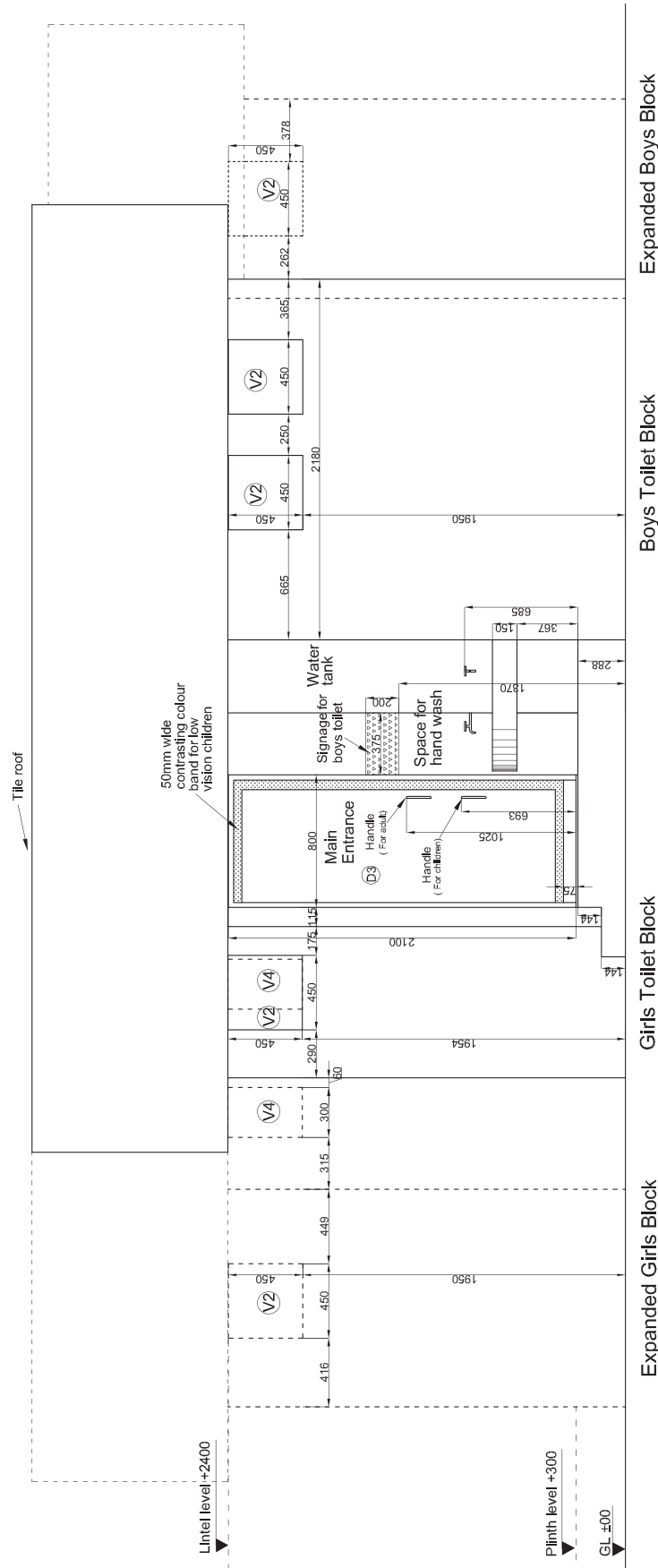

Elevation from Side 'P'

16

Schedule of openings		
Name	W x H	Size W x H
D4	700x2100	450x450
D5	600x1500	400x450
		300x450

Proposed Toilet BCD 80G + 80B Expansion Corner

Elevation

Scale
250 100 0
250 500 750

All dimensions are in mm

Bill of quantities – 16 ECD 80G + 80B Expansion Corner

ITEM	UNIT	Quantity	Rate	Indexed rate	Amount
1 Excavation					
a Foundation	cu.m	8.4619	30.00	35.4	299.55
b Leach and soak pit	cu.m	4.2076	30.00	35.4	148.95
c Ramp work	cu.m		30.00	35.4	
2 PCC					
a 1:3:6 PCC in foundation	cu.m	2.0189	1678.00	1980.04	3997.58
b 1:4:8 PCC in flooring	cu.m	1.0606	1503.60	1774.25	1881.84
c 1:4:8 PCC in Ramp	cu.m		1503.60	1774.25	
3 Back-filling					
a Foundation	cu.m	2.4286	25.55	30.15	73.22
b Sand fill under floor	cu.m	0.7138	95.60	112.81	80.52
c Consolidated aggregate under floor	cu.m	0.6827		0.00	0.00
d Infill in soak pit	cu.m	1.8997	25.55	30.15	57.27
e Back fill in Ramp	cu.m		25.55	30.15	
4 Brick work					
a Brickwork in foundation and plinth	cu.m	4.1842	1452.9	1714.42	7173.45
b Brickwork in Ramp	cu.m		1452.90	1714.42	
c Honey comb brickwork in leach pit	sq.m	6.0540	216.45	255.41	1546.26
d 75mm thk masonry partition in superstructure	sq.m	3.9630	119.4	140.89	558.35
e 115mm thick masonry in superstructure	sq.m	61.6375	199.00	234.82	14473.72
f 230mm thick masonry in superstructure	cu.m	0.4500	1690.45	1994.73	897.63
g Brick work in steps	cu.m	0.9808	1690.45	1994.73	1956.43
h Dry brick work in paving	sq.m	0.6964	80.85	95.40	66.44
5 RCC work					
a 1:2:4 RCC Plinth band	cu.m	0.5033	5209.75	6147.51	3093.87
b 1:2:4 RCC Lintel band (all types)	cu.m	0.3503	5209.75	6147.51	2153.47
c 1:2:4 PCC bed blocks for roof anchorage	cu.m	0.0258	2136.35	2520.89	65.01
6 Slab (Stone / precast RCC)					
a 125mm thk Slab under water tank	sq.m	0.6242	570.79	673.53	420.39
b 75mm thk Slab under hand wash areas (all)	sq.m	0.9175	342.47	404.11	370.78
c 50mm thk Partition shelves in storage	sq.m	0.6143	228.31	269.41	165.48
d 75mm thk Cover for water tank	sq.m	0.6242	342.47	404.11	252.23
e 75mm thk Cover for leach pit	sq.m	1.5386	342.47	404.11	621.77
7 Pointing and plastering					
a 1:4 pointing in exposed brick work	sq.m	46.1172	29.75	35.11	1618.94
b 1:6 cement sand plastering	sq.m	52.3900	39.90	47.08	2466.63
c 1:6 cement sand with waterproof plastering	sq.m	3.0375	32.73	38.62	117.31
8 Flooring					
a Cement concrete flooring	sq.m	6.9991	143.85	169.74	1188.05

cu.m – Cubic meter, sq.m – Square meter, m.m – Running meter

ITEM	UNIT	Quantity	Rate	Indexed rate	Amount
9 Tile work					
a Ceramic tile work in floor	sq.m	5.6247	504.10	594.84	3345.79
b Ceramic tile work in dado	sq.m	17.595	504.10	594.84	10466.17
c Antiskid tiles in Ramp	sq.m		406.15	479.26	
10 Sanitary fixtures					
a Rural squatting pan	number	2	350.00	413.00	826.00
b Girl's squatting urinal	number	4	300.00	354.00	1416.00
11 Plumbing					
a GI pipe water supply line (internal) +3m external	m.m	7.128	78.65	92.81	661.53
b Taps	number	7	250.00	295.00	2065.00
c Waste water pipe for flushing	m.m	15.4618	31.05	36.64	566.50
12 Sewage					
a Sewage line from squatting pan to first IC + 3m	m.m	5.6548	111.60	131.69	744.67
b Waste drain line from urinal to first IC + 3m	m.m	4.3533	111.60	131.69	573.28
13 Roof work					
a Roof area (sloping, with overhangs and overlaps)	sq.m	23.9209	700.00	700.00	16744.63
14 Doors					
a D1	number		500.00	590.00	
b D2	number		500.00	590.00	
c D3	number	2	500.00	590.00	1180.00
d D4	number	2	500.00	590.00	1180.00
e D5	number	4	500.00	590.00	2360.00
f Storage door shutter	number	1	500.00	590.00	590.00
15 Ventilators					
a V1	number		350.00	413.00	0.00
b V2	number	4	350.00	413.00	1652.00
c V3	number	1	350.00	413.00	413.00
d V4	number	4	350.00	413.00	1652.00
16 Incinerator					
a Metal / Masonry incinerator	number	1	1500.00	1500.00	1500.00
17 Painting work					
a Internal white washing	sq.m	52.39	35.40	41.77	2188.44
b External wall painting	sq.m	46.1172	30.00	35.40	1632.55
c Door and ventilator	sq.m	22.9305	58	68.44	1569.36
18 Metal Work					
a Grab bars in toilets 40mm dia MS pipe	m.m		32.10	37.88	
b Rail in 40mm dia MS pipe in ramp	m.m		32.10	37.88	
c Vertical rail supports 25mm dia MS bars	m.m		32.10	37.88	

Total Amount Rs. 99072
Total Area Sq.m 13.53
Cost per sqm 7322

Section 5

Good Designs from States

In this section designs from five states that were evaluated in detail have been presented. The original designs have been modified to bring them closer to the various issues of essential and optional components, norms and guiding design principles described earlier. These are from the states of:

1. Andhra Pradesh
2. Gujarat
3. Jharkhand
4. Madhya Pradesh
5. Orissa

Some of the common salient features are as follows:

1. All toilets are designed for inclusiveness. Each block has integrated but a separate toilet for normal as well as for CWSN.
2. Common accessibility ramp has been provided with rails and other details

3. Waste water from the hand wash facility is used for flushing in the urinals.
4. Use of natural ventilation and lighting for solar passive drying and hygiene
5. Toilet maintenance / upkeep storage provision has been provided.
6. Scope for future expansion in different directions has been duly considered – since each school site may offer a unique situation for expansion. Hence expansion in more than one side may be shown in the design.

For each design, note the following:

1. Possible options for location of incinerator are shown as ICN for the Girl's toilet block.
2. Best orientation of the toilet block is suggested in the plan.

Good Design - Andhra Pradesh

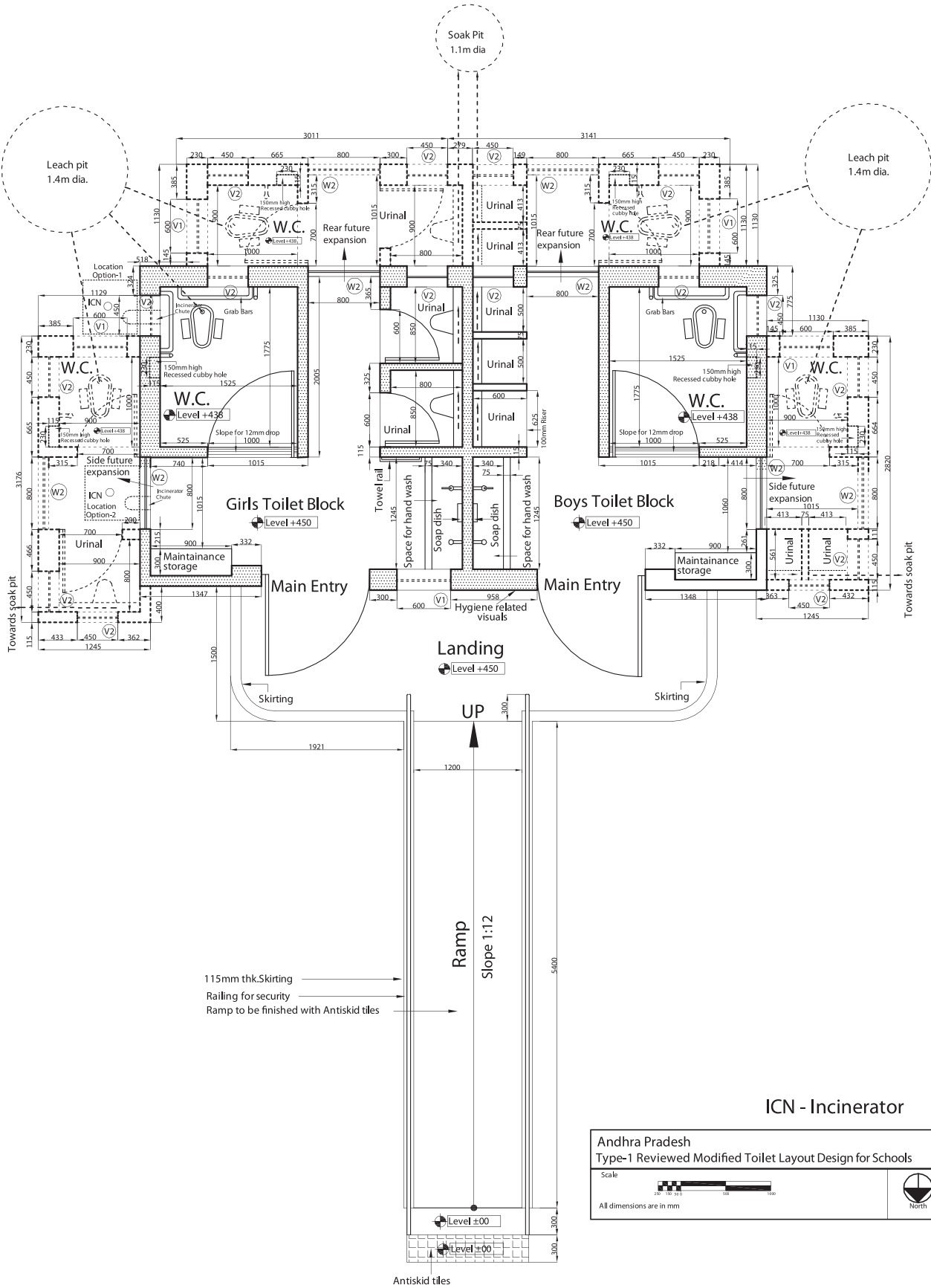

Good Design - Gujarat

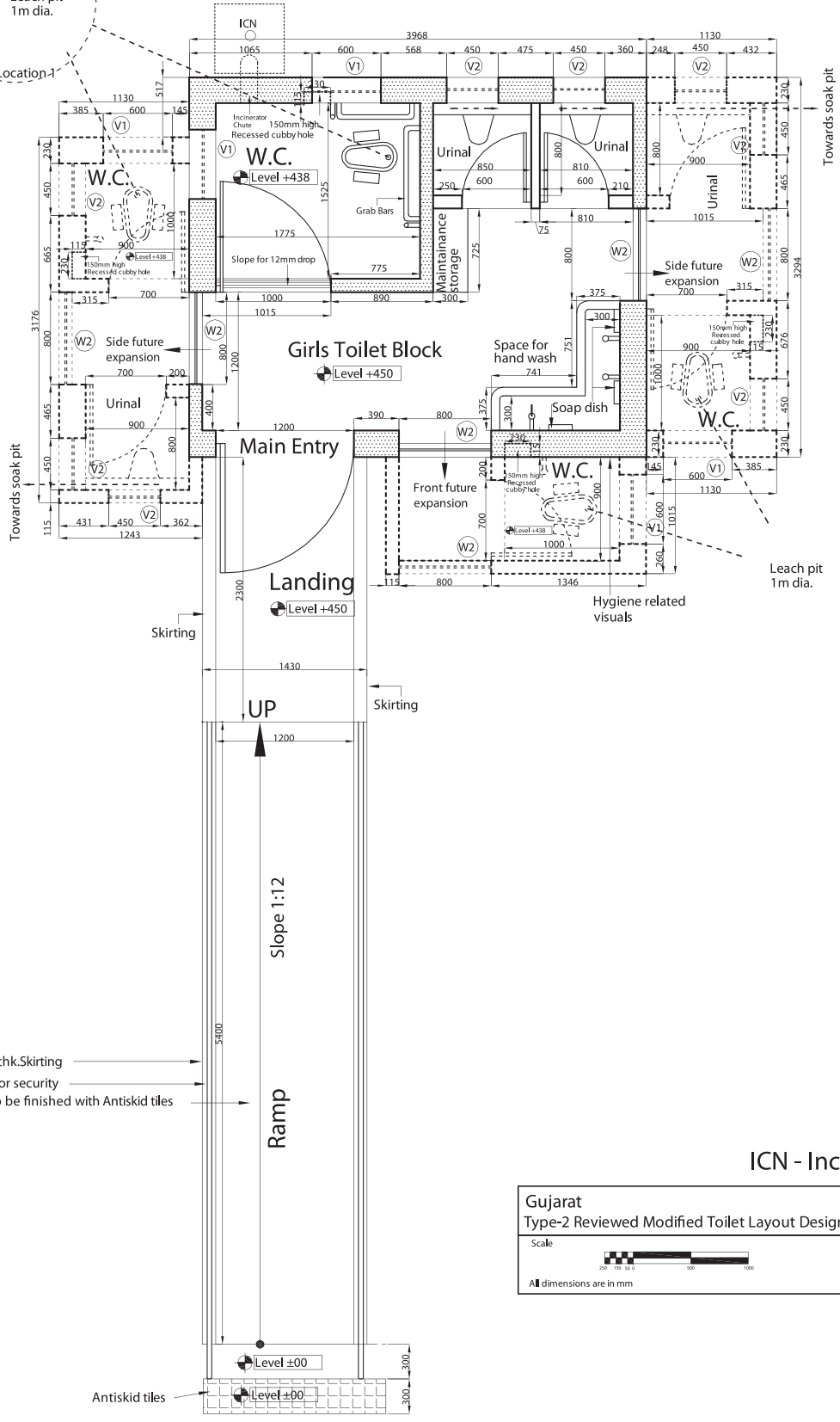
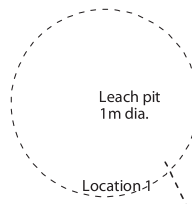

- 115mm thk. Skirting
- Railing for security
- Ramp to be finished with Antiskid tiles

ICN - Incinerator

<p>Gujarat Type-2 Reviewed Modified Toilet Layout Design for Schools</p>	
<p>Scale</p>	<p>North</p>
<p>⚠ All dimensions are in mm</p>	

Good Design - Jharkhand

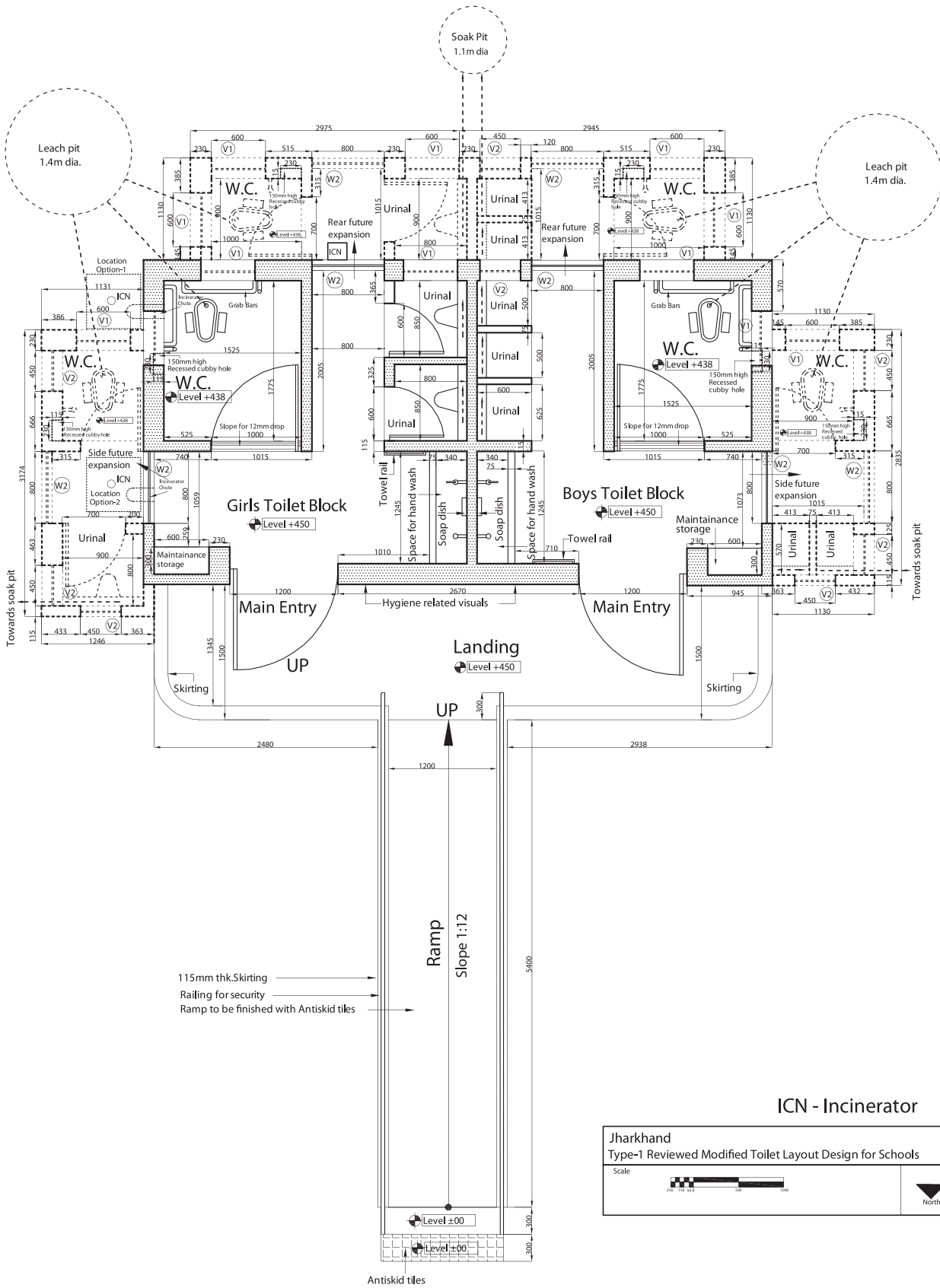

Good Design - Madhya Pradesh

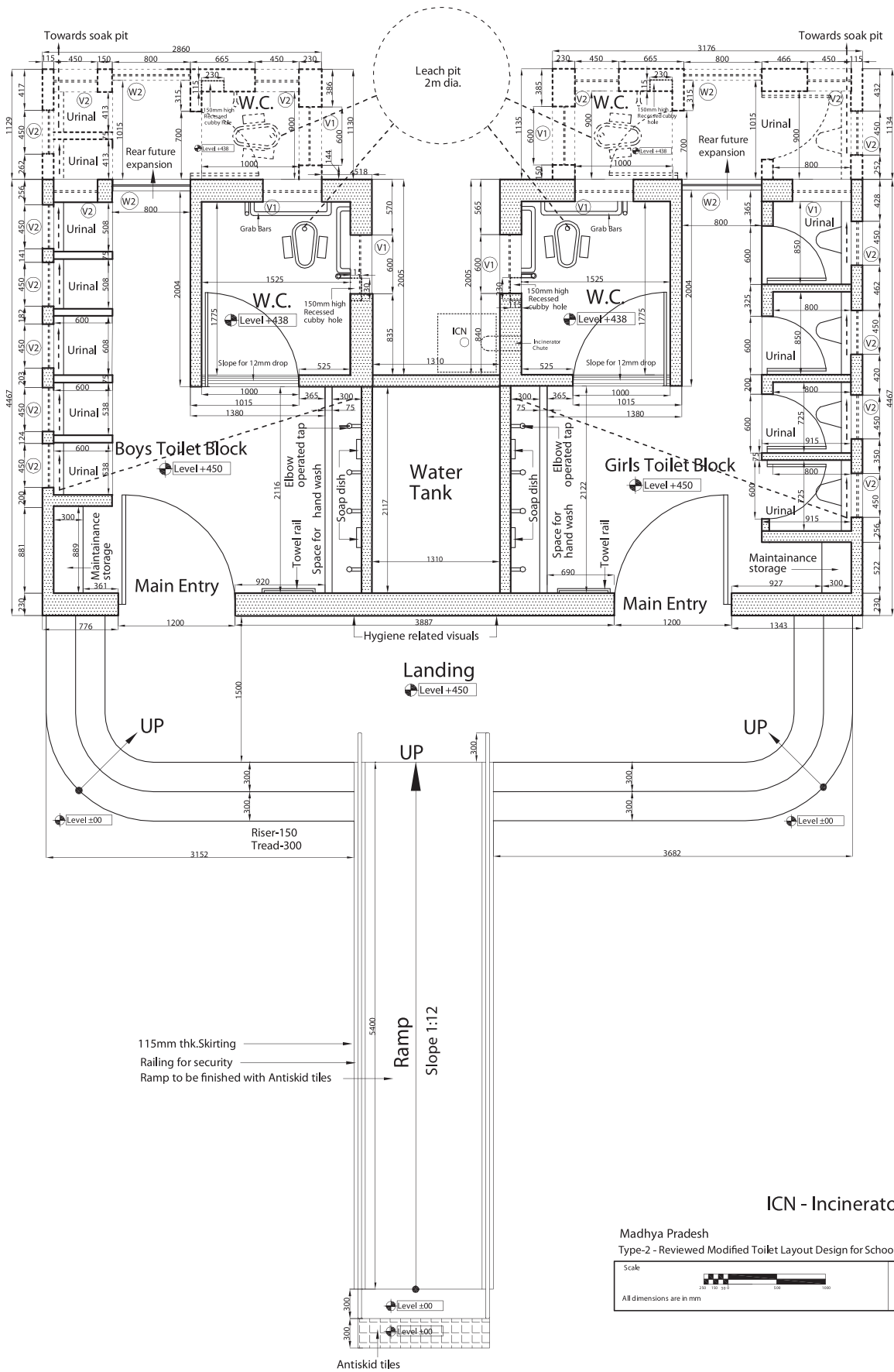

ICN - Incinerator

Madhya Pradesh
Type-2 - Reviewed Modified Toilet Layout Design for Schools

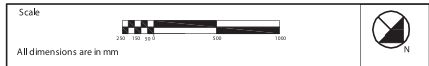

Good Design - Orissa

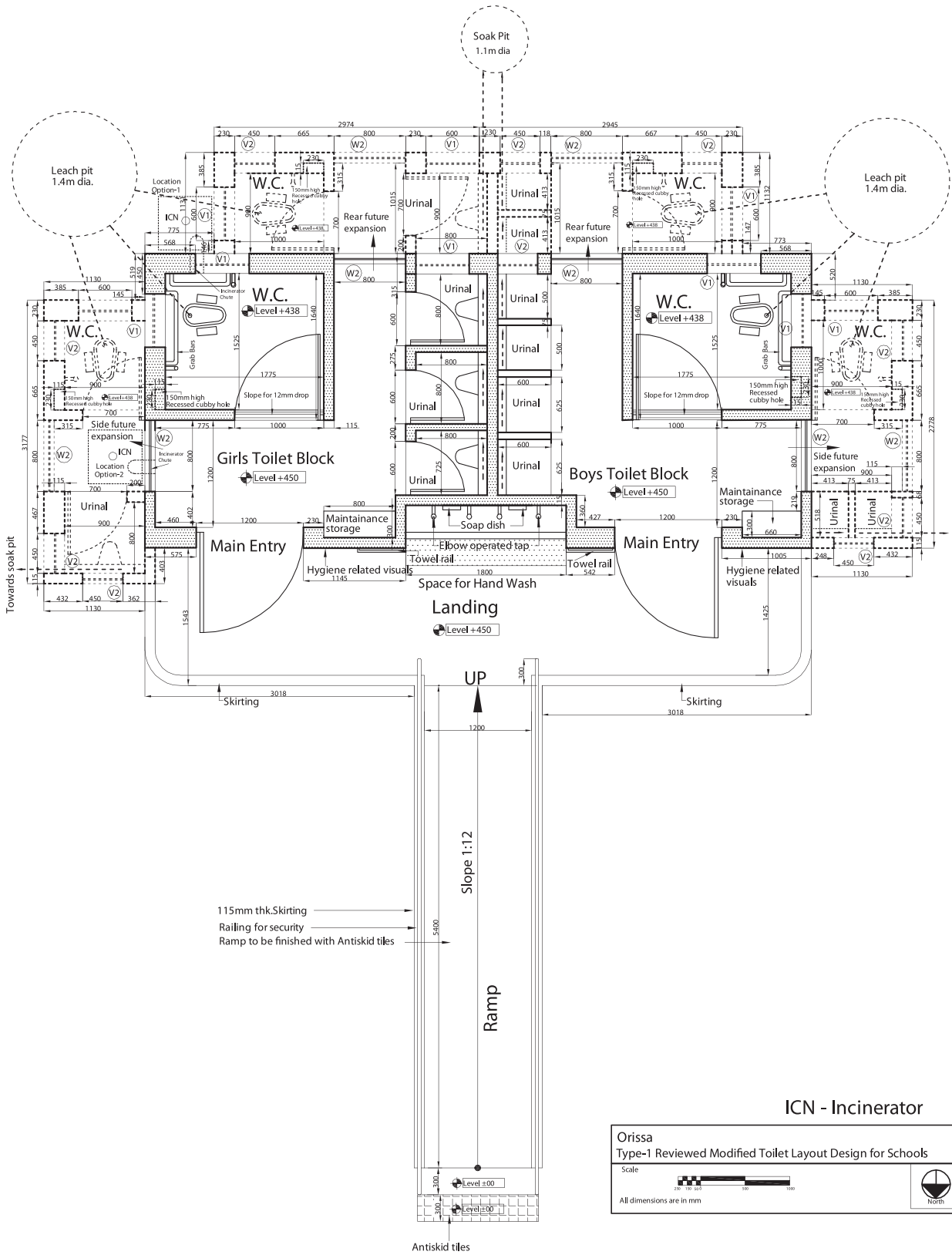

ICN - Incinerator

Orissa
 Type-1 Reviewed Modified Toilet Layout Design for Schools

Scale

All dimensions are in mm

unite for children

United Nations Children's Fund
73, Lodi Estate
New Delhi, INDIA

www.unicef.org

Government of India

Ministry of Rural Development
Department of Drinking Water Supply
Rajiv Gandhi National Drinking Water Mission
9th floor, Paryavaran Bhawan, CGO Complex,
Lodi Road, New Delhi - 110003

website:www.ddws.gov.in

